

65 YEARS

100%
MADE IN
NZ



Classic Renovator

Operation & Parts Manual



Renovator Classic Contents

| | Page |
|---|-------|
| Introduction | 2 |
| Acquisition & Warranty | 2 |
| Disclaimer | 2 |
| Description of Machine | |
| Working Principle..... | 3 |
| Specification | |
| Dimensions & Capacities | 5 |
| SAFETY - General | |
| Safety Symbols on Machine | 6 |
| Operator Safety..... | 7 |
| Be Prepared for Emergencies..... | 7 |
| Appropriate Dress | 8 |
| Transport This Machine Safely | 8 |
| Handle Agricultural Chemicals Safely..... | 9 |
| Avoid High Pressure Fluids..... | 9 |
| Safe Work Practices | 9 |
| Practise Safe Maintenance | 10 |
| SAFETY - Machine Specific | |
| Hazard Points | 11 |
| Safety Decals & Safety Guards..... | 13 |
| Transport | |
| Operation | 14 |
| | 15 |
| Sowing Chart | 17 |
| Basic Calibration Procedure | |
| Gearbox Setting Lever | 18 |
| Setting Seeder Shutter Slides..... | 18 |
| Bottom Flap Settings..... | 18 |
| Seed Calibration | 19 |
| Hand Crank Turns for Seed Rate Calculation..... | 20 |
| Use of Seed Rate Calculator..... | 21 |
| Calibration Deviations | 22 |
| Sowing of Fine Seeds..... | 23 |
| Sowing Small Seeds | 24 |
| Sowing Peas | 24 |
| (Optional) Jackal Hectaremeter Settings | 25 |
| Calibration Notes..... | 27 |
| Maintenance & Care | |
| General | 28 |
| Lubrication Instructions | 29 |
| Maintenance Schedule | 30 |
| Storage | 32 |
| Troubleshooting..... | 33 |
| Maintenance Notes | 36 |
| Parts List | |
| Base Machine | 37 |
| Optional Extras | 63-71 |

Introduction

Acquisition & Warranty

On delivery of your new Duncan Renovator Classic please check that the machine is not damaged. In cases of shipping damage, please ask your dealer to arrange for the appropriate claim to be lodged immediately. Assemble any parts supplied loose and inspect your machine with the aid of this manual to familiarise yourself with its features. If you have any queries ask your dealer straight away. The machine is covered by our 12 month warranty on faulty parts, subject to normal use.



Record below the serial number of your machine and keep it in a secure place to help trace the machine and assist us when you order parts.

| |
|-----------------------------|
| Model: |
| Serial No: |
| Owner: |
| |
| |
| Delivery Date: |
| Dealer: |
| |
| |

| |
|--|
| This Document contains the Original Operating Instructions for this machine and are verified by the Manufacturer, Signed:..... Product Development Manager |
|--|

The Owner's Manual

Your new Duncan Renovator Classic will give long and efficient service if given normal care and operated properly.

This owner's manual is provided so that you can become thoroughly familiar with the design of the machine and to furnish information on correct operation, adjustment and maintenance. **Only persons well acquainted with these guidelines should be allowed to use the equipment.**

A separate illustrated parts section has been provided so that if any parts are required your dealer will be able to supply them by reference to part numbers.

The manual is considered as part of your machine and must remain with the machine when it is sold.

Right and left hand references in this manual are determined by standing behind the machine and facing in the direction of travel.

| |
|--|
| Disclaimer Every effort has been made to ensure that the information in this manual was accurate and up to date at the time of going to press. Clough Agriculture reserves the right to make subsequent changes to the machine, where necessary, without notification. The Company will not be responsible for any damage or consequential loss arising out of misinterpretation or failure to follow recommended procedures. Nor will it be liable for any damage caused by or arising out of modification or misuse of its product. The owner has a responsibility to protect himself and others by observing all safety information and by ensuring all operators are well acquainted with the safety information, trained in the correct use of the machine and applying safe work practices. |
|--|



Description of Machine

The Duncan 'Renovator Classic' is a Coil Tine Tee-boot drill. The box is mounted on a robust frame accommodating large diameter tyres for the arable situation. The ground engaging components are controlled by a hydraulic ram and rocker arm system, giving ample control on ground pressure, good transport clearance and contour following ability. Sowing depth is controlled by adjusting the hydraulic ram as required. The quality European type peg roller seeder system handles all seeds from turnip and rape through to peas and maize. The seeders are driven from the groundwheels via a jockey wheel system and variable speed gearbox. For transport the drive is easily disconnected by raising the drill to its transport height.

Working Principle

The gearbox, pegged seed rollers and seeder flaps are set to give the desired seed rate. The coil tine and tee-boot, create the seed bed. Seed flows down the flexible tubes between seeder and tee-boot units, and drops into the prepared seed bed.

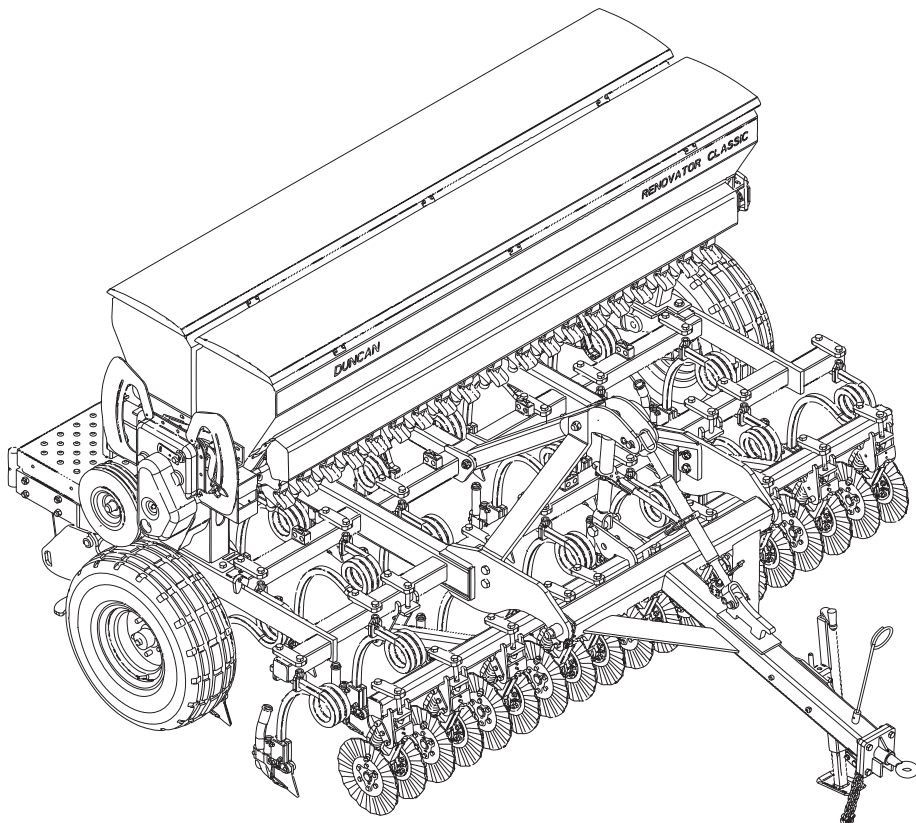

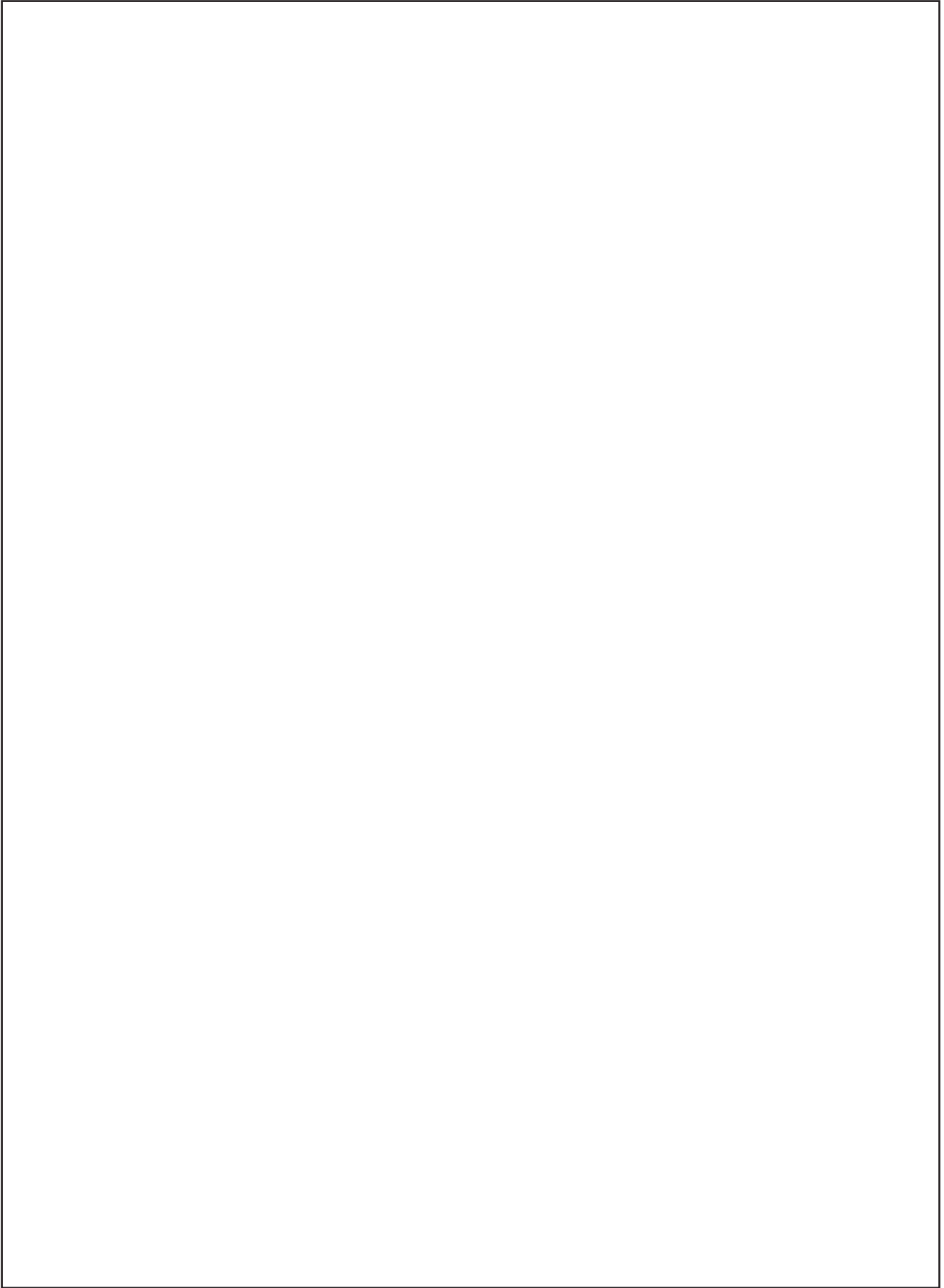

Dimensions & Capacities

| Dimensions & Capacities | |
|------------------------------------|--|
| Width (over wheels /mm) | 3026 |
| Height (Groundwheels up /mm) | 1700 |
| Height (Groundwheels down /mm) | 2035 |
| Overall Length (mm) | 3512 |
| Weight inc. disc openers (unladen) | 1610 |
| Tyre Size | 10/80/12 |
| Recommended Tyre Pressure | 4 Bar (58psi) |
| Maximum speed (km/hr) | 40 km/hr |
| Jockey Tyre Size | 410/350 x 6 x 4 ply |
| Jockey Tyre Pressure* | 3.44 Bar (50 psi) - TYRE IS FILLED WITH ANTI-PUNCTURE SEALANT* |
| Row Spacing | 147.5 |
| Effective Sowing Width | 2802.5 |
| Box Capacity (litres per box) | 350 |
| Maximum Tractor HP Rating | 180 |

**Pressure gauges may be damaged if they are not filtered*

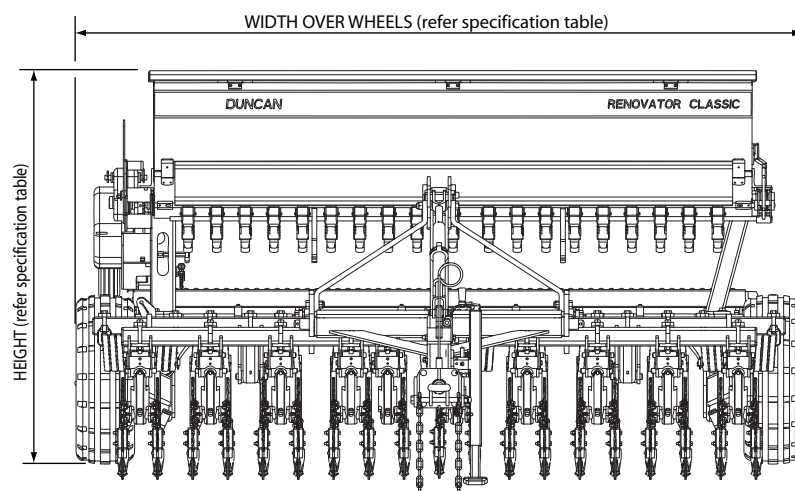
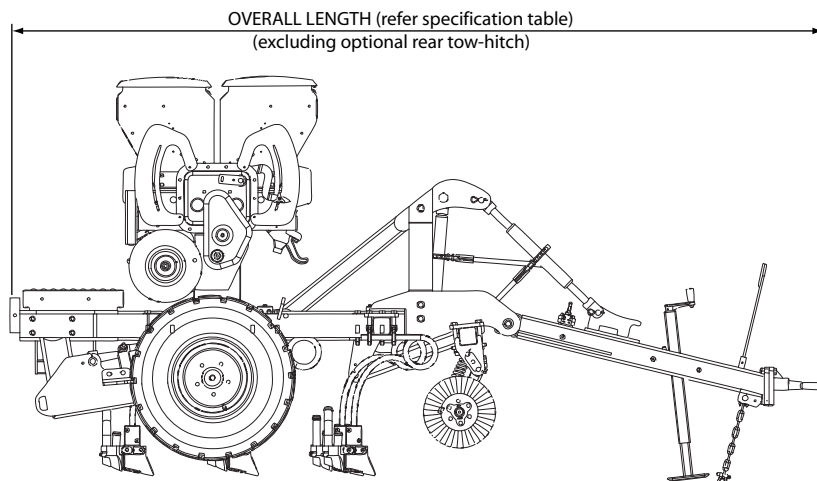

! ATTENTION

On the machine important safety information is indicated by these symbols.

These highlight general safety aspects in regard to the machine rather than specific hazards.



Do not ride or allow passengers on the machine.

Under no circumstances are passengers to be permitted on the machine while it is in operation or being transported. Any footboards and/or footsteps are provided solely for the purpose of preparing the machine for use.



Keep clothing and body extremities well clear of pinch points while the machine is operating (seeding or calibrating). Keep well clear of moving parts at all times.

These signs typically occur wherever trapping points exist. These include drive chains, sprockets, shafts, wheels, discs, pivot points, etc. Guards are provided with the machine for safety reasons (where practical without compromising machine performance). Ensure these are always fitted during operation.



Always exercise extreme caution in the vicinity of sharp edges and points.

Where possible guards are provided with the machine for safety reasons (where practical without compromising machine performance). Ensure these are always fitted during operation.



Footboards, footsteps, drawbars and other machine surfaces may be slippery when wet.

Apply extra caution in wet conditions and in the early morning when surfaces are wet.

KEEP CLEAR

Keep Clear. (It is dangerous to be in this area when the machine is operating.)

SAFETY - General

N.B. Throughout this manual important safety information is indicated by these symbols in the margin:



A prohibition should be observed under all circumstances.



A warning indicates a hazard that could cause death or injury if the warning is ignored.



A caution indicates a hazard that may cause damage to property if the caution is ignored.

This section of the manual offers general guidelines for the safe operation of machinery. It does not replace local safety regulations. These guidelines were current at the time of publication, but may be superseded by later regulations.

Clough Agriculture has made every effort to highlight all risks to personnel or property. Owners and operators have a responsibility to exercise care and safe work practices at all times in the vicinity of the machine.

Owners are advised to keep up to date on safety issues and to communicate these to all users of the machine.

Contact the Occupational Safety and Health Service (OSH) for further information about general safety aspects. If you have safety concerns specifically related to this machine, contact your dealer immediately.

Operator Safety

Read this manual carefully before operating new equipment. Learn how to use this machine safely. Be thoroughly familiar with the controls and the proper use of the equipment before using it.



Take careful note of all safety instructions both in this manual and on the machine itself. Failure to comply with instructions could result in personal injury and/or damage to the machine.

Replace missing or damaged safety signs on the machine and ensure that these remain clearly visible.

It is the owner's responsibility to ensure that anyone who operates, adjusts, lubricates, maintains, cleans or uses the machine in any way has had suitable instruction and is familiar with the information in this manual (particularly with regard to safety aspects).

Operators and other users of the machine should be aware of potential hazards and operating limitations.



Be Prepared for Emergencies

Keep a first aid kit and fire extinguisher handy.

Keep emergency numbers for doctors, ambulance, hospital and fire department near your telephone.



SAFETY - General (Continued)



Appropriate Dress

Wear close fitting clothing and avoid rings or other forms of jewellery which could become caught in the machinery.

People with long hair must have it securely fixed and confined close to the head.

Refer to local safety standards for protective clothing and recommended safety equipment.



Transport This Machine Safely

Ensure that all linkage pins and security clips are fitted correctly. With trailing machines tow with the drawbar only, as this is the only safe towing point on the machine.

Always check that bystanders (especially children) are well clear (front and rear) before starting and moving the tractor and the machine.

Plan safe routes of travel, and be aware of power lines and other roadside hazards. Take particular care when towing implements on hillsides.

Do not ride or allow passengers on the machine.

This machine is not designed to carry passengers, and no riders are permitted.

Road transport

On public roads,

- A speed of 30km/h must not be exceeded.
- Do not operate during the hours of darkness unless standard lights are fitted and clearly visible. (This also applies when visibility is limited, e.g., in foggy conditions.)

See the guidelines in the *Vehicle Dimensions and Mass Rule*, issued by the Land & Transport Safety Authority.

Avoid tip-overs

Avoid holes, ditches and obstructions which may cause the machine to tip over, especially on hillsides. Never drive near the edge of a gully or steep embankment - it might cave in. Slow down for hillsides, rough ground and sharp turns.



SAFETY - General (Continued)

Handle Agricultural Chemicals Safely

All farm chemicals should be stored, used, handled and disposed of safely and in accordance with the supplier's/manufacturer's recommendations.



Read the product label before using, noting any warnings or special cautions, including any protective clothing or equipment that may be required, ie. respirator.

Do not eat or smoke while handling sprays, fertilisers, coated seeds, etc. Afterwards, always wash your hands and face before you eat, drink, smoke, or use the toilet.



Store sprays, fertilisers, coated seeds, etc. out of reach of children and pets, and away from food and animal feeds.

Any symptoms of illness during or after using chemicals should be treated according to the supplier's/manufacturer's recommendations. If severe, **call a physician or get the patient to hospital immediately.** Keep the container and/or label for reference.

Avoid High Pressure Fluids

Avoid any contact with fluids leaking under pressure, because the fluids can penetrate the skin surface.



Any fluid which penetrates the skin, will need to be **removed immediately by a medical expert.** Seek specialist advice on this type of injury.

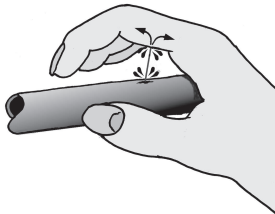

Relieve the pressure before disconnecting any hydraulic or other lines. Make all repairs and tighten all fittings before re-connection to pressurised fluid.

Keep your hands and body away from any pinholes or high pressure jets. Search for leaks with a piece of cardboard instead of using your hand directly.

Safe Work Practices

All farm machinery is potentially dangerous and should be treated with caution and respect.



Before starting the machine, ensure that all controls are placed in neutral and that bystanders are well clear. Check that the guards have been securely fitted and that any adjustments have been made correctly.

Where possible, disconnect or isolate the drive mechanism to the implement. Lower the machine onto the ground when not in use.

SAFETY - General (Continued)



Practise Safe Maintenance

Keep the machine in safe working condition. Routine maintenance and regular servicing will help reduce risks and prolong the life of the machine.

General Maintenance

Accidents occur most frequently during servicing and repair. The following general rules must be followed when maintaining or working with machinery:

- All operating and maintenance manuals must be read before and referred to while using or servicing any piece of equipment.
- Turn off all machinery power sources and isolate the machine before making adjustments, doing lubrication, repairs or any other maintenance on the machine.
- Ensure that the machine hydraulics are disconnected from the power source.
- Wear gloves when handling components with cutting edges, such as any ground cutting components.
- Beware of hazards created by springs under tension or compression when dismantling or maintaining the machine.
- It is recommended that you clean the machine with a water blaster or similar apparatus before commencing maintenance.

Make Sure the Machine is Well Supported

When machinery is fitted with hydraulics, do not rely on the hydraulics to support the machine. During maintenance or while making adjustments under the machine, always lock the hydraulics and support the machine securely. Place blocks or other stable supports under elevated parts before working on these.



Electrical Maintenance

Disconnect the electrical supply from the tractor before doing any electrical maintenance.



Welding

With electronic equipment in modern tractors it is advisable to disconnect the machine from the tractor, or at least disconnect the alternator and battery before attempting any welding.



Use Only Genuine Spare Parts

Unauthorised modifications or non-genuine spare parts may be hazardous and impair the safe operation and working life of the machine.

Excess lubricants must be disposed of safely so as not to become a hazard.

SAFETY - Machine Specific

This section of the manual gives specific guidelines for the safe operation of the Renovator Classic.

These guidelines were current at the time of publication, but may be superseded by later circumstances. They do not necessarily cover every possible hazard and must be read in conjunction with the **SAFETY - General** section (Page 4 - 8).

Hazard Points on the Renovator Classic

The lists below are not all-inclusive and serve only to highlight the more obvious areas of risk.



The decals attached to the machine are a general reminder that there are hazardous areas on the machine, rather than specifically highlighting all possible hazards.

For decal locations on machine, refer Page 11.



No Ride

Passengers are not permitted anywhere on the machine.



Pinch Points/Moving Parts

Hazardous areas include:

- Drive chains.
- Sprockets between the drive wheel, the transfer shaft and the gearbox (RH side).
- Sprockets between the gearbox and the box shafts (RH side).
- Agitator drive units (LH side).
- Agitator shaft inside the boxes.
- Seeder units, box shaft and shaft connectors.
- Wheel legs and main frame assemblies
- Between discs and other sub-assembly parts (where fitted).
- Press wheel assemblies (where fitted).



**Slippery
When
Wet**

Slippery When Wet

Hazardous areas include:

- Footboards and footstep.
- All smooth surfaces on the frame structure.

KEEP CLEAR

Keep Clear

Hazardous areas include:

- Between the tractor and Renovator Classic.
- Immediately adjacent to the Renovator Classic side.

SAFETY - Machine Specific (Continued)



Hazard Points on the Renovator Classic (Continued)

Pedestal Chain Guards

To prevent hands, etc. getting caught in drive chains, guards are provided to cover sprockets, chain and chain tensioners mounted about the drive pedestal (RHS). These guards must be fitted while using the machine.

Warning: Access to pinch points is still possible from underneath the guard.

For guard locations on machine, refer Page 13.

Calibrating

Be particularly careful when calibrating the seeding rate. At this time, the calibration trays have been removed and are no longer covering the rotating seeder units. See **Pinch Points/ Moving Parts** (Page 11) for hazardous areas.

Transport

The two wheels located at the sides of the machine are for the purpose of controlling sowing depth. These are also used to support the machine weight during transport (while linked to the tractor).



Important - Refer to safety cautions in the **Transport** section, page 14 of the manual. Ensure that all linkage pins and security clips are fitted correctly.

Maintenance

Refer Page 28 for reference to the **Maintenance and Care** section of the manual.

Lubrication

Refer Page 29 for reference to the **Maintenance and Care** section of the manual.

SAFETY - Machine Specific (Continued)

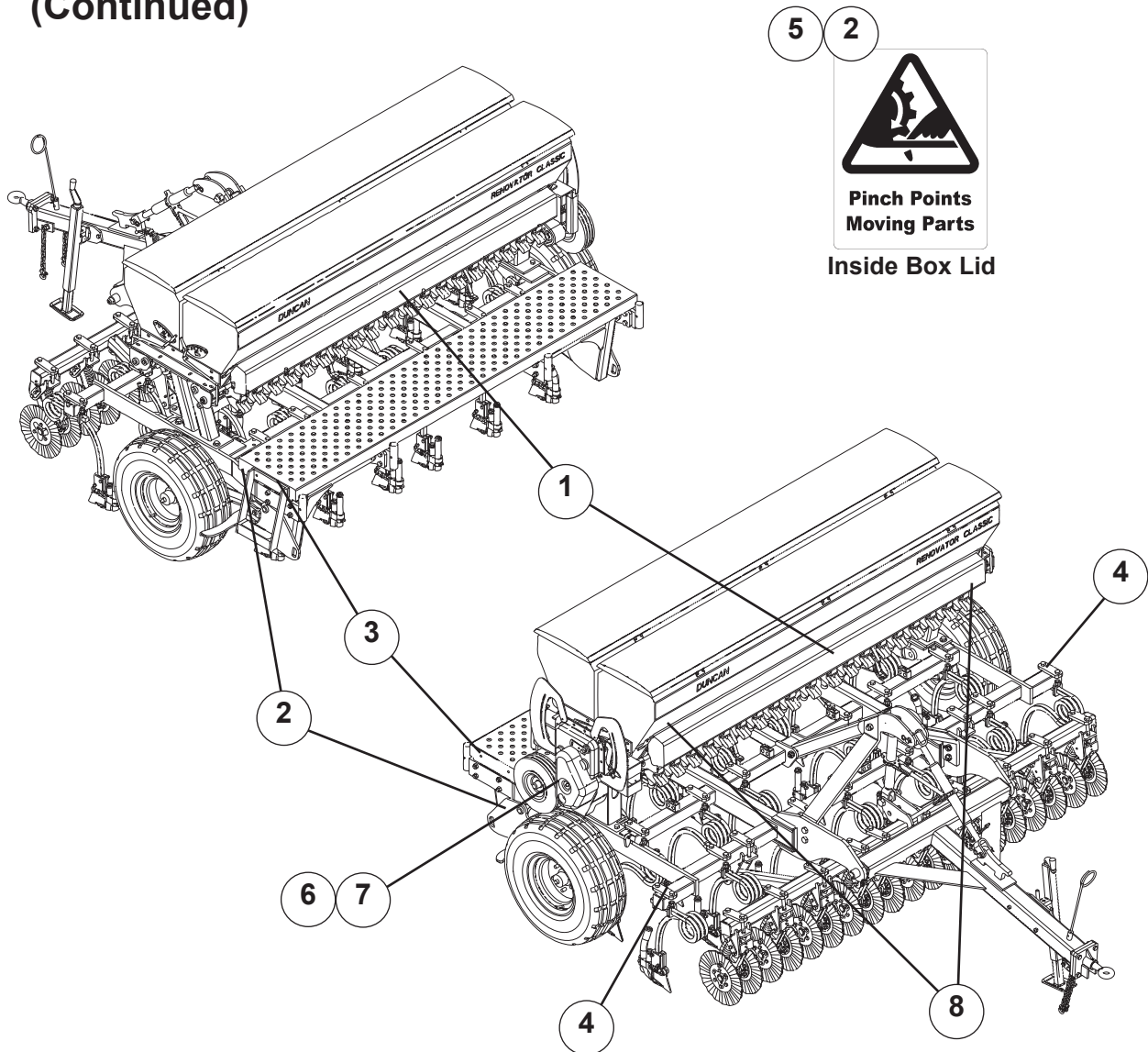

| Item | Decal/Guard | Pt. No. | Qty |
|------|----------------------------|---------|-----|
| 1 | 'No Ride' | 43900 | 3 |
| 2 | 'Pinch Point/Moving Parts' | 43901 | 5 |
| 3 | 'Slippery When Wet' | 43902 | 2 |
| 4 | 'Keep Clear' | 43904 | 2 |
| 5 | Arrows (Inside Box Lid) | 43905 | 4 |
| 6 | Pedestal Drive Guard | 25995 | 1 |
| 7 | Jockey Drive Swing Guard | 25745 | 1 |
| 8 | '30 km/hr' | 43911 | 2 |

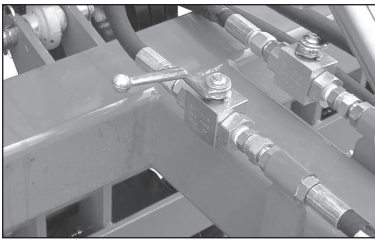

Fig 1



Transport

1 Raise the drill into the transport position and hold at the full extent of the rams for a few seconds to allow cylinders to rephase/equalise.

2 **Important** - To avoid machine damage due to drill lowering during transport, always close the hydraulic valve on the drawbar. Move the handle to a position at 90° to the hydraulic line as shown in Fig 1. This applies to the drawbar and disc opener hydraulic valves where fitted.

3 Locate jack stand in transport position, if fitted. Refer Fig 2.

4 Ensure lighting and oversize warning requirements meet recommendations published by the local Land Transport Authority or equivalent.

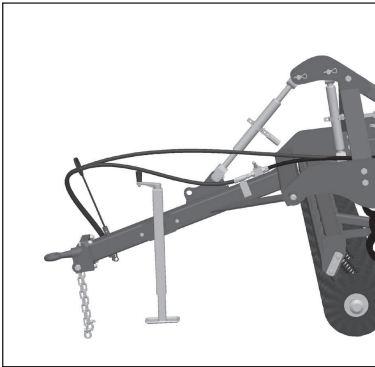

Fig 2



5 **Maximum towing speed 30 km/hr.** For countries other than New Zealand greater speed restrictions may apply, please refer to your local transport authority.

Ensure towing vehicle requirements are adequate for the towed vehicle e.g. mass, brakes. Refer to recommendations published by the local Land Transport Authority or equivalent.

Braking when towing can cause the load to jackknife. Use extra care when towing in adverse conditions such as mud, inclines and sharp bends.

Lower towing speeds are recommended on farm roads/tracks and where one wheel is on or over a road verge.



Fig 3



6 **Attach safety chains to tractor.** Refer Fig 3. Safety chains must be crossed over underneath the coupling and attached to the towing vehicle. The attachment points must be as close as practical to the towing coupling and one each side. The towbar on the towing vehicle must be rated for the towed mass. **Do not remove or replace the safety chains provided with any other than those specified in the parts manual.**

Note: The safety chains are provided with sufficient length to cater for all towing vehicles. Safety chains must be shortened by cutting off excess length so that if the coupling fails the drawbar will not hit the ground.

7 If the machine is fitted with row markers or other vertical extensions, check clearance under power lines en route.

8 **Important** - For greater disc opener ground clearance, adjust the ram or turnbuckle on the disc opener unit so they are at maximum height, and/or extend the drawbar ram or turnbuckle to level the machine chassis.



Operation

General Operation Guidelines

- 1 Use a sufficiently powerful tractor which is heavy enough to tow the drill safely.
- 2 Operate the drill at a speed of 6-12 km/hr (4-8 mph).
In stoney and uneven ground conditions a lower speed is more appropriate
- 3 Check that the drill is level during calibration and while seeding.
- 4 Check tyre pressure before seeding. Refer page 3.
- 5 Double check seed rates before seeding.
- 6 Raise the drill out of the ground when making any turns.
- 7 Raise the drill out of the ground before backing up.
- 8 Stretched sagging hoses disrupt seed flow. Slight tension may be restored by carefully shortening the affected hose; remove from the tube at ground level and cut accordingly.
Care must be taken not to shorten too much as the tension will pull the hose from the ground tube or damage the plastic metering funnel.
- 9 After prolonged storage, check to see that all drive mechanisms and hydraulic equipment are functioning correctly. Check that the seed tubes are not perished or blocked.

Sowing Speed

Typical travel speeds when sowing range from 6-12 km/hr in good conditions. In stoney and uneven ground conditions a lower speed is recommended to minimise rapid part deterioration. Sowing too fast can result in:

- 1 Poor contour following and uneven sowing depth.
- 2 Impact damage to:
 - a Ground engaging components.
 - b Bearings, housings & axles.
 - c Fasteners & structural components.
- 3 More extreme conditions will result in greater vibration and uneven seed flow at low seeding rates.

Sowing Depth Control

The sowing depth is dependent on:

- 1 The wheel height in relation to the chassis
- 2 Tyre pressure
- 3 Ground condition i.e. hard or soft

The wheel height in relation to the chassis is controlled using the threaded depth adjustment collar (1) Refer Fig 4.

Caution: Do not over extend the thread depth adjustment collar. Additional collars may be required.

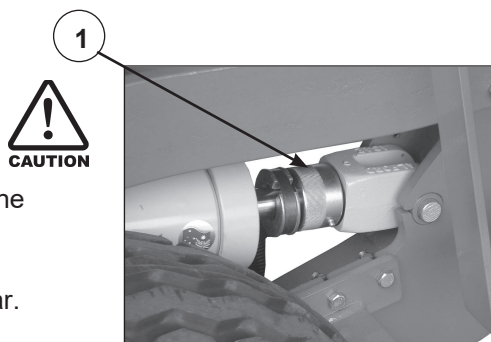

Fig 4

Level Drill

Use the drawbar turnbuckle or ram to tilt the drill so it is sitting level. An adjustment may be required after a short period of use because the paint wears off the discs and the discs sharpen which in turn improves the penetration abilities.

Transport Position

When in the transport position the hydraulic cylinders are fully extended. In this position the cylinders fully equalise by allowing oil to bypass the master cylinder piston. It is recommended to raise the drill into the transport position when turning at headlands or regularly to counteract the effects of oil leakage past the piston and ensure cylinder rods are equally extended and minimise variations in sowing depth.

Coulter Penetration Depth

To create the ideal seed bed the disc opener coulter should cut approximately 20mm below the inverted tee point. In hard and dry conditions this may not be achievable, and better machine/sowing performance may be achieved without using the disc openers. An indication of this will be the machine bouncing which will result in uneven sowing depth.

Coulters will give better penetration ability as they sharpen with use.

Renovator Classic Sowing Chart

High & Low Ratio - Row Spacing 147.5

Table 3

| Test Seed Type/ Thousand Seed Wgt., TSW*(gm) | Gear Ratio* | Shutter Slide* | Bottom Flap* | Metering Wheel* | Seed Rate (kg/ha) | | | | | | | | | | Hints |
|--|--------------------------|----------------|--------------|-----------------|-------------------|-------|--------|--------|--------|--------|--------|--------|--------|--------|------------------|
| | Gearbox Setting Position | | | | | | | | | | | | | | |
| | H/L | Position | Type | 15 | 20 | 30 | 40 | 50 | 60 | 70 | 80 | 90 | 100 | | |
| Wheat (41.2) | H | 3/4 | 3 | N | | | | | 102.14 | 128.78 | 152.36 | 180.03 | 208.25 | 234.35 | |
| Oats (37.2) | H | Full | 3 | N | | | | | 98.98 | 122.97 | 146.37 | 171.74 | 196.99 | 219.56 | |
| Barley (45.7) | H | Full | 3 | N | | | | | 117.66 | 144.97 | 176.33 | 205.4 | 236.51 | 266.22 | |
| Ryecorn (25.8) | H | 3/4 | 3 | N | | | | | 118.96 | 148.03 | 178.5 | 207.32 | 240.85 | 270.94 | |
| White Peas (302) | H | 3/4 | 3 | N | | | 111.97 | 161.93 | 213.44 | 246.59 | 305.11 | 358.66 | 397.42 | 457.22 | Agitator Stopped |
| Green Peas (240) | H | 3/4 | 3 | N | | | 77.62 | 116.89 | 156.06 | 192.65 | 230.78 | 272.72 | 316.2 | 355.73 | |
| Peren. Grass (2.27) | H | Full | 3 | N | 6.53 | 13.73 | 27.41 | 40.90 | 53.86 | 67.23 | 81.51 | | | | |
| Annual Grass (4.4) | H | Full | 3 | N | 8.06 | 16.32 | 31.75 | 46.31 | 60.67 | 76.68 | | | | | |
| Pasture Mix* (-) | H | Full | 3 | N | | 13.92 | 27.59 | 41.31 | 54.42 | 67.38 | 81.65 | | | | |
| Lucerne (3.17) | H | 3/4 | 1 | F | | | 9.27 | 13.82 | 17.97 | 22.43 | 26.38 | | | | Agitator Stopped |
| Turnip (2.17) | L | 3/4 | 1 | F | 0.96 | 1.76 | 3.21 | 4.63 | 6.0 | | | | | | Agitator Stopped |
| Kale (3.20) | L | 3/4 | 1 | F | | 1.69 | 3.21 | 4.66 | 6.02 | | | | | | Agitator Stopped |
| Swedes (3.25) | L | 3/4 | 1 | F | 0.94 | 1.65 | | | | | | | | | Agitator Stopped |
| Rape (3.50) | L | 3/4 | 1 | F | | 1.62 | 3.0 | 4.44 | 5.78 | | | | | | Agitator Stopped |
| White Clover (1.11) | L | 3/4 | 1 | F | 0.82 | 1.57 | 3.06 | 4.47 | 5.65 | | | | | | Agitator Stopped |
| Red Clover (2.23) | L | 3/4 | 1 | F | | 1.90 | 3.56 | 5.05 | 6.66 | 8.17 | 9.75 | | | | Agitator Stopped |
| Super Phosphate | H | Full | 3 | N | | | 91.51 | 140.12 | 185.26 | 235.37 | 286.62 | 344.51 | 397.16 | 456.96 | |
| DAP Granules | H | Full | 3 | N | | | | | 174.04 | 214.2 | 256.66 | 301.67 | 346.42 | 382.88 | |
| Super Phosphate | L | Full | 3 | N | | | | 53.7 | 71.0 | 90.24 | 109.84 | 132.03 | 152.25 | 182.99 | |
| DAP Granules | L | Full | 3 | N | | | | | | | | 115.64 | 132.81 | 146.77 | |

Gear Ratio*: H, High = 21T on Transfer Shaft,
13T on Gearbox Input Shaft.
L, Low = 13T on Transfer Shaft,
21T on Gearbox Input Shaft.

Shutter Slide*: For Grain, changing the Shutter Slide from 3/4 to Full gives
10% to 15% more flow.

Pasture Mix*: Test Mixture = 72% Perennial Grass, 8% White Clover,
8% Cocksfoot, 8% Concord, 4% Red Clover

Bottom Flap*: The values shown were the optimum test settings,
decreasing the gap may cause seed damage, too large a gap will give
intermittent flow rates. (Flaps are spring loaded to cope with small
variations in seed/granule size).

Metering Wheel*: N = Normal Metering Wheel
F = Fine Seed Metering Wheel

TSW*: $\frac{\text{TSW(gm)} \times \text{Desired Plants/m}^2}{\text{Germination \%}} = \text{Sowing Rate (Kg/Ha)}$

Notes

1. Where a small seeds box is used,
multiply the above seed rates by **0.80** to
account for the different gearing ratio.
2. Seed rates shown are approximate
only for the respective gearbox setting.
It is recommended that the calibration
procedure is always used. Refer to
page 18.

Basic Calibration Procedure

Gearbox Setting Lever

To set the seed rate at the gearbox, slacken the star knob (1) by turning counter-clockwise and push from below into the position indicated in the Sowing Chart. Retighten the star knob firmly (Fig 6).

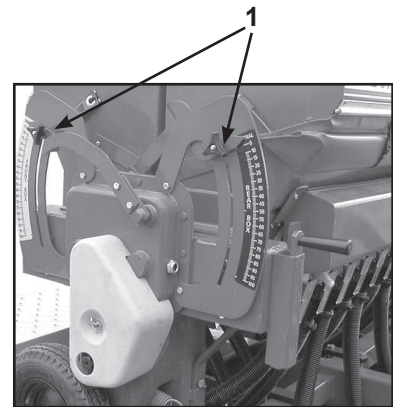

Fig 6

Important

The settings shown in the Sowing Charts (kg/ha) can only serve as reference values. Deviations may occur caused by differences in the size, shape, density of the grain and by the dressing agent. **Therefore prior to any sowing, always carry out calibration trials to accurately determine the actual seed rate.**

Using the stepless variable speed gearbox, the speed of the metering shaft and thus the seed rate is set steplessly. The higher the figure indicated on the scale by the setting lever the greater the seed rate (Fig 6).

Selecting the Gear Ratio

The Seed Drill is designed with a two speed (high and low) gear ratio arrangement where the moving of the chain from a 21 x 13 teeth ratio to a 13 x 21 teeth ratio changes the output from high to low (Fig 7). The selection and method for changing the ratio is detailed under Speed Setting Page 23.

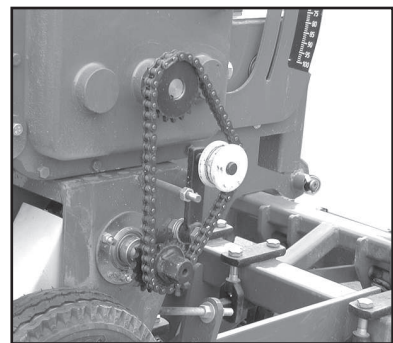

Fig 7

Setting Seeder Shutter Slides

The varying flow properties of seeds require different shutter slide positions which may be found in the Sowing Chart for the individual type of seed. This corresponds to one of the three settings in Fig 8.

| Fig 8/A | Fig 8/B | Fig 8/C |
|---------|----------|------------|
| Closed | 3/4 Open | Fully Open |

Table 4

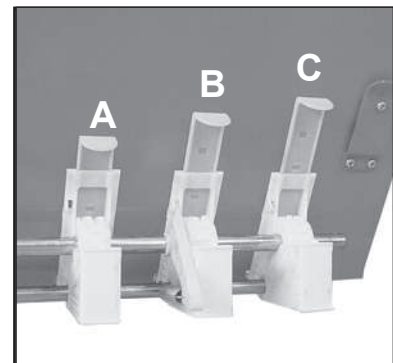

Fig 8

Bottom Flap Settings

The various seed sizes require matching bottom flap clearances below the metering wheel. The adjusting plate allows for 10 different settings. The required position for the seed type may be found in the Sowing Chart. The control levers are located on the LH end of the seedbox, (opposite end to the gearbox).

Number "1" corresponds to the minimum (closed) position and "10" the maximum gap (Fig 9).

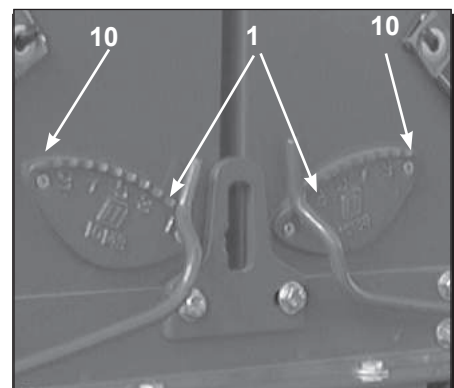

Fig 9

Basic Calibration Procedure (Continued)

Seed Calibration

The calibration test should be done to confirm the required seed rate and is done with the drill stationary and level.

Seed Calibration Procedures

- 1 Remove the calibration tray from the storage brackets on the seedbox. Place the calibration tray (1) on the support members below the seeders (Fig 10).
- 2 Position all the clear plastic seed diverters (2) to redirect the seed into the calibration tray (Fig 10).
- 3 Make sure all the shutters are open and set to the position indicated in the seed charts for the particular seed (Table 3. Page 17).
- 4 Agitator Shaft - Check the Seed Chart "Hints" (Table 3) whether to connect or disconnect the shaft by removing the lynch pins (1) during seeding (Fig 11).
- 5 For the test, half fill the box with seed. If this is not possible make sure the seed is evenly distributed within the box.
- 6 For setting method refer to Basic Calibration Procedures (Page 18).

Note For seeds which are not covered in the Sowing Chart (Page 17), use the figures for a seed of comparable size and shape.

7 Place the crank handle over the hexagonal drive dog on the transfer shaft and turn anti-clockwise until the seed flows consistently from the seeders (Fig 12). To ensure complete filling of the seed unit continue turning the crank until the calibration tray is approximately half full then empty into the seedbox. The drill is now ready for calibration.

8 Turn the crank handle anti-clockwise the required number of revolutions as detailed in Table 5.

Note The Calibration is usually done for 1/40th hectare. For very small seed rates or when using inaccurate scales (i.e. unable to measure to the nearest gram) the calculation based on 1/10th hectare should be used.

Scales must be accurate to 2 grams as any error will be multiplied by either 10 or 40 giving inaccurate calibration results.

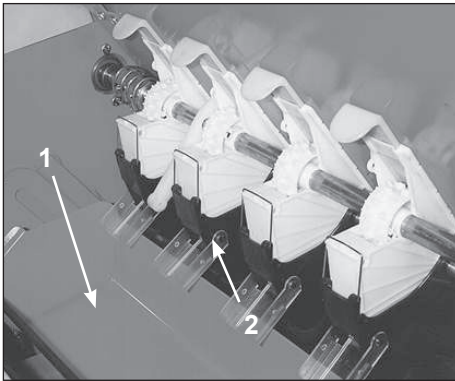

Fig 10

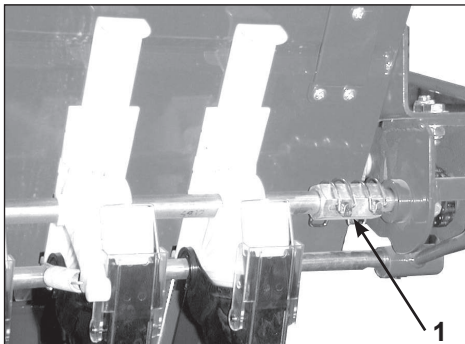

Fig 11

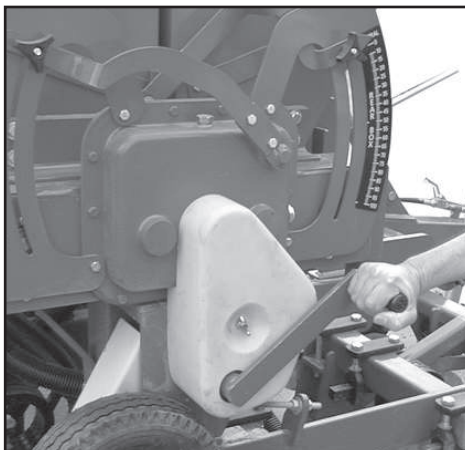

Fig 12

Basic Calibration Procedure (Continued)

Hand Crank Turns for Seed Rate Calibration

The tables represented below are for arable conditions (**worked ground**) and are calculated to indicate an average situation. If there is any doubt as to the accuracy of these figures for the conditions, it is advisable to run checks on the calibration figures listed. Refer Page 22, (**Wheel Slip Deviations**). Check and record which tyres are fitted to your drill, to ensure use of the correct Hand Crank Turn and Constant figures.

| Machine Size | Row Spacing(mm) | Sowing Width (m) | Turns for 1/40 Hectare | Turns for 1/10 Hectare |
|--------------|-----------------|------------------|------------------------|------------------------|
| 19 Run | 147.5 | 2.8 | 32.5 | 130 |

- 9 Weigh the seed collected during the test in kilograms.

Caution: Scales must be accurate to 2 grams, as any error will be multiplied by either 10 or 40, giving inaccurate calibration results.

- 10 Calculate the seed rate by multiplying the kgs previously collected x 40 (1/40th ha method, refer Table 6) or x 10 (1/10th ha method, refer Table 7) depending on the requirement. If the resultant calculation does not produce the desired seed rate use the enclosed seed rate calculator disc to determine the correct gearbox setting.

Refer **Use of Seed Rate Calculator** Page 21.

Suggestion: To be on the safe side and until confidence has been gained with the method of calibration it is advisable to conduct a second test at the newly determined gearbox setting.

- 11 Where a coated seed is used it is advisable to check the calibration after 1 hectare as dressings can tend to create a coating on the seed metering wheels thus changing the the flowing properties of the seed which in turn alters the seed rate.

| |
|--|
| <p>For $\frac{1}{40}$ Hectare (250m²) Calibration Seed Rate = Actual Seed Collected (kg) x 40</p> |
|--|

Table 6

| |
|---|
| <p>For $\frac{1}{10}$ Hectare (1000m²) Calibration Seed Rate = Actual Seed Collected (kg) x 10</p> |
|---|

Table 7

Basic Calibration Procedure (Continued)

Use of Seed Rate Calculator

Determining the gear box scale setting using the calculator.

Usually the first calibration test yields a different seed rate. However with the value determined from the first test it is possible to determine the correct gearbox setting with the aid of the enclosed disc calculator (Fig 13). The disc calculator consists of 3 scales. An outer white scale (1) for all seed rates above 30 kg/ha and an inner scale (2) for all seed rates below 30 kg/ha. On the middle coloured scale (3) are all the gearbox setting numbers to a maximum value of 100.

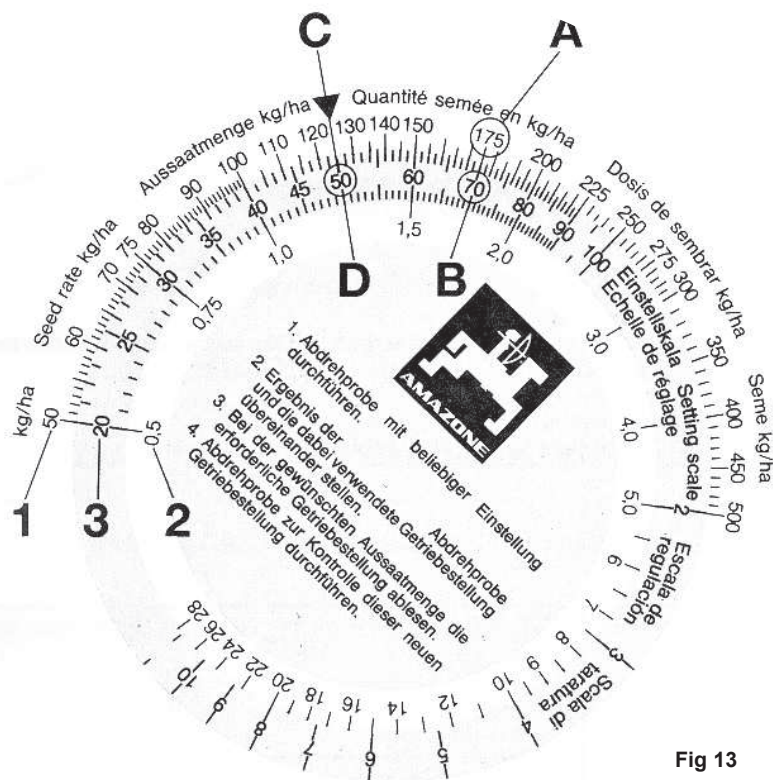

Setting Example (Desired Seed Rate 125kg/ha)

- 1 From the calibration procedure at a gearbox lever setting of "70", a seed rate of 175 kg/ha is obtained.
- 2 Turn the inner disc until the measured seed rate of 175kg/ha (A) is in line with the related actual gearbox setting of "70"(B) (Fig 13).
- 3 Read off from the disc rule the necessary gearbox setting for the required seed rate of 125kg/ha (C). In this example the correct setting is "50" (D) (Fig 13).
- 4 To be on the safe side the new gearbox setting can be checked by another calibration test.

Basic Calibration Procedure (Continued)

Calibration Deviations

Deviations Between the Calibration Test and the Actual Seed Rate

The most frequent cause for changes between the calibration test and the seed rate lies in the flowing properties of seed during sowing. These changes in properties generally result from reactions of the dressing agents to temperature, humidity or abrasion. These changes will become even more obvious when the bottom flaps are incorrectly set. If the setting of these flaps leaves too large a gap an uncontrollable additional flow of seed can occur during seeding; especially when assisted by the drill bouncing, a condition not simulated while conducting the calibration tests. For this reason the basic setting of the bottom flaps should be checked at regular intervals.

Residues from the seed dressing on the bottom flaps and metering wheels can also influence the flowing properties of the seed and thus the seed rate. In such cases a balance will occur only after a period of time and it is recommended to repeat the calibration test to confirm the seed rate after 2-3 seedbox fillings, nominally when the seed box is half empty. Only then will a balance occur and the seed rate will stabilise.

Wheel Slip Deviations

It is always possible with rubber tyred drills in extreme ground conditions to get wheel slip. Not normally a problem with cleated type tyres in good condition, but more so in the arable situation with the less aggressive tread patterns. The result: large differences between the calibration test and the actual sowing rate, obviously less seed deposited than required. The number of crank turns indicated below is correct in most circumstances other than those mentioned above.

To check number of crank turns for calibration

Should you require to check this in a practical way proceed as follows:

For an area of 250m² (1/40 Hectare), the travel distance for your machine is shown below. Place the crank handle over the hexagonal drive dog on the gearbox. Move the machine forward over the measured distance, counting the number of turns of the crank handle as you go. Using this number of crank turns repeat the calibration.

| Machine Size | Travel Distance (m) | Turns for 1/40 Hectare | Sowing Width (m) |
|--------------|---------------------|------------------------|------------------|
| 19 Run | 89.2 | 32.5 | 2.8 |

Hints for Sowing with Variable Speed Gearbox

The gearbox allows for stepless changes in the speed of the metering shaft and thus the seed rates. Due to the variations in seed type and application rates there are two speed ranges available.

By changing from High Speed to Low Speed the range of settings and control is dramatically increased.

Change to the Low Speed when the gearbox setting is down to 10 on the scale and the desired seed rate cannot be obtained.

To change the speed setting from high to low, remove the wing nut (1) and chain cover.(2) (Fig 14).

Release the tension on the chain (1) by forcing back the chain tensioner (2) and hold in place with the crank handle. Refer Figure 15. Remove the chain from the 21 tooth output sprocket to the 13 tooth sprocket, then remove the chain from the 13 tooth gearbox sprocket to the 21 tooth. Check the chain is correctly aligned then release the chain tensioner. Ensure the tension roller is correctly aligned with the chain. Replace guard and calibrate as required.

To Determine the Gearbox Setting after a Speed Change

For determining the correct gearbox setting after the speed change, conduct the first test at 50. With the weight of seed collected find your correct setting with the aid of the disc calculator, refer Page 19, Fig 13.

Sowing of Fine Seeds

For sowing fine seeds the Renovator Classic Drill is equipped as standard with a combined normal and fine seed "Elite" metering wheel (1). During grain sowing and other larger varieties of seed both the normal and fine seed metering wheels are coupled and both rotate. In order to convert the seed drill to sow fine seed insert the crank handle and rotate clockwise until the holes (2) of the fine seed wheel are visible (Fig 16)

Using the tool supplied (1) disengage the the pin inside the hole so that the normal metering wheel rotates freely on the metering shaft (Fig 17).

At this time it would be advisable to close any shutter slides not required for the fine seed sowing.

When seed is to be sown again using the normal metering wheel press the pin, from the normal metering wheel side (opposite direction to before), using the tool, back into the hole of the fine seed wheel thus reconnecting the drive between the two.

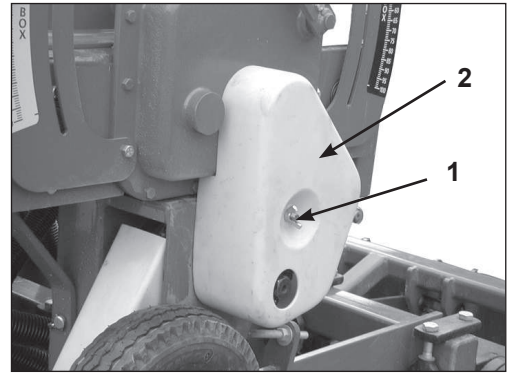

Fig 14

Low Speed Shown

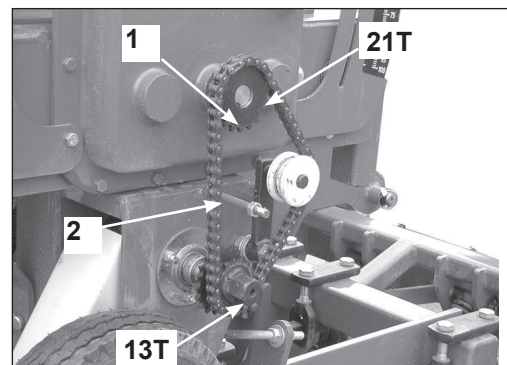

Fig 15

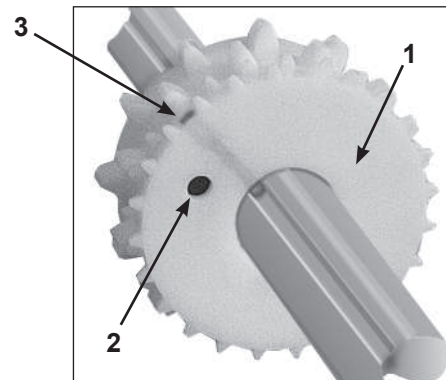

Fig 16

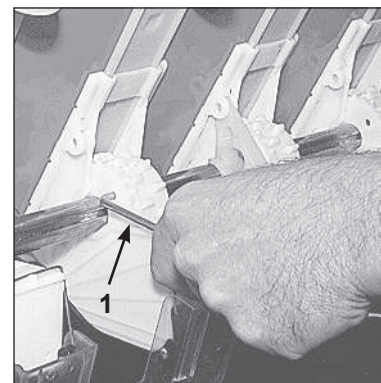
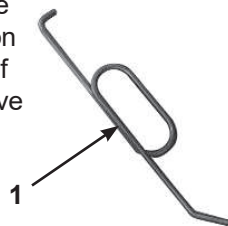

Fig 17



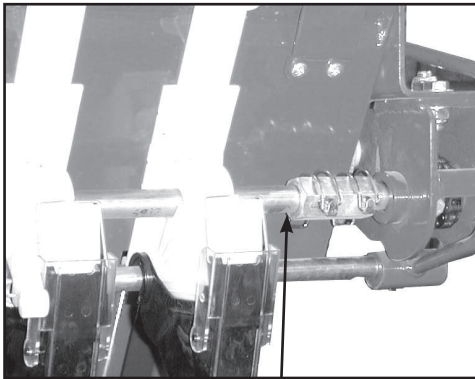

Fig 18

Small Seeds

Calibration with Disconnected Agitator Shaft

The fine seed metering wheel used in Duncan Drills is especially well suited for sowing small seeds such as rape. Due to the intensive action caused by the agitator the seeds can adhere to each other, or be damaged, causing irregular sowing/germination. **Therefore it is recommended that when sowing small seeds, especially oil seeds and thin shelled seeds, the drive to the agitator is disconnected.** To do this remove the lynch pin (1) (Fig 18).

Deviations between the calibrated and actual seed rate can occur when residual dressing agent sticks to the bottom flaps and thus slows the flow of seed. Before beginning the actual calibration test fill the calibration trays by turning the crank handle at a high speed around the 90 setting on the gearbox scale. This will cause an immediate buildup of the dressing agent on the flaps. Return the contents of the calibration trays to the seed box and proceed with the actual calibration. Due to the residue buildup on the flaps your calibration will now reflect accurately the required seed rate. It is advisable with small seeds to use the 1/10 hectare method for your calibration, thus cutting down on weighing errors.

Note - Remember to reconnect the agitator shaft as required for other seeds otherwise the consistency of seed rate will be affected.

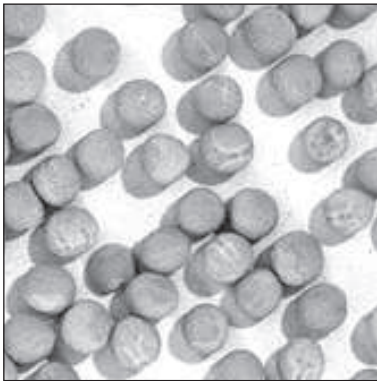

Fig 19

Sowing Peas

Peas having the size and shape as illustrated in Fig 19 (e.g. White Field Peas), can be sown without problems with all Clough Drills with this type of metering wheel.

The flap should be set to a gap of at least "3" on the flap setting lever (Page 16, Fig 9).

With these peas it should not be necessary to run the agitator shaft.

Peas having the size and shape as illustrated in Fig 20 (e.g. Green or Garden Peas), tend to bridge inside the seedbox and do not flow freely.

This multi-faceted pea requires agitation for sowing.

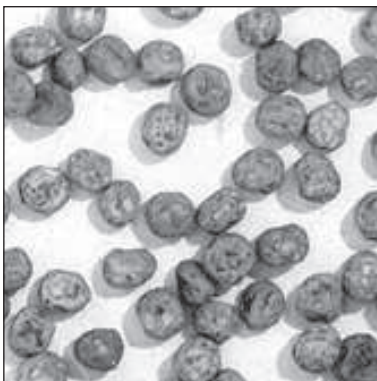

Fig 20



Caution - When resetting the metering wheels on the seeder shaft

Care should be taken when tightening the grub screws on the fine seed wheel (Page 23, Fig 16, item 3). Adjust the grub screw until the movement of the metering wheel just stops, then tighten no more than 1/8 of a turn.

Do not overtighten as this can result in breakages while operating and may render the warranty on these units void.

Farmscan Jackal Settings Setup

Refer to the manual supplied with your Farmscan Jackal kit for information and operation.

Farmscan Jackal Factory Setup for Renovator Classic

Refer to the Farmscan Jackal manual.

Input 2 -Three wire proximity sensor for 'Area/Speed Wheel' measurement taken from shaft on drive pedestal.
The white 'signal' lead is connected to input A2.

| Input 2 Edit | |
|---------------|-------------|
| m/pulse | |
| Auto Set: | |
| Target:0.000m | |
| Meas.pulses: | 0 |
| Manual Ratio: | 2.750000 |
| NEXT | EDIT |

| Other Settings | |
|------------------|-------------|
| Implement Width: | x.xxx m |
| Extern.Run/Hold: | Disabled |
| Alarm Beep:2 | |
| NEXT | EDIT |

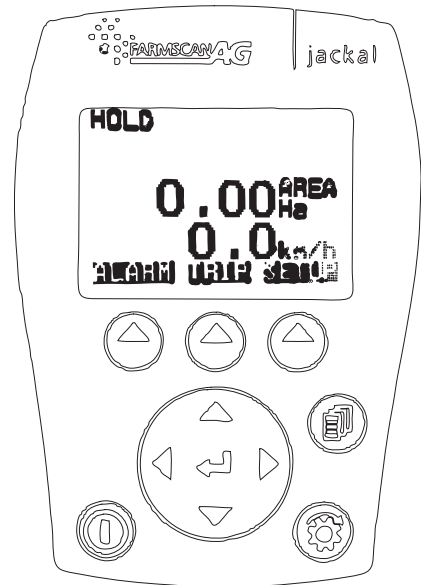

| Machine Size | Row Spacing (mm) | Sowing Width (m) |
|--------------|------------------|------------------|
| 19 Run | 147.5 | 2.802 |

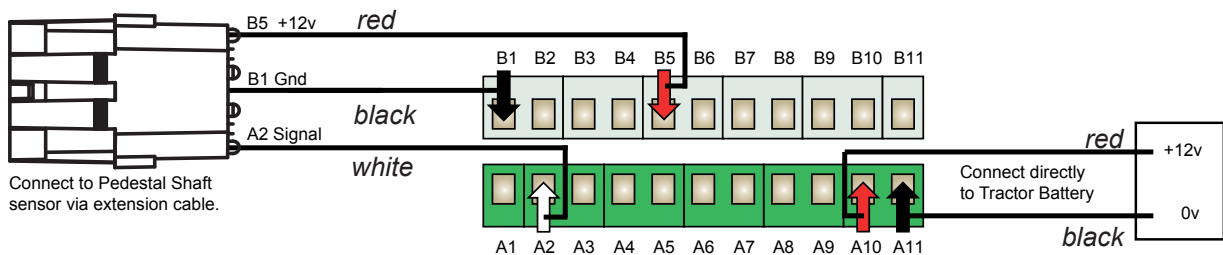

Refer to the Farmscan manual if you want to make additional sensor connections.

It is advisable, as with all things electronic, to have a backup of your totals. We suggest you record these on a daily basis in a notebook or diary.

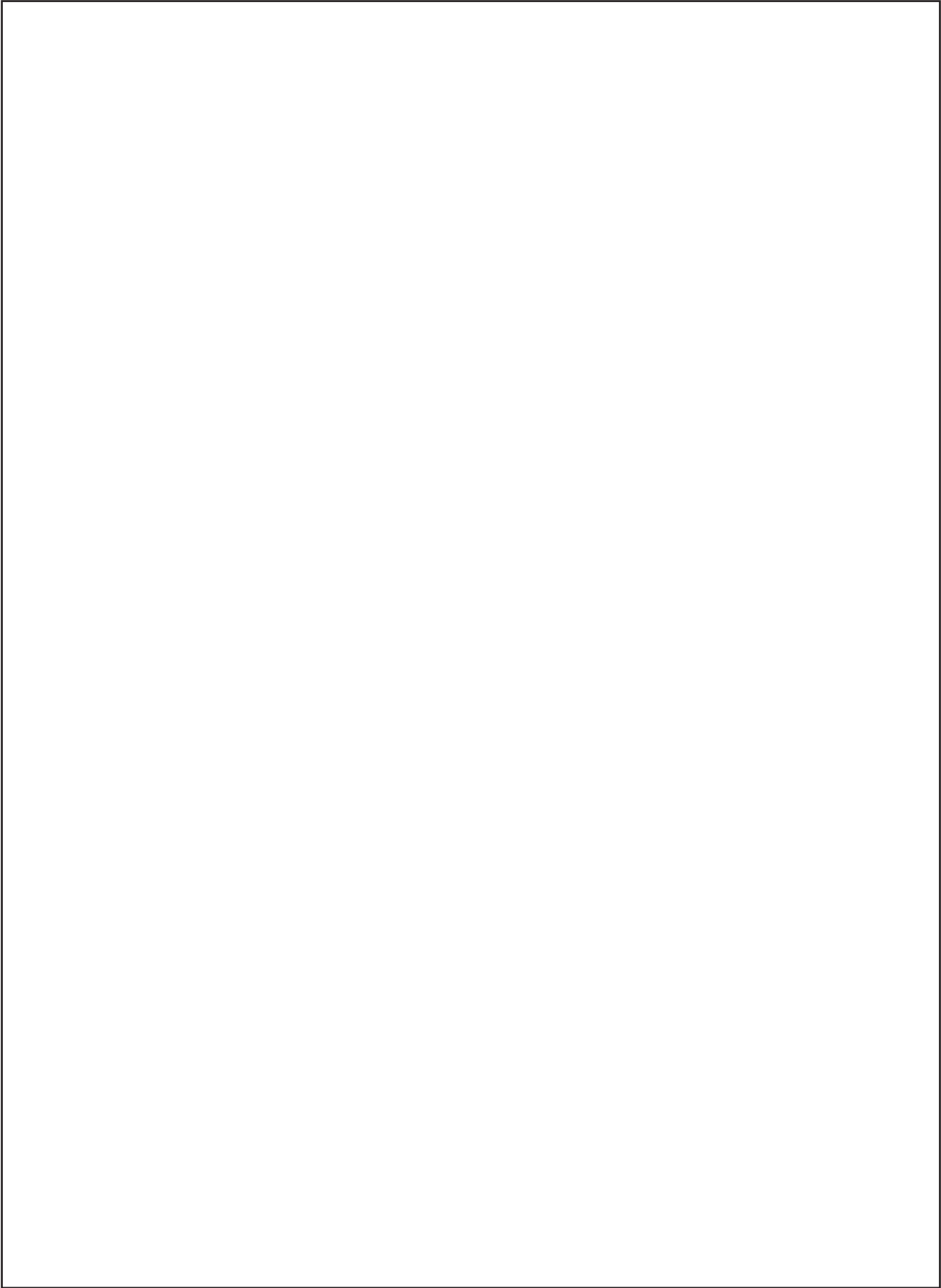

Maintenance & Care

General Safety and Accident Prevention Advice



- 1 Make sure that if the tractor remains attached to the drill that the ignition key is removed.
- 2 During maintenance the drill should be supported in such a manner that if hydraulic failure was to occur the machine would still be adequately supported.
- 3 Wear gloves when handling components with cutting edges such as worn discs etc...
- 4 Disconnect the electrical supply from the tractor before doing any electrical maintenance.
- 5 Refer to safety sections for more safety information.

General Cautionary Maintenance Advice



- 1 **Electric Welding** - With the electronic equipment in modern tractors it is advisable to completely disconnect the implement from the tractor, or at the very least disconnect the alternator before attempting any welding.
- 2 **Hydraulics** - Ensure hydraulic couplings (male & female) are clean before connecting. Dirty couplings will result in hydraulic oil contamination and hydraulic cylinder seal damage and bore scores. This in turn will result in oil leakage past the piston seals.

No filter is fitted to the hydraulic system. If hydraulic fittings and oil supply are not going to be kept clean it is recommended that a filter be fitted to prevent hydraulic cylinder damage.
- 3 **Water Blasting** - Water blasting, steam cleaning or other pressurised cleaning processes can force dirt etc. into undesirable places that may cause damage or rapid part wear to items such as bearings, seals, chains, bushes etc. Caution must be exercised.
- 4 Box set lifting eye profile - these profiles are provided for easy removal of the dual boxes from the side frames.
Do not use when boxes are loaded nor to lift machine.

Maintenance & Care - Lubrication Instructions

Precautions with Grease

Greases should not be mixed as the structure may be weakened by the mixes of different types of thickener, which may cause softening and loss of grease from the bearings by running out.



Your new Duncan 'Renovator Classic' Seed Drill will give long and efficient service if given normal care and maintained properly.

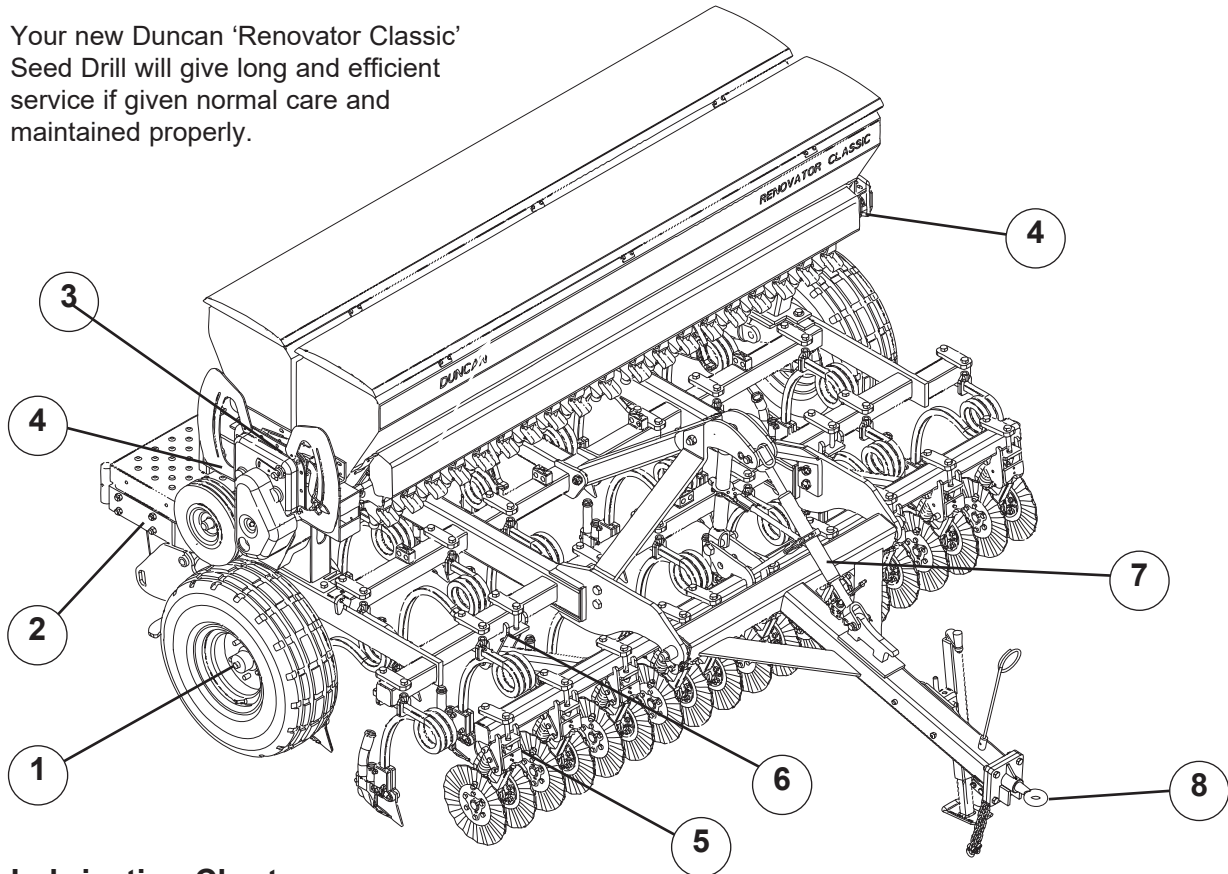

Lubrication Chart

| Item | Components | Lubricant | Frequency |
|------|------------------------|---------------------------------|--------------------------|
| 1 | Wheel Bearings | Castrol LMX Grease | Annually |
| 2 | Wheel Leg Pivots | Castrol LMX Grease | Weekly |
| 3 | Gearbox | Castrol Oil Agri Trans Plus | Maintain Level |
| 4 | Drive Chains | Suitable Roller Chain Lubricant | See Maintenance Schedule |
| 5 | Disc Arm Castings | Castrol LMX Grease | Daily |
| 6 | Disc Opener Fr. Pivots | Castrol LMX Grease | Monthly |
| 7 | Turnbuckles | Castrol LMX Grease | Monthly |
| 8 | Coupling | Castrol LMX Grease | Weekly |

* The lubrication frequencies are only a guide. Actual frequency will be dependent on extent of use and ground conditions.

Maintenance & Care - Lubrication Instructions

| Components | Daily (or after 20Ha) | Weekly (or after 75Ha) | Pre Season (or 500 Ha) |
|--------------------------------|--------------------------|---------------------------|---------------------------|
| Disc Openers | • | • | • |
| Depth Adjustment Collar | • | • | • |
| Seeders/Agitators/Bottom Flaps | • | • | • |
| Wheel Nuts | • | • | • |
| Pivot Pin Fasteners | | • | • |
| Coupling & Safety Chains | | • | • |
| Roller Chains | | • | • |
| Gearbox | | • | • |
| Hydraulics (Oil Leaks) | | • | • |
| Tyre Pressures | | • | • |
| Bolted Connections | | | • |

Maintenance Schedule

(Refer also to Summary Chart, above)

1 Bolted Connections

All bolted connections of the machine should be checked after the first 3 to 5 hours of operation and retightened if necessary and thereafter at regular intervals. It is suggested that this is done every 500 hectares or annually, whichever occurs first.

2 Gearbox

The oil level in the gearbox can be seen in the oil gauge window. Changing the gearbox oil is recommended once a year or sooner if the oil is discoloured. For refilling the oil remove the 1/2" BSP plug on the top face of the gearbox, Castrol Oil Agri Trans Plus or equivalent* should be used.

The total filling capacity is 1.25 litres.

DO NOT OVERFILL.

**Oil Specification to meet the requirements of : SAE 10W-30, API GL-4, Massey Ferguson M1143, John Deere J20C, J20D, Case MS 1207, Ford/New Holland M2C-134D, M2C-86 A/B/C*

3 Drive Chains

All drive chains (1) (Fig 25) should first be checked after every 20 hours of operation and thereafter weekly or after 75Ha of operation as follows:-

The metering wheels of the seed drill are driven via roller chains from the drive wheel.

Cleaning of the roller chains is recommended after long periods of operation. Remove the chain, wash in kerosene and then dip them in heated grease or oil or spray them with a suitable commercial roller chain lubricant.

4 Wheel Rocker Pivots

Wheel rocker pivots (4 per machine) must be greased regularly (weekly or after every 75Ha) to provide lubrication and flush out any dirt. Refer Fig 26 (1).

5. Depth Adjustment Collar

Grease the depth adjustment collar (1) regularly to ensure it does not seize up. Also check for dirt buildup around the ram shaft seals to ensure seal damage does not occur. Refer Fig 27

6. Tyre Pressure

Refer to Dimensions & Capacities Page 5. Check the tyre pressures regularly to ensure correct pressure is maintained. Weekly checks are recommended.

7. Disc Openers

Front coulter bearings are sealed and do not require lubrication. Check discs for any lateral movement (wobble) on a regular basis. Replace bearings if there is any noticeable wobble.

There is one grease nipple on each disc opener frame pivot and disc assembly casting. Frame pivots should be greased monthly while disc castings should be greased daily to provide lubrication and to flush out any dirt.

8. Length of Seed/Fertiliser Tubes

These tubes can stretch over a period of time and require checking at approximately six monthly intervals. Shorten if necessary to avoid bends which will restrict the flow of seed/fertiliser.

9 Framework

The framework structure should be inspected annually for defects, i.e., cracks in members or welded connections. The framework should be cleaned prior to the inspection.

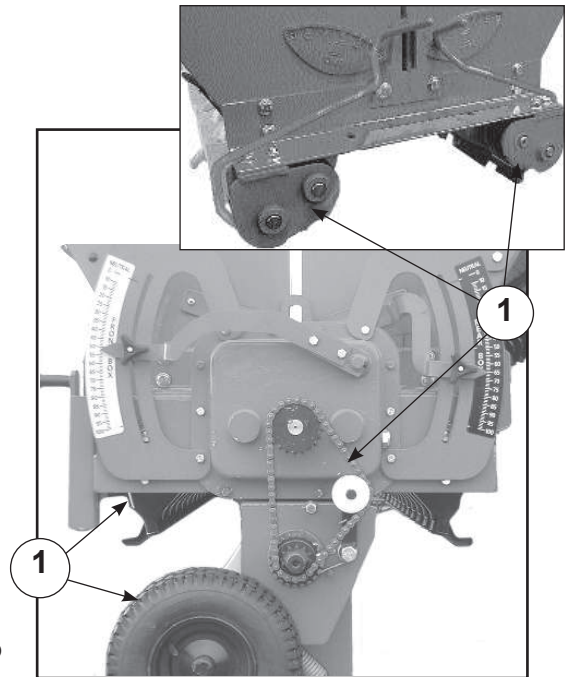

Fig 25

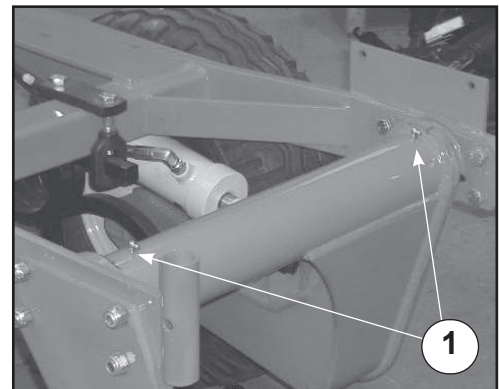

Fig 26

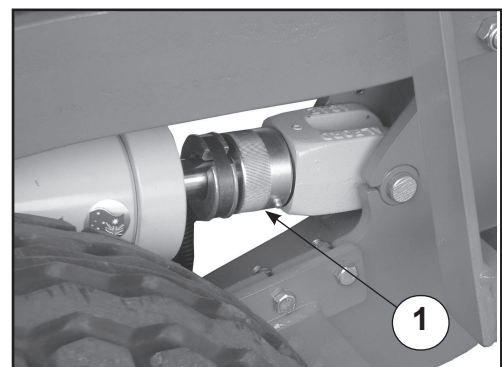

Fig 27

Maintenance & Care (Continued)

10 Bottom Flaps (Fig 28)

The required seed rate is controlled by both the metering wheels and the bottom flaps. The seed flows from the seed box into the metering wheel housings. Inside the metering wheel housing (1) the seed is caught between the metering wheel (2) and the bottom flap (3). The metered amount of seed is transported by the metering wheel to the edge of the bottom flap where it drops off into the seed guide tube which leads to the coulter. Varying grain sizes require the matching of the flap clearance to the different grain sizes. This matching is done by raising or lowering the bottom flaps by using the flap adjusting lever on the LH end of the seed box. If larger foreign particles, e.g. stones get between the metering wheel and the bottom flap, the bottom flap can give way downwards. A strong return spring (4) brings the bottom flap immediately back into the working position.

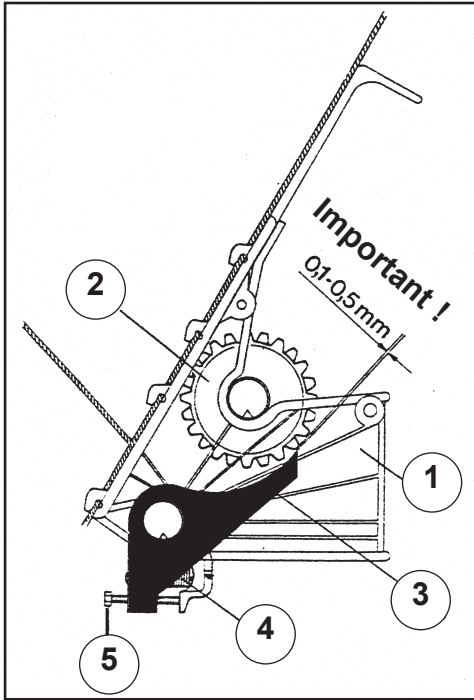

Fig 28

The metering system should be checked every 1/2 year or before any sowing period with an empty seed box and empty metering housings.

Use the following procedure:

Put the bottom flap setting levers (1) (located on the LH end of the seed boxes) in position "1" for the front box and position "1" for the rear box. Refer Fig 29.

By turning the metering wheel shaft by hand check the flaps are all set to a gap of 0.1 to 0.5mm (refer Fig 28).

To adjust individual flaps use the spring tensioning screw (5) (Fig 28).

Note: Maintenance Schedule (page 30)

Where the frequency is given in terms of use (eg. weekly) or area covered (eg. 75 Ha) perform the maintenance task based on whichever occurs first.

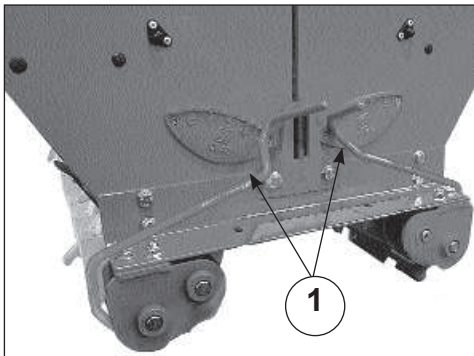

Fig 29

Preparing the Machine for Storage.

Locate on a dry level surface. The machine should be stored wherever possible so the rams are not supporting any weight. The drive chains should be lubricated with suitable roller chain lubricant before prolonged periods of storage.

For longer term storage remove seed/fertiliser tubes from the boot assembly and allow to hang without deformation. Check tube lengths when replacing.

It is recommended that maintenance be carried out at the end of the season, giving sufficient time to obtain spare parts and/or carry out repairs if required.

Renovator Classic Troubleshooting

| Problem | Possible Cause | Action | Refer to Page... |
|---|--|---|-------------------------|
| Over Sowing | Jockey wheel under inflated | <i>Check pressure</i> | 5 |
| | Are the hectare meter settings correct? | <i>Check settings</i> | 25 |
| | Has the calibration procedure been followed correctly? | <i>Re-calibrate</i> | 18-22 |
| | Is the shutter slide open too wide? | | 18-22 |
| | Is the flap setting open too wide? | <i>Check settings</i> | 18-22 |
| | Too larger gap between seeder unit & bottom flap (should be 0.3mm when on setting 1) | <i>Check settings</i> | 32 |
| | Quadrant Tri-knob coming loose | <i>Check gap</i> | 18 |
| Under Sowing | Has the calibration procedure been followed correctly? | <i>Re-calibrate</i> | 18-22 |
| | Is the correct gear ratio selected? | <i>Check setting</i> | 18, 23 |
| | Sowing at shallow depths. Is there sufficient pressure on the jockey wheel? | <i>Check and adjust spring pressure</i> | |
| Drill not sowing until quadrant levers are well down on the scale/each box is sowing at different rate even when both set on the same setting | The two bolts on the quadrant lever have come loose | <i>Check and reset</i> | 53 |
| | Transfers may not be aligned with each other | | |
| Drill sowing deeper on one side/leaking down on one side | Hydraulic lift rams have not rephased properly | <i>Rephase rams</i> | 34 |
| | Dirt in the poppet valve of the ram | <i>Clean/replace valve</i> | 34 |
| Tines are moving | Too much turning with drill in the ground | <i>Keep turning to minimum</i> | |
| Drill not penetrating into ground/drill riding out of ground | Operating drill in the float position | <i>Do not operate in float</i> | 15 |
| | Disc openers are keeping the drill from penetrating into the ground | <i>Lift discs out of the ground</i> | 16 |

Commissioning PTE Phasing Cylinders

1. General

(a) PTE cylinders will re-phase in both directions. Each piston is fitted with 2 poppet valves which open at the end of the stroke to allow oil to bypass the piston. The bypass of oil at the end of the stroke allows for initial bleeding of the system and re-phasing in operation.

(b) The valve in the piston is a precision device, **CLEANLINESS IS OF THE UTMOST IMPORTANCE**. Contamination in the oil will accelerate deterioration of the valve seat. Cylinders will creep once the integrity of the seating is lost.

2. Bleeding the System

(a) Initial bleeding after connection to the tractor

Purge all air from the system by fully stroking rams in both directions. Allow the oil to flow through the cylinders with the tractor at an idle for a minimum of 2 minutes at each end of the stroke.

(b) Re-phasing after initial bleeding

After initial bleeding the cylinders will only require occasional re-phasing during operation. This is done by extending the rams for about 30 seconds or until all cylinders have reached the end of their stroke.

3. Fault Finding

1. Cylinders creeping during operation

There are two primary causes of this:

- (i) Air in the hydraulic system
- (ii) By passing of the poppet valve.

(a) Check that there is no air in the system. Raise and lower the machine. All cylinders should move instantaneously, any lag indicates that there is air in the system. Other signs of air in the system are hoses vibrating/squealing or the control handle shuddering. Re-bleed the system if necessary.

(b) If there is no sign of air in the system and the cylinders still creep, raise the machine off the depth stop and measure the movement of each cylinder rod.

(c) If both cylinders move at the same rate it is likely to be the control valve/lock out valve that is leaking.

(d) If the slave continues moving after the master cylinder has hit the depth stop it is likely to be the piston in the master cylinder that is bypassing.

(e) If the slave cylinder extends while the master cylinder retracts it is likely to be the piston in the master cylinder that is bypassing.

(f) If the master cylinder does not move but the slave does it is likely to be the piston in the slave cylinder that is bypassing.

(g) If the piston is bypassing it is likely to be contamination in the phasing valve. The cylinder will have to be dismantled, cleaned and fitted with a new poppet valve.

Commisioning PTE Phasing Cylinders (continued)

3. Fault Finding (continued)

2. Cylinders moving at different rates

(a) Check that there is no air in the system. Raise and lower the machine; all cylinders should move at the same time, any lag indicates that there is air in the system. Re-bleed the system if necessary.

(b) Ensure that the cylinders have been connected correctly. The cylinders should be connected in series so that the bore sizes go down in 1/4" increments. The Rod end port of the master cylinder (3.5" bore) is connected to the piston end port of the slave cylinder (3.25" bore).

Parts List



'Renovator Classic'

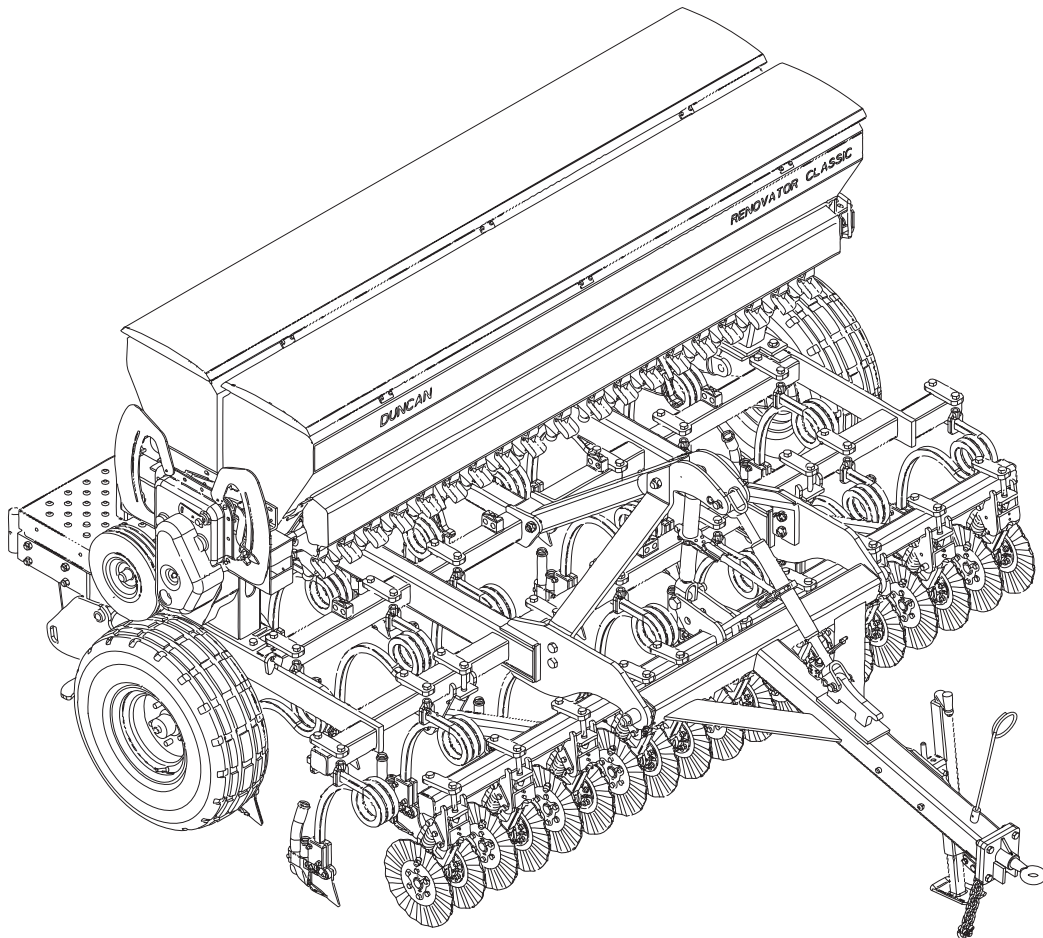

Built to work.

Timaru Branch:
100 Hilton Highway, Washdyke,
Timaru, New Zealand
Tel: +64 3 688 2029
Email: timadmin@giltrapag.co.nz
Web: www.giltrapag.co.nz

Australian Branch:
105-117 Boundary Road,
Laverton North, Melbourne,
VIC 3026, Australia
Tel: +61 3 9369 6548
Email: admin@giltrapag.com.au
Web: www.giltrapag.com.au

Pt. No. 67388
Rev 0824

'Renovator Classic' Complete Assembly

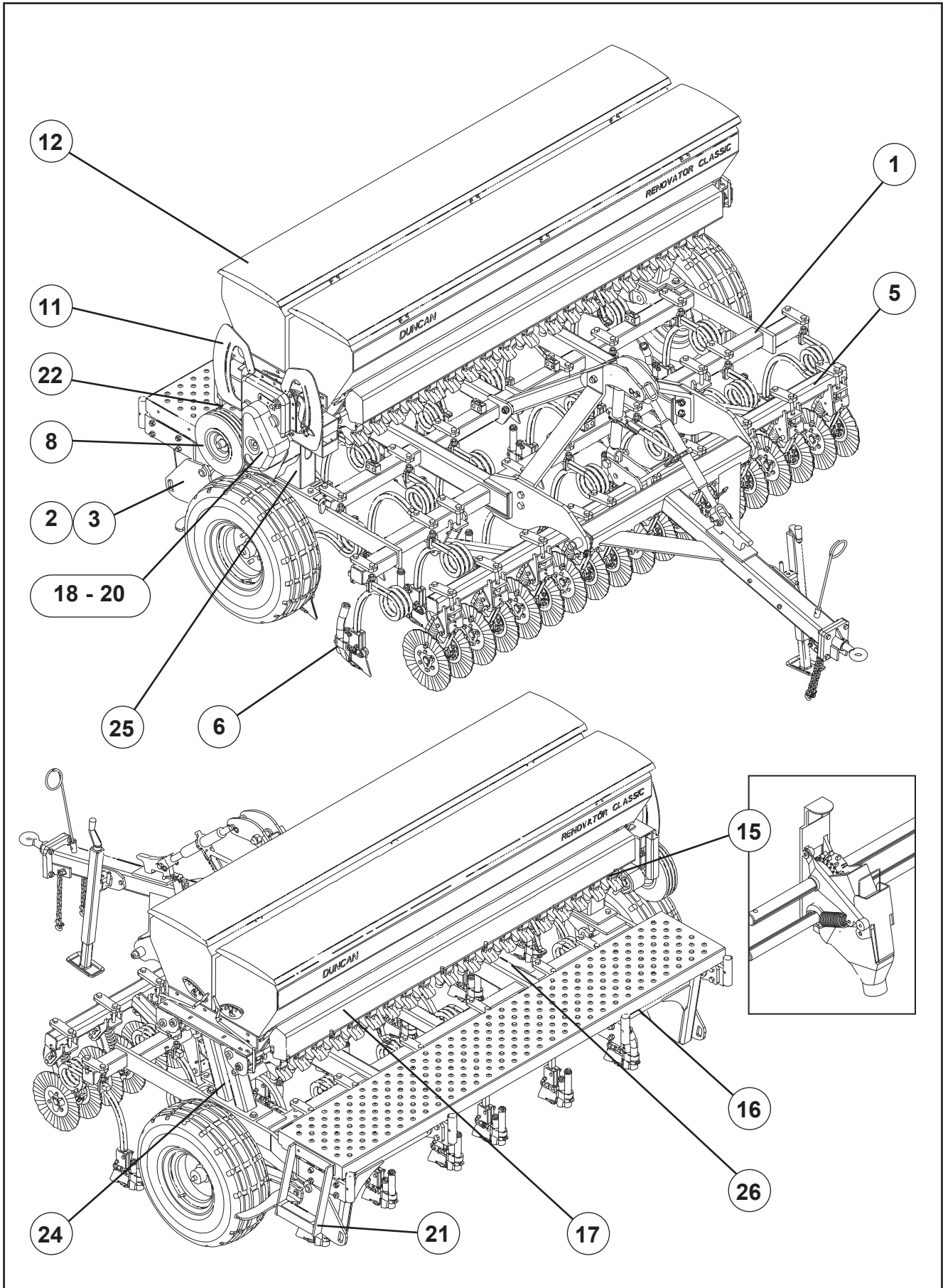

‘Renovator Classic’ Complete Assembly

| ITEM | PART No. | DESCRIPTION | QTY |
|------|-------------------|--|-----|
| 1 | Refer pages 40-43 | Main Frame and Drawbar Assembly | 1 |
| 2 | Refer page 44 | Wheel Leg | 1 |
| 3 | Refer page 46 | Wheel Hydraulics | 1 |
| 4 | Refer page 68 | Wiring and Lighting (Optional - not shown) | 1 |
| 5 | Refer page 64 | Disc Opener Assembly (Optional) | 1 |
| 6 | Refer page 48 | Tine and Boot Assembly | 19 |
| 7 | Refer page 50 | Drive Chains (Not shown) | 4 |
| 8 | Refer page 56 | Jockey Wheel and Transfer Drive System | 1 |
| 9 | Refer pages 63 | Hectaremeter Kit (Optional - Not shown) | 1 |
| 10 | Refer page 54 | Seed Box Drive Shafts | 2 |
| 11 | Refer page 55 | Gearbox Final Assembly | 1 |
| 12 | Refer page 58 | Seedbox Assembly | 2 |
| 13 | Refer page 60 | Agitator Drives | 2 |
| 14 | Refer page 61 | Agitator Shaft Assembly (Inside Seedbox) | 2 |
| 15 | Refer page 62 | Seeder Mechanism | - |
| 16 | 26623 | Footboard Assembly | 1 |
| 17 | 22562 | Calibration Tray | 4 |
| 18 | 25995 | Drive Guard | 1 |
| 19 | 25730 | Jockey Arm Tension Spring | 1 |
| 20 | 25723 | Jockey Arm Tension Eyebolt | 1 |
| 21 | 26575 | Footboard Step | 1 |
| 22 | 22051 | Crank Arm and Handle Assy | 1 |
| 23 | 22916 | 3.0m Weather Skirt (Optional) | 2 |
| 24 | 22541 | LH Pedestal W/Assy (Dual) | 1 |
| 25 | 26562 | Drive Pedestal W/Assy | 1 |
| 26 | 26599 | Calibration Tray Bracket | 8 |

'Renovator Classic' Mainframe and Drawbar

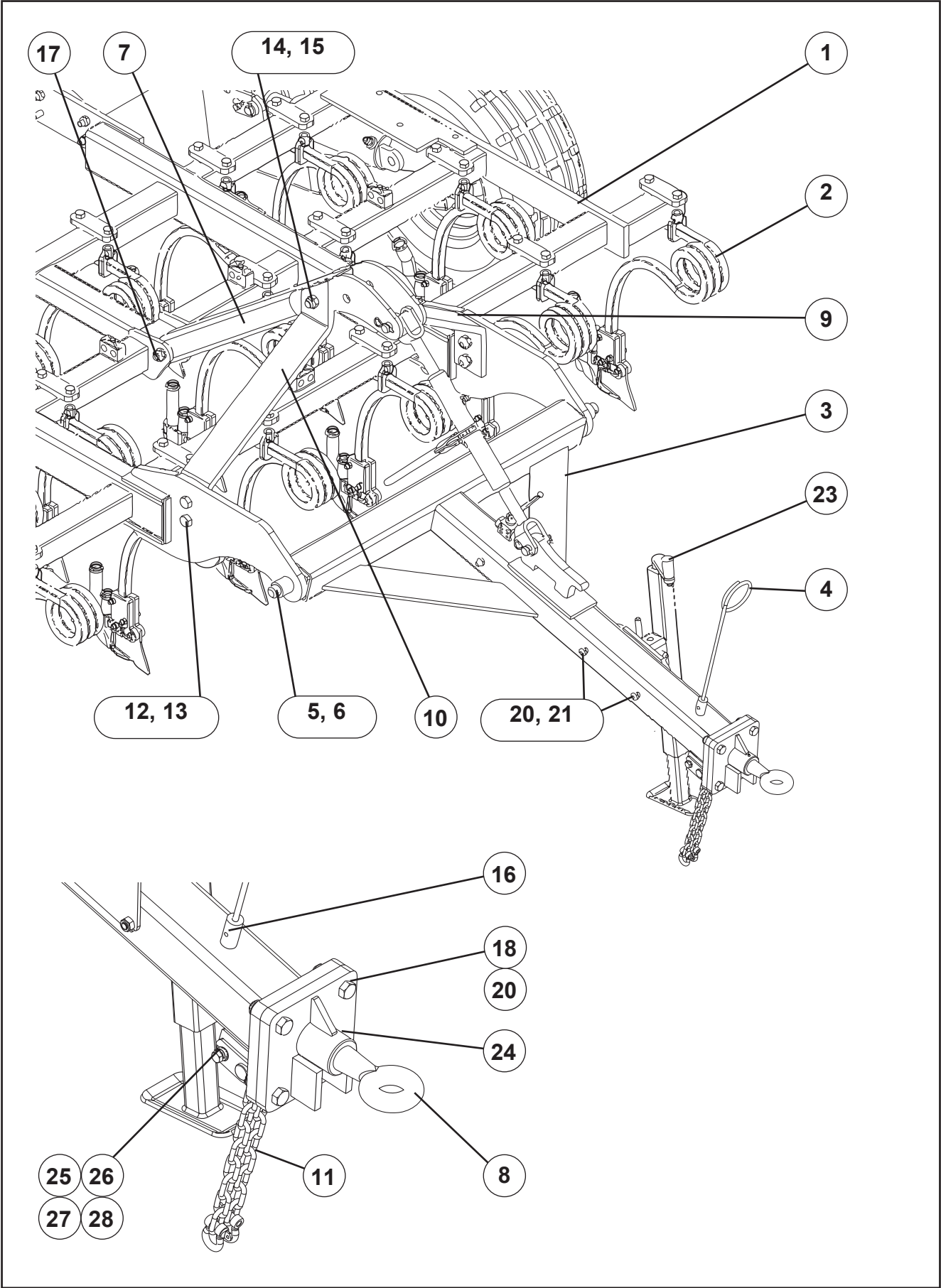

‘Renovator Classic’ Mainframe and Drawbar

| ITEM | PART No. | DESCRIPTION | QTY |
|------|---------------|--------------------------------|-----|
| 1 | 26512 | 19R Mainframe | 1 |
| 2 | Refer page 48 | Coil Tines & Boots | - |
| 3 | 26550 | Drawbar Assembly | 1 |
| 4 | 4800315 | Hose Support | 1 |
| 5 | 60094 | Drawbar Axle | 1 |
| 6 | 45285 | Roll Pin Ø10 | 2 |
| 7 | 60192 | Centre Hitch Welded Assembly | 1 |
| 8 | 26580 | Towing Eye Assembly | 1 |
| 9 | 26577 | LH Support Stay | 1 |
| 10 | 26578 | RH Support Stay | 1 |
| 11 | 43830 | Safety Chain Assembly | 2 |
| 12 | 45066 | M20 x 70 Grade 8.8 Bolt | 4 |
| 13 | 45141 | M20 Nyloc Nut | 6 |
| 14 | 47244 | 7/8" UNF Bolt x 6.5" | 1 |
| 15 | 47548 | 7/8" UNF Nut | 1 |
| 16 | 45181 | M8 x 12 S/H Grub Screw | 1 |
| 17 | 45075 | M20 x 150 Grade 8.8 Bolt | 1 |
| 18 | 45042 | M16 x 60 Grade 8.8 Bolt | 4 |
| 19 | 45140 | M16 Nyloc Nut | 4 |
| 20 | 45033 | M12 x 120 Grade 8.8 Bolt | 2 |
| 21 | 45139 | M12 Nyloc Nut | 3 |
| 23 | Refer page 70 | Jack Stand Kit – Optional | 1 |
| 24 | 43007 | Grease Nipple | 1 |
| 25 | 22262 | Clevis Pin Tabbed | 1 |
| 26 | 45001s | M10 x 20 S/Screw Grade 8.8 Z/P | 1 |
| 27 | 45152 | M10 Light Flat Washer | 1 |
| 28 | 45166 | M10 Spring Washer | 1 |

'Renovator Classic' Mainframe and Drawbar

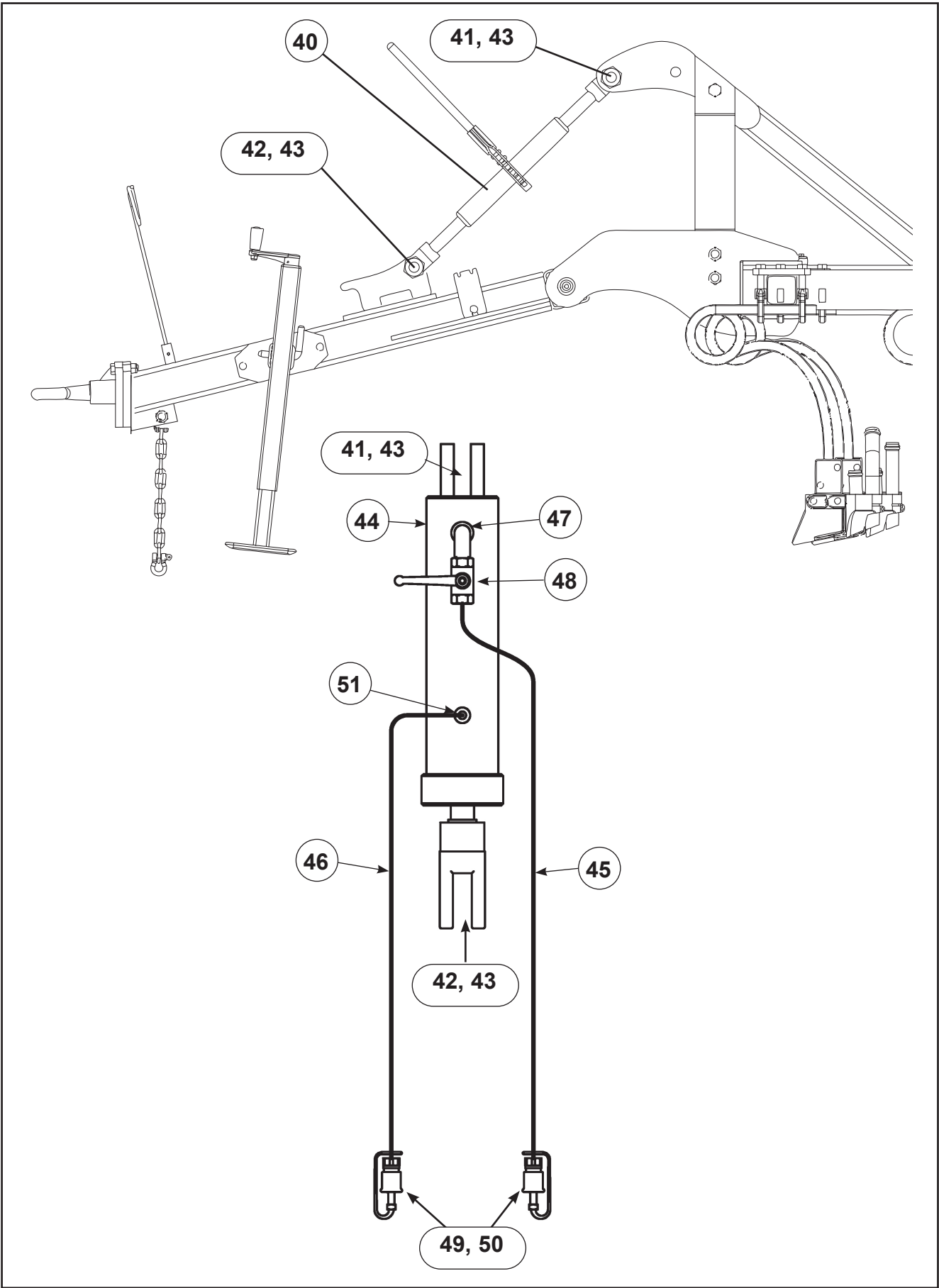

'Renovator Classic' Mainframe and Drawbar

| ITEM | PART No. | DESCRIPTION | QTY |
|------|----------|---------------------------------|-----|
| 40 | 43395 | H/D Ratchet Turnbuckle | 1 |
| 41 | 47254 | Bolt 1" UNF x 5" HT | 1 |
| 42 | 47251 | Bolt 1" UNF x 3.5" HT | 1 |
| 43 | 47552 | 1" UNF Nyloc Nut | 2 |
| 44 | 43852 | Hydraulic Cylinder | 1 |
| 45 | 26723 | Hydraulic Hose 2.80m | 1 |
| 46 | 26724 | Hydraulic Hose 2.50m | 1 |
| 47 | 43496 | 3/4" UNO to 3/8"BSPT Elbow | 1 |
| 48 | 43393 | 3/8" BSP S/S Ball Valve | 1 |
| 49 | 43147 | 1/2" BSP Quick Release Coupling | 2 |
| 50 | 43617 | Dust Cover | 2 |
| 51 | 43280 | 3/4" UNO to 3/8" BSPM Nipple | 1 |

Note: Drawbar hydraulic parts (41-51) can be purchased as a kit, part number 26720K.

'Renovator Classic' Wheel Rocker System

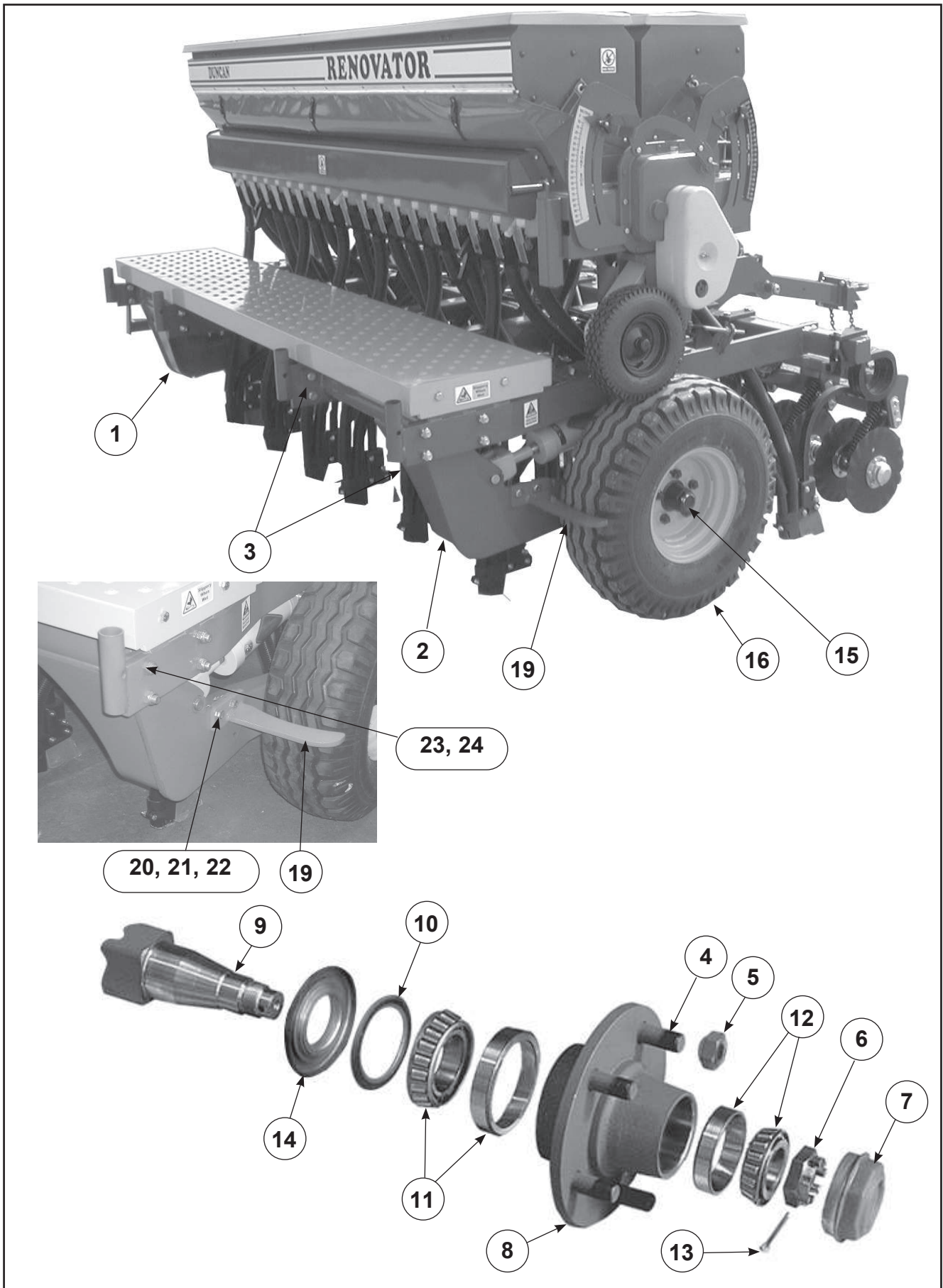

'Renovator Classic' Wheel Rocker System

| ITEM | PART No. | DESCRIPTION | QTY |
|------|----------|---|-----|
| 1 | 62013 | LH Wheel Rocker Welded Assy | 1 |
| 2 | 62014 | RH Wheel Rocker Welded Assy | 1 |
| 3 | 26585 | Rocker Pivot Assy | 4 |
| 4 | 43596 | ADR M16-1.5P x45 Hub Stud | 10 |
| 5 | 43597 | ADR M16-1.5P Wheel Nut | 10 |
| 6 | 43598 | ADR M27-1.5P Castle Nut | 2 |
| 7 | 43599 | ADR 62mm Hub Cap | 2 |
| 8 | 43600 | ADR Hub MkII | 2 |
| 9 | 26620 | ADR MkII Stub Axle (Welded to Wheel Rockers) | 2 |
| 10 | 43976 | Seal Kit | 2 |
| 11 | 43421 | 30209 J2 Inner Bearing | 2 |
| 12 | 10282 | 30206 J2 Outer Bearing | 2 |
| 13 | 45303 | 3.5 Diameter x 40 Long Cotter Pin | 2 |
| 14 | | Trash Shield (part of item 10) | 2 |
| 15 | 43836 | Mk 2 ADR Hub and Stub Assembly Complete (Items 4-14) | 2 |
| 16 | 43833 | Wheel 10/80-12 | 2 |
| 17 | 26592 | Rocker Shaft Plug (Not Shown) | 4 |
| 18 | 62028 | LH Wheel Scraper Assy | 1 |
| 19 | 62029 | RH Wheel Scraper Assy | 1 |
| 20 | 45437 | M12x 50 Bolt | 4 |
| 21 | 45139 | M12 Nyloc Nut | 4 |
| 22 | 45153 | M12 Light Flat Washer | 4 |
| 23 | 45042 | M16 x 60Grade 8.8 Bolt | 16 |
| 24 | 45140 | M16 Nyloc Nut | 16 |
| 25 | 43120 | M8 x 1.25 Pitch Grease Nipple x 90 degree (Not Shown) | 4 |

'Renovator Classic' Wheel Rocker Hydraulics

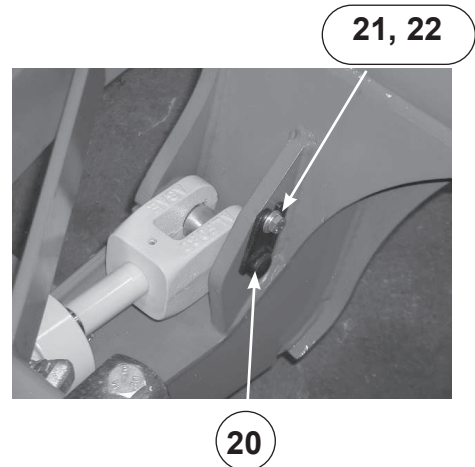
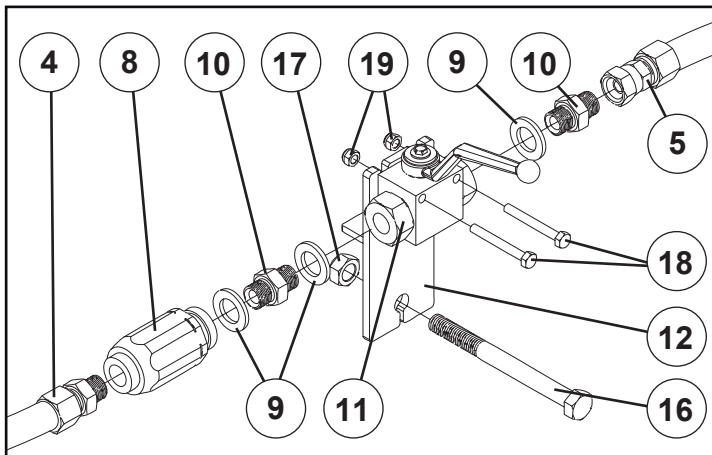
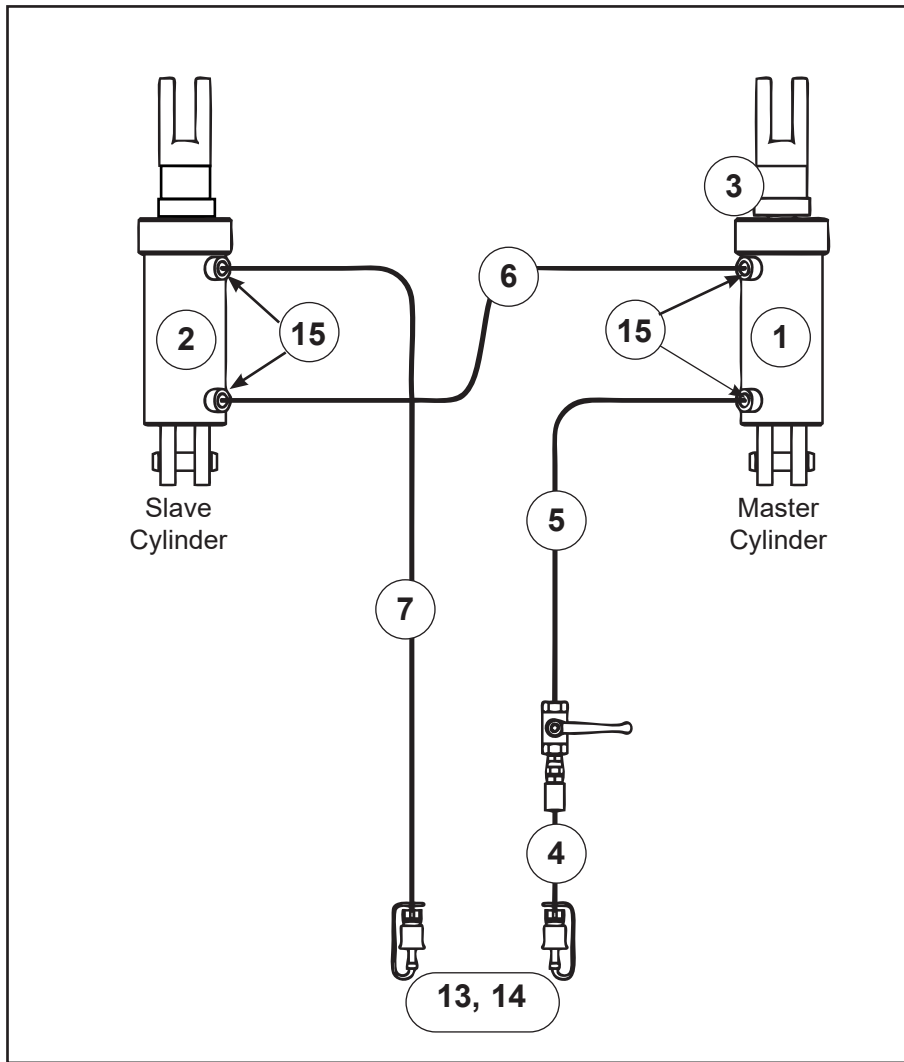

'Renovator Classic' Wheel Rocker Hydraulics

| ITEM | PART No. | DESCRIPTION | QTY |
|------|----------|--|-----|
| 1 | 26702 | 3.5" x 6.5" Master Rephasing Cylinder (Includes pin) | 1 |
| 2 | 26703 | 3.25" x 6.5" Slave Rephasing Cylinder (Includes pin) | 1 |
| 3 | 43848 | Stroke Limiting Collar 7/8" (where fitted) | 1 |
| 4 | 60866 | Hydraulic Hose, 2.70m | 1 |
| 5 | 26713 | Hydraulic Hose, 2.33m | 1 |
| 6 | 26714 | Hydraulic Hose, 2.80m | 1 |
| 7 | 26715 | Hydraulic Hose, 5.30m | 1 |
| 8 | 43028 | 3/8" Flow Control | 1 |
| 9 | 43391 | 3/8" Dowty Washer | 3 |
| 10 | 43392 | 3/8" BSPP Male Nipple | 2 |
| 11 | 43393 | 3/8" BSP S/S Ball Valve | 1 |
| 12 | 60856 | Hydraulic Valve Support Assy | 1 |
| 13 | 43147 | 1/2" BSP Quick Release Coupling | 2 |
| 14 | 43617 | Dust Cover | 2 |
| 15 | 43280 | 3/4" UNO to 3/8" BSP Nipple | 4 |
| 16 | 45033 | M12 x 120 Bolt | 1 |
| 17 | 45139 | M12 Nyloc Nut | 1 |
| 18 | 44957 | M6 X 50 Bolt | 2 |
| 19 | 45136 | M6 Nyloc Nut | 2 |
| 20 | 22262 | Clevis Pin Assembly | 2 |
| 21 | 45418s | M10 x 25 Set Screw | 2 |
| 22 | 45166 | M10 Spring Washer | 2 |

'Renovator Classic' Tine and Boot Assembly

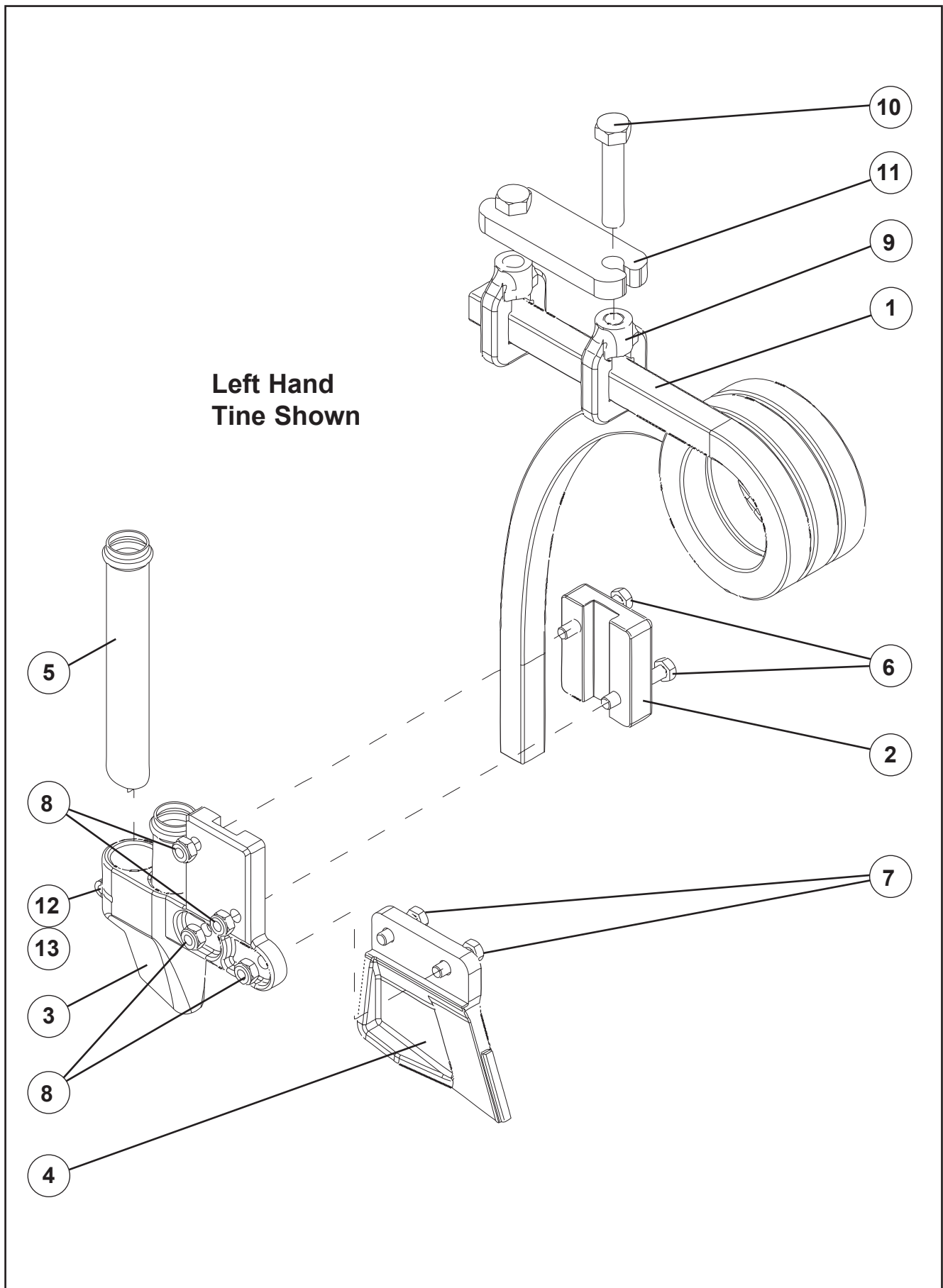

'Renovator Classic' Tine and Boot Assembly

| ITEM | PART No. | DESCRIPTION | QTY |
|------|----------|---|---------|
| 1 | 21413 | LH Coil Tine | 10 |
| 1 | 21414 | RH Coil Tine | 9 |
| 2 | 26848 | LH Inverted Tee Clamp | 19 |
| 3 | 25615 | RH Inverted Tee Clamp | 19 |
| 4 | 26849 | Cast Inverted Tee Point | 19 |
| 5 | 25608 | Fertilizer Tube, Standard (dual box) | 19 |
| 6 | 45010 | M10 x 65 Bolt, Class 8.8 | 38 |
| 7 | 45003 | M10 x 30 Bolt, Class 8.8 | 38 |
| 8 | 45138 | M10 Nyloc Nut | 76 |
| 9 | 21691 | Tine Clamp Casting | 38 |
| 10 | 45466 | M16 x 80 (4.6) Zinc Plated Bolt | 38 |
| 11 | 21690 | 75 x 75 RHS Clamp Plate | 19 |
| 12 | 45413 | M8 x 35 Bolt (dual box) | 19 |
| 13 | 45137 | M8 Nyloc Nut (dual box) | 19 |
| 14 | 43691 | Feed Hose 38mm | per mtr |
| 15 | 43500 | Cray Clip 47-49mm (fitted to top of hose not shown) | 19 |

'Renovator Classic' Drive Chains Dual Box

| ITEM | PART No. | DESCRIPTION | QTY |
|------|---------------|--|-----|
| 1 | 25724 | 13 T Sprocket 1/2" P x 20mm Bore | 1 |
| 2 | 22466 | 1/2" BS Chain x 55 Links (Transfer Shaft to Gearbox input) | 1 |
| 3 | 22537 | 25 T Sprocket 1/2" P x 20mm Bore | 2 |
| 4 | 22044 | 15 T Sprocket 1/2" P x 20mm Bore | 2 |
| 5 | 26350 | 13T/21T Change Sprocket | 1 |
| 6 | 25780 | 1/2" BS Chain x 47 Links (Gearbox to Boxshaft) | 2 |
| 7 | 25742 | 38 T Sprocket 1/2" P x 25mm Bore | 1 |
| 8 | 26352 | 13T/21T Crank Sprocket | 1 |
| 9 | 24103 | 1/2" BS Chain x 61 Links (Jockey Wheel Drive) | 1 |
| 10 | 22294 | Sprocket Key (6 x 6 x 25) | 8 |
| 11 | 45180 | M8 x 10 Socket Head Grub Screw | 14 |
| 12 | 45181 | M8 x 12 Socket Head Grub Screw | 2 |
| 13 | 43388 | 1/2" Pitch Joining Link | 4 |
| 14 | Refer page 54 | Front Chain Tensioner Box Shaft | 1 |
| 15 | Refer page 52 | Chain Tensioner Transfer Drive | 1 |
| 16 | Refer page 54 | Rear Chain Tensioner Box Shaft | 1 |
| 17 | Refer page 53 | Chain Tensioner Jockey Wheel Drive | 1 |

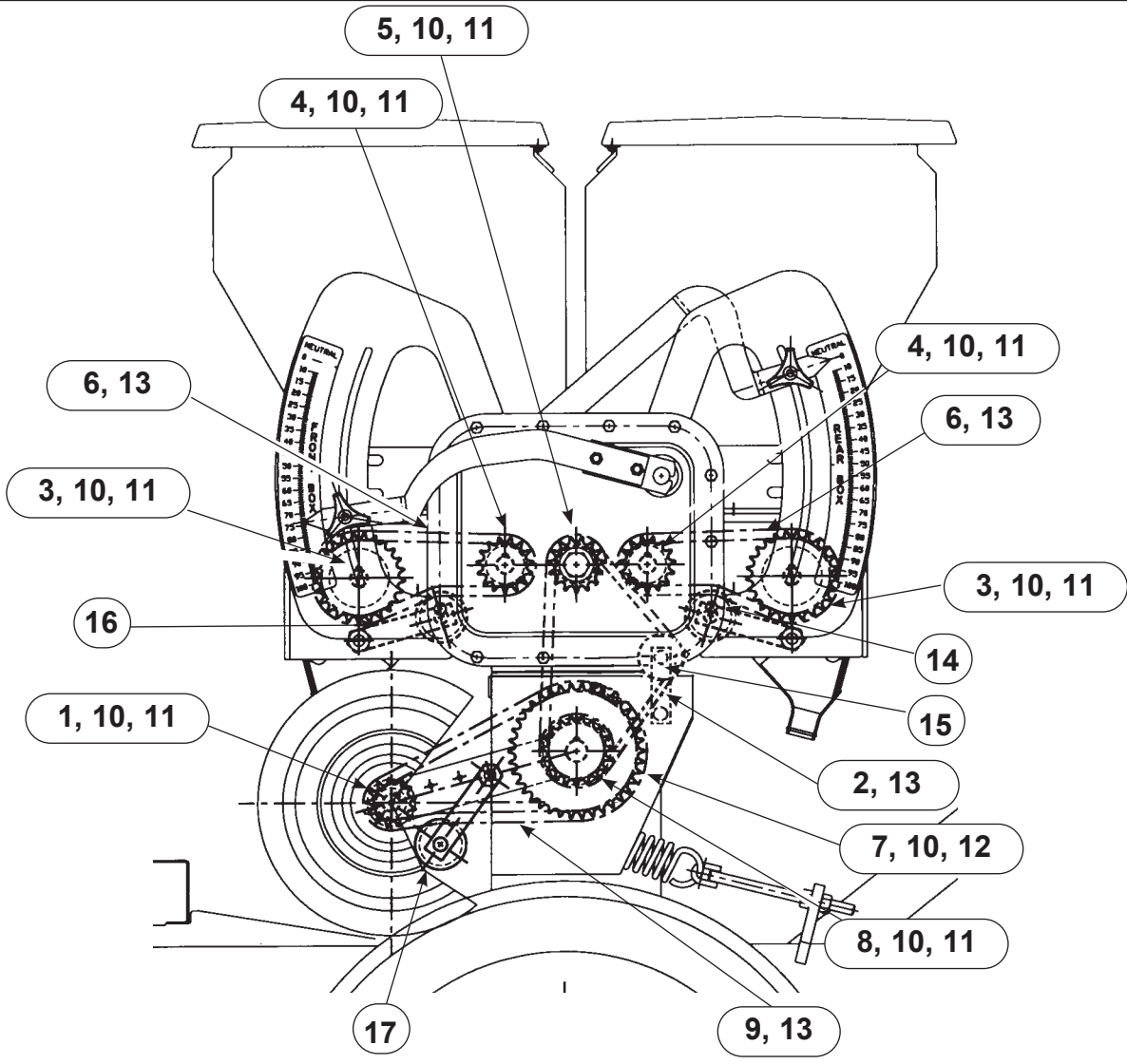

'Renovator Classic' Box Shaft Chain Tensioners

| ITEM | PART No. | DESCRIPTION | QTY |
|------|----------|------------------------|-----|
| 1 | 22535 | Nylon Roller | 2 |
| 2 | 22480 | Arm Assembly, RH | 2 |
| 3 | 22522 | Torsion Spring, LH | 1 |
| 4 | 22523 | Torsion Spring, RH | 1 |
| 5 | 23376 | Chain Tensioner Anchor | 2 |
| 6 | 45132 | M16 Hex Nut | 2 |
| 7 | 45462 | M16 x 60 Bolt | 2 |

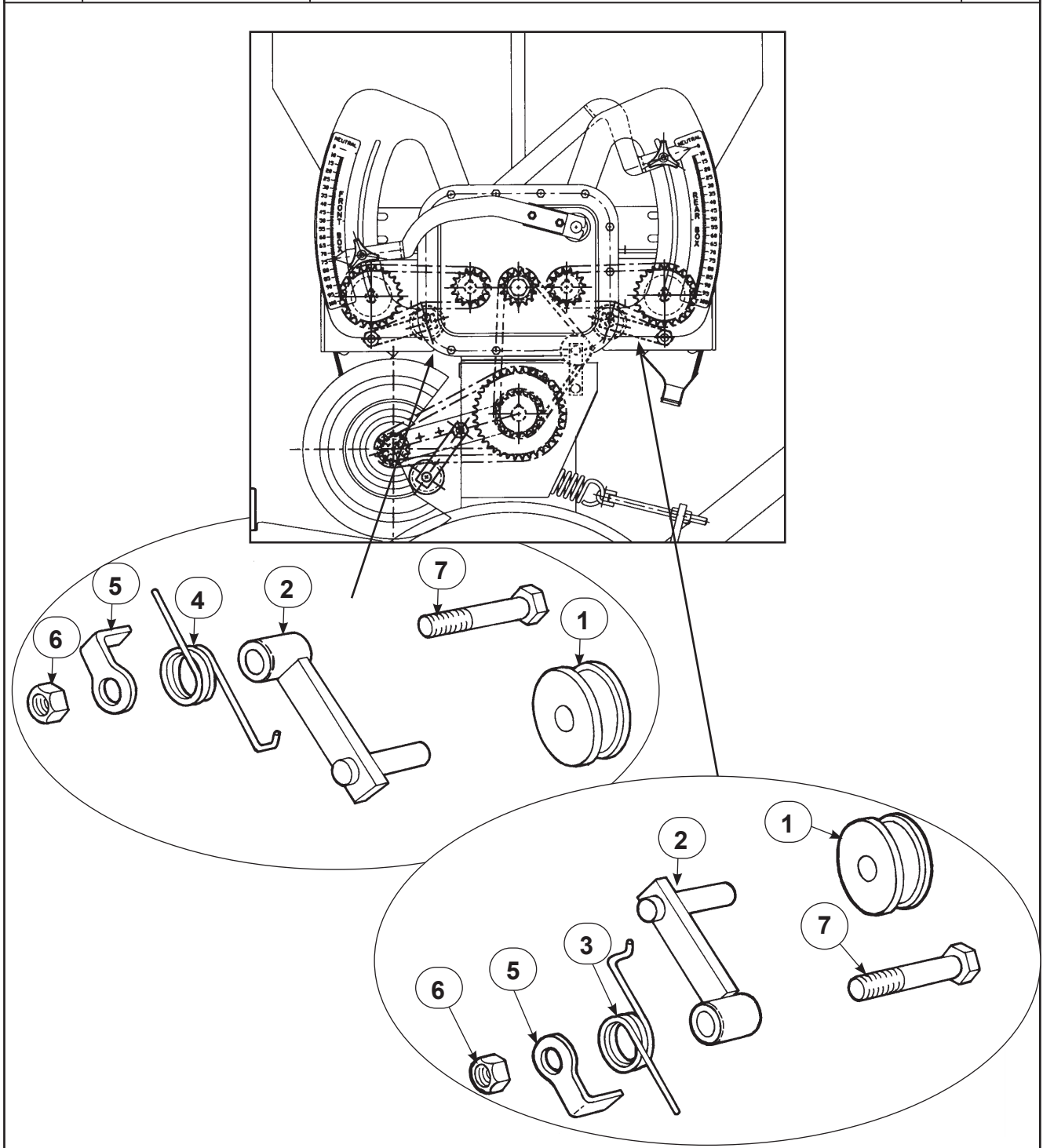

'Renovator Classic' Transfer Drive Chain Tensioners

| ITEM | PART No. | DESCRIPTION | QTY |
|------|----------|--------------------------------|-----|
| 1 | 22535 | Nylon Roller | 1 |
| 2 | 25984 | Arm Assembly, RH, 60 Extension | 1 |
| 3 | 22523 | Torsion Spring, RH | 1 |
| 4 | 45132 | M16 Hex Nut | 1 |
| 5 | 45461 | M16 x 55 Bolt (Dual Box) | 1 |

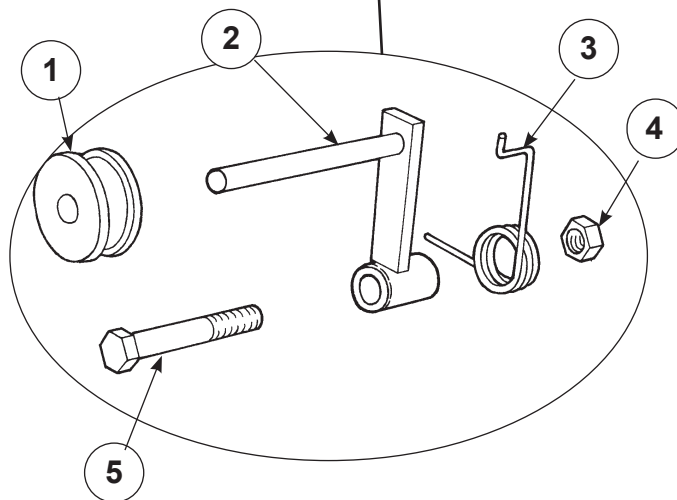
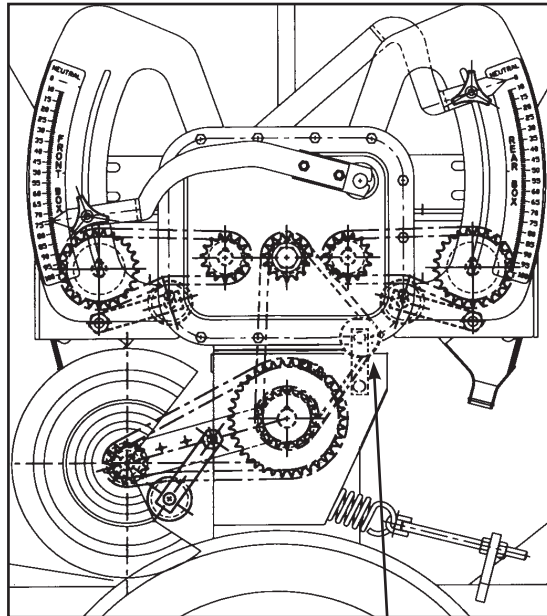

'Renovator Classic' Jockey Drive Chain Tensioners

| ITEM | PART No. | DESCRIPTION | QTY |
|------|----------|------------------------|-----|
| 1 | 22535 | Nylon Roller | 1 |
| 2 | 23373 | Short Arm Assembly, LH | 1 |
| 3 | 22523 | Torsion Spring, RH | 1 |
| 4 | 23376 | Chain Tensioner Anchor | 1 |
| 5 | 45119 | M16 Half Nut | 1 |
| 6 | 45462 | M16 x 60 Bolt | 1 |

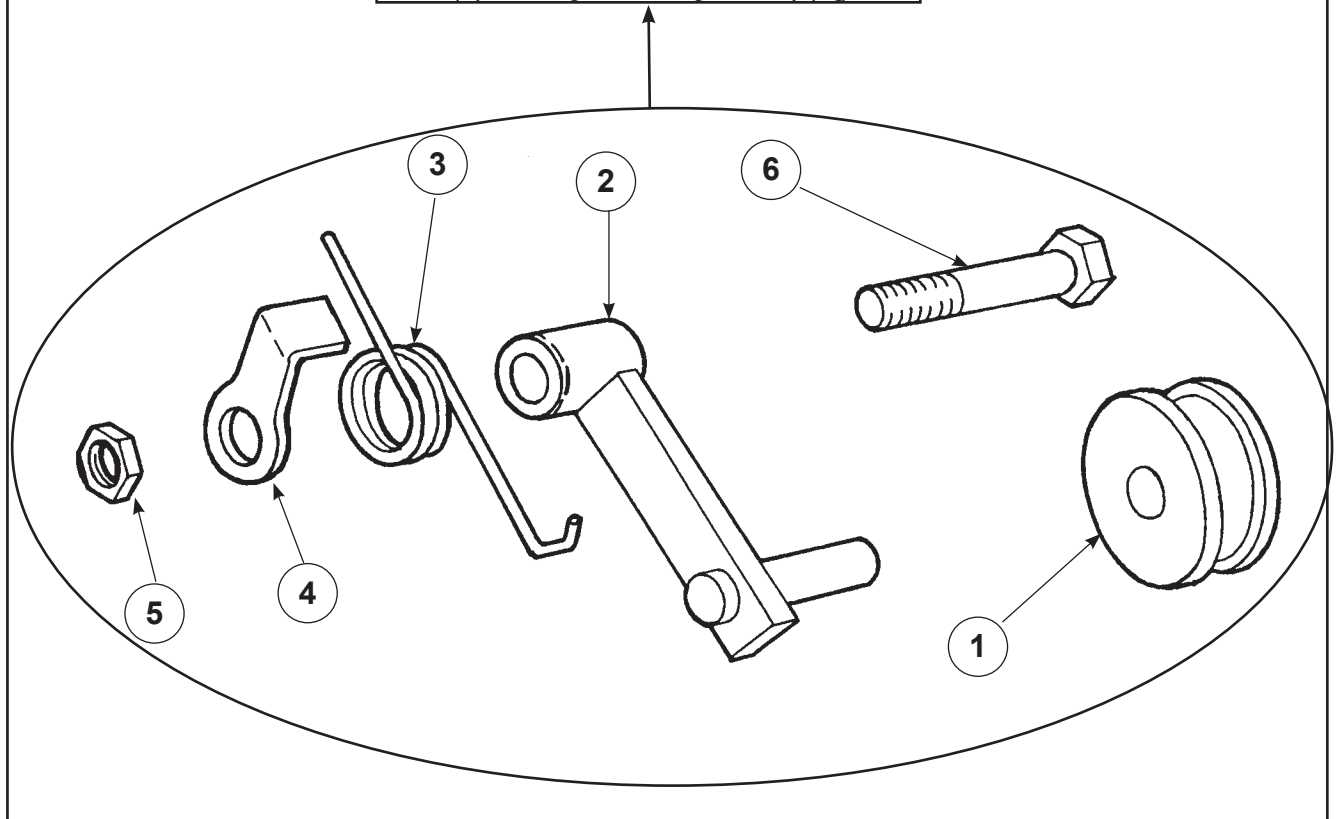
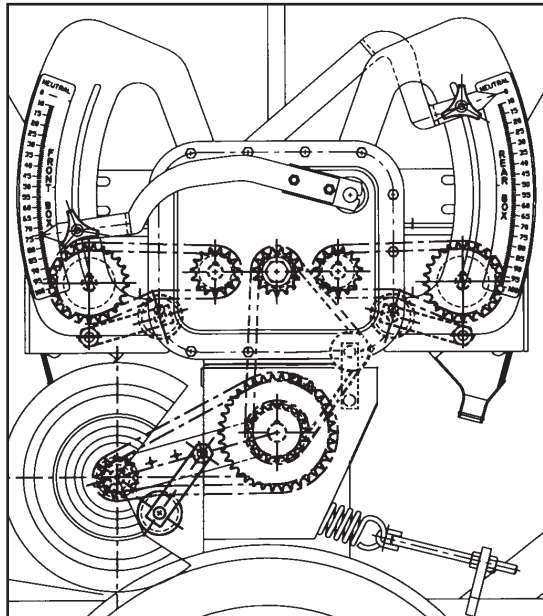

'Renovator Classic' Seed Box Drive Shafts

| ITEM | PART No. | DESCRIPTION | QTY |
|------|----------|---|-----|
| 1 | 22537 | Sprocket, 25T x 1/2" Pitch | 1 |
| 2 | 22294 | Key, Sprocket 6 x 6 x 25 | 1 |
| 3 | 25758 | Shaft, Box Drive | 1 |
| 4 | 43385 | "Y" Bearing | 2 |
| 5 | 43387 | Housing, Bearing, Press Steel (2 Flanges = 1 Housing) | 2 |
| 6 | 44992s | Set Screw, M8 x 20, Zinc Plate | 4 |
| 7 | 45137 | Nut, M8, Nylock | 4 |
| 8 | 45181 | Grubscrew, M8 x 12, Socket Head | 2 |
| 9 | 45151 | M8 Light Flat Washer | 8 |

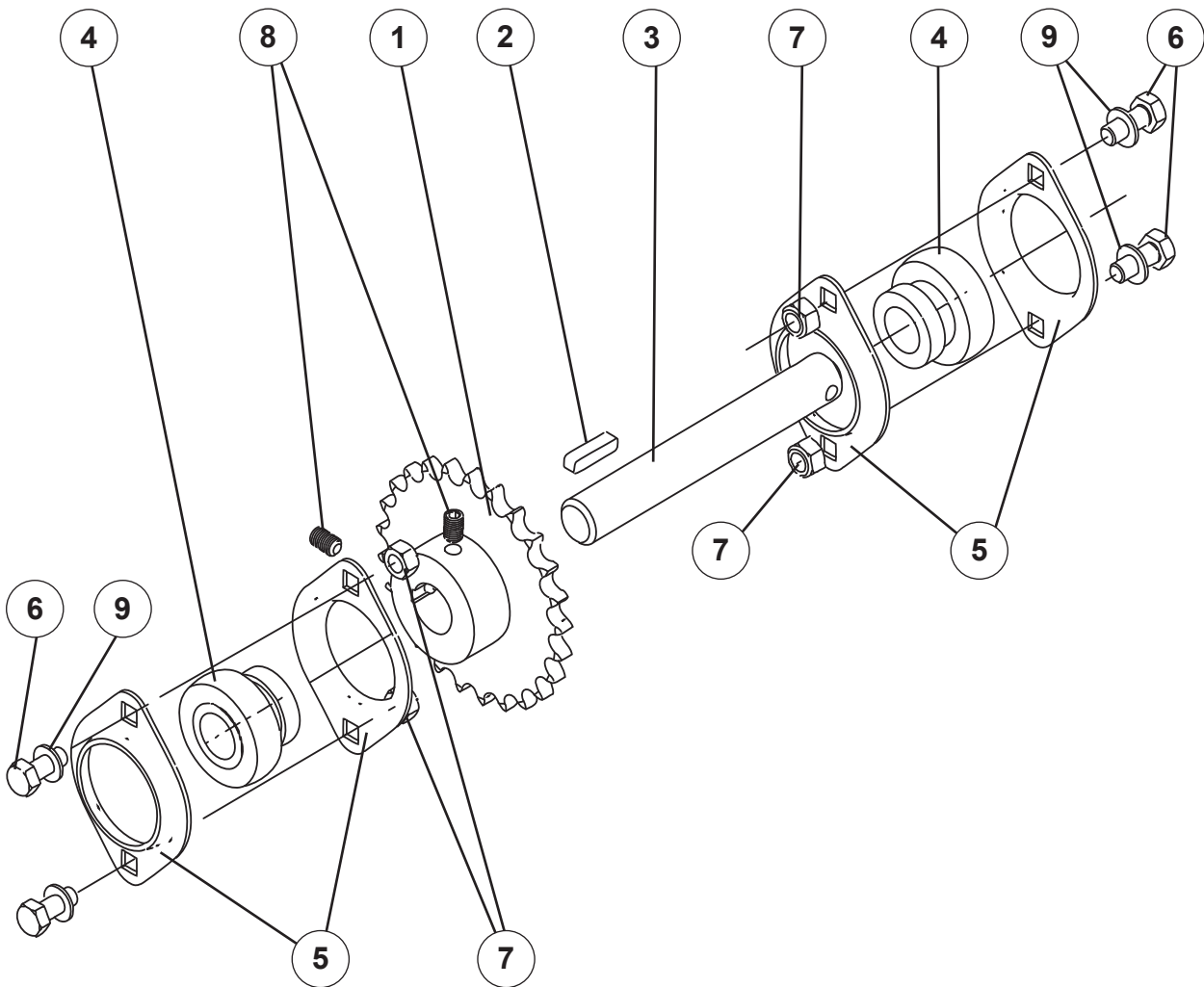

'Renovator Classic' Gearbox

| ITEM | PART No. | DESCRIPTION | QTY |
|------|----------|---|-----|
| 1 | 25756 | Gearbox Sub-Assembly | 1 |
| 2 | 22036 | Quadrant, Speed Adjusting | 2 |
| 3 | 25754 | Lever, Front, Speed Adjusting | 1 |
| 4 | 25755 | Lever, Rear, Speed Adjusting | 1 |
| 5 | 43366 | Tri-Knob, M8, Tapped Centre | 2 |
| 6 | 47031 | Bolt, Coach, M8 x 40 Cup Head, Class 4.6, Zinc Plated | 2 |
| 7 | 45151 | Washer, Flat, M8, Light | 2 |
| 8 | 22041 | Label, Front Box Speed Indicator (black writing on yellow background) | 1 |
| 9 | 22042 | Label, Rear Box Speed Indicator (yellow writing on black background) | 1 |
| 10 | 44992s | Set Screw M8 x 20 Grade 8.8 Zinc Plate | 2 |
| 11 | 44993s | SetScrew M8 x 25 Grade 8.8 Zinc Plate | 6 |
| 12 | 45157 | Washer, Flat, M8, Heavy Duty, Zinc Plate | 2 |
| 13 | 45137 | Nut, M8 Nyloc | 8 |
| 14 | 25762 | Gearbox Final Assembly (Includes items 1 to 13) | 1 |
| 15 | 26359 | 13T/21T 1/2"P Change Sprocket (not illustrated) | 1 |
| 16 | 22294 | Sprocket Key (not illustrated) | 1 |
| 17 | 45180 | Grub Screw, M8 x 10 Socket Head (not illustrated) | 2 |
| 18 | 43356 | 1/2" Bsp Sight Gauge | 1 |

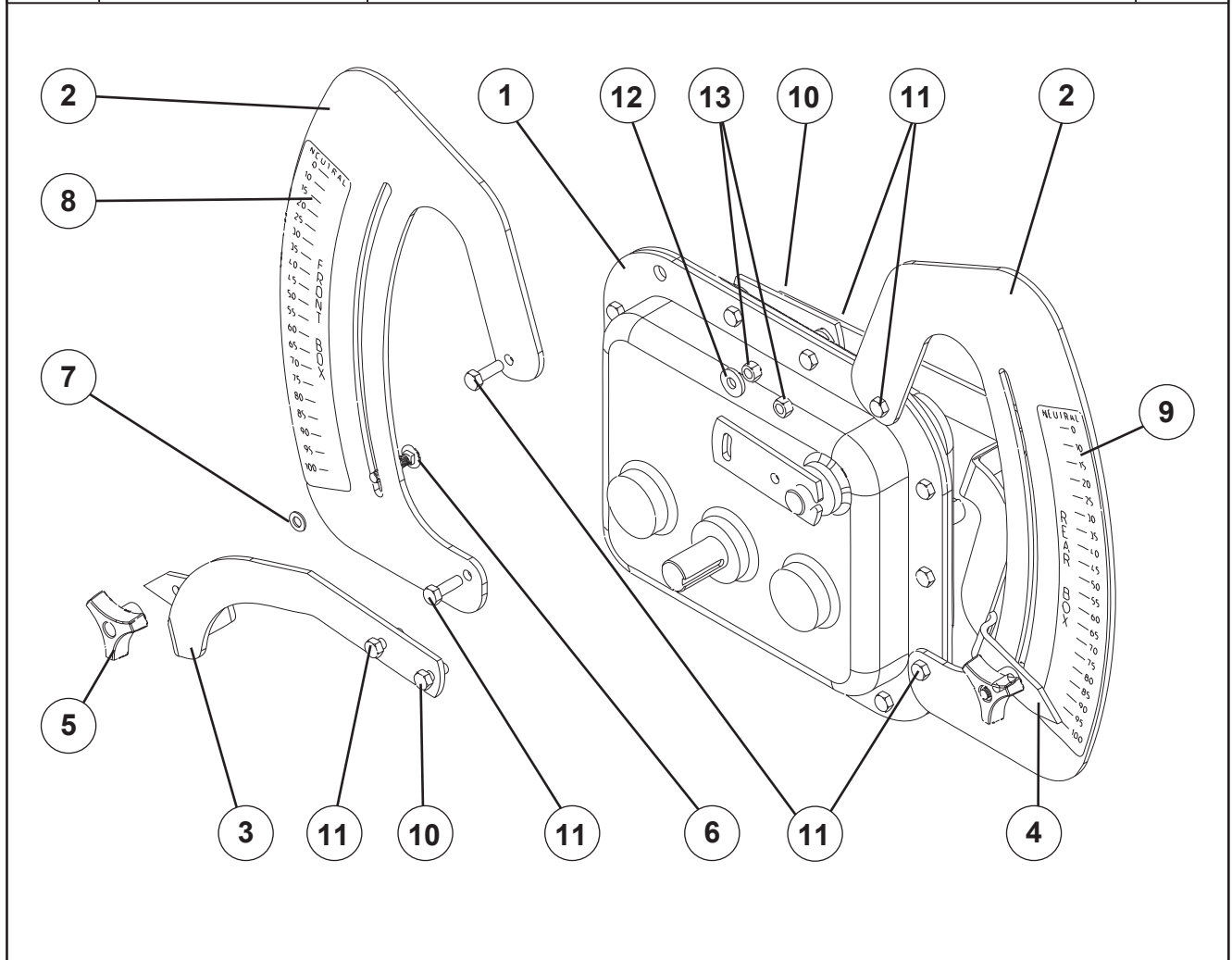

‘Renovator Classic’ Jockey Wheel Drive

| ITEM | PART No. | DESCRIPTION | QTY |
|------|----------|--|-----|
| 1 | 25742 | 38T 1/2" P (25mm Bore) Sprocket | 1 |
| 2 | 26352 | 13T/21T 1/2"P Crank Sprocket | 1 |
| 3 | 25724 | 13T 1/2" P (20mm Bore) Sprocket | 1 |
| 4 | 22294 | 6 x 6 x 25 Sprocket Key | 3 |
| 5 | 26569 | Drive Pedestal Shaft, Transfer | 1 |
| 6 | 25744 | Jockey Wheel and Axle Assembly | 1 |
| 7 | 43036 | Drive Pedestal Transfer Shaft Bearing | 2 |
| 8 | 17127 | Jockey Wheel Axle Bearing | 2 |
| 9 | 43386 | "Y" Bearing | 2 |
| 10 | 30359 | 3 Bolt Bearing Housing, PF52, (2 Flanges = 1 Housing) | 2 |
| 11 | 25726 | Jockey Drive Axle Spacer (where fitted) | 1 |
| 12 | 25725 | Jockey Arm Pivot Spacer | 2 |
| 13 | 25739 | Jockey Axle Inner Spacer | 1 |
| 14 | 25727 | Jockey Axle Outer Spacer (Loctite in place when fitted) | 1 |
| 15 | 25729 | Jockey Arm Pivot Outer Spacer (Loctite in place when fitted) | 1 |
| 16 | 25735 | Jockey Wheel Arm | 1 |
| 17 | 25746 | Jockey Drive Swing Guard | 1 |
| 18 | 45401S | M6 x 16, Z/P Set Screw | 2 |
| 19 | 45164 | M6, Z/P Spring Washer | 2 |
| 20 | 45156 | M6, H/D Z/P Flat Washer | 2 |
| 21 | 45180 | M8 x 10 Socket Head Grubscrew | 4 |
| 22 | 45181 | M8 x 12 Socket Head Grubscrew | 2 |
| 23 | 45411S | Set Screw, M8 x 20 Class 4.6, Zinc Plated | 6 |
| 24 | 45137 | M8, Nyloc Nut | 6 |
| 25 | 47625 | M16 Bellevilles Disc Washer | 1 |
| 26 | 45140 | M16 Nyloc Nut | 1 |
| 27 | 45163 | M24 H/D Flat Washer Z/P | 1 |
| 28 | 74667 | Drive Shaft Extension- Non Hex | 1 |
| 29 | 72951 | Prox Trigger | 1 |
| 30 | 48036 | Dia. 14-27mm Hose Clip Stainless | 1 |
| 31 | 72913 | Sensor Mount Bracket | 1 |
| 32 | 45001s | M10 x 20 Class 8.8, Z/P Set Screw | 1 |
| 33 | 45152 | M10 Light Flat Washer | 1 |
| 34 | 45138 | M10 Nyloc Nut | 1 |
| 35 | 11652 | Proximity Sensor | 1 |

'Renovator Classic' Dual Seedbox Assembly

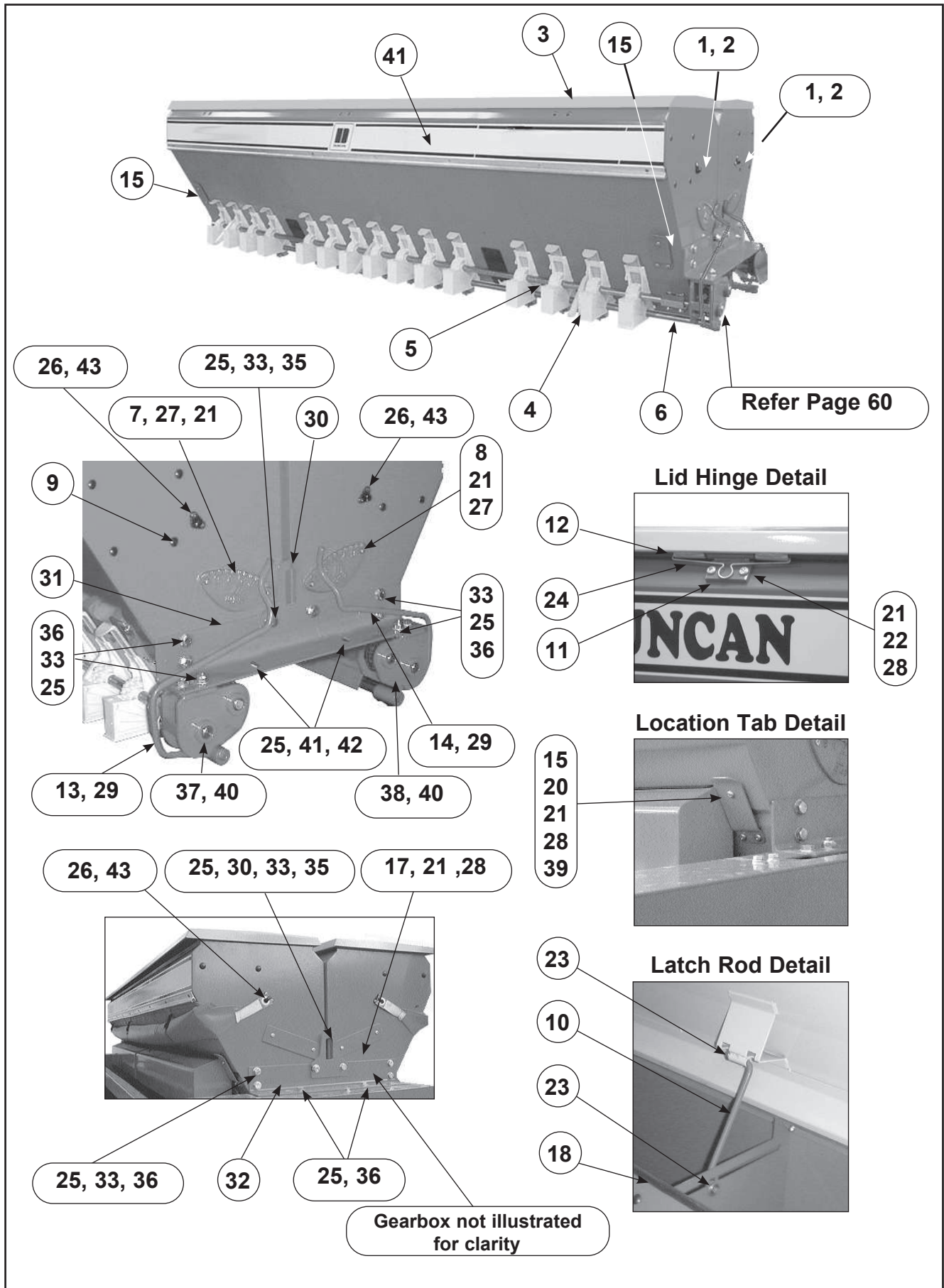

'Renovator Classic' Dual Seedbox Assembly

| ITEM | PART No. | DESCRIPTION | QTY |
|------|---------------|---|-----|
| 1 | 26642 | Combi Box Only (No Lid) | 1 |
| 2 | 26646 | Combi Box with Lid | 2 |
| 3 | 25785 | Box Lid Only | 2 |
| 4 | Refer page 62 | Seeder Assembly | 38 |
| 5 | 25812 | Box Shaft (20mm) | 2 |
| 6 | 22530 | Flap Shaft (18mm) | 2 |
| 7 | 10143 | Front Box Quadrant Plate | 1 |
| 8 | 10158 | Rear Box Reverse Quadrant Plate | 1 |
| 9 | 14442 | Rubber Body Plug | 28 |
| 10 | 22487 | Latch Rod Assembly | 2 |
| 11 | 22490 | Hinge Assembly | 6 |
| 12 | 22491 | Hinge Pin | 6 |
| 13 | 25708 | Front Flap Handle Assembly | 1 |
| 14 | 25709 | Rear Flap Handle Assembly | 1 |
| 15 | 22568 | Location Tab (Calibration Tray) | 4 |
| 16 | 47615 | M6 x 40 Bolt S/Steel | 8 |
| 17 | 22855 | Agitator Access Blanking Plate | 2 |
| 18 | 43373 | Black Edge Trim 2.5m | 2 |
| 19 | 22419 | Box Shaft Connecting Sleeve | 4 |
| 20 | 45122 | M6 Class 8.8 Zinc Plated Hex Nut | 4 |
| 21 | 45136 | M6 Nylock Nut | 36 |
| 22 | 45150 | M6 Zinc Plated Light Flat Washer | 12 |
| 23 | 45368 | M10 Starlock Fixing Washer | 4 |
| 24 | 27599 | Hinge Pin Spring Clip | 6 |
| 25 | 45139 | M12 Nylock Nut | 24 |
| 26 | 45702 | 4.8 x 9.5 Monel Pop Rivet | 8 |
| 27 | 45758 | M6 x 16 Zinc Plated Countersunk Posidrive Screw | 4 |
| 28 | 45908 | M6 x 16 Zinc Plated Pan Head Machine Screw | 20 |
| 29 | 45186 | M10 x 12 Socket Head Grubscrew | 4 |
| 30 | 22485P | Box Set Lifting Eye Profile | 2 |
| 31 | 25759 | Box Set Mounting Bracket LH | 1 |
| 32 | 25760 | Box Set Mounting Bracket RH | 1 |
| 33 | 45153 | M12 Zinc Plated Light Flat Washer | 32 |
| 35 | 45435S | M12 x 40 Set Screw | 4 |
| 36 | 45433S | M12 x 30 Set Screw | 12 |
| 37 | 22445 | Front Agitator Drive Assembly (Refer Page 62) | 1 |
| 38 | 22446 | Rear Agitator Drive Assembly (Refer Page 62) | 1 |
| 39 | 45907 | M6 x 12 Pan Head Pozi Drive Screw M/C | 12 |
| 40 | Refer page 61 | Agitator parts | 2 |
| 41 | 43737 | Renovator Classic Transfer | 2 |
| 41 | 45434 | M12 x 35 Bolt | 2 |
| 42 | 45159 | M12 H/D Flat Washer | 2 |
| 43 | 43430 | Lashing Hook | 4 |

'Renovator Classic' Agitator Drives

| ITEM | PART No. | DESCRIPTION | QTY |
|------|----------|--|-----|
| 1 | 22446 | Agitator Drive Rear Housing complete with internals | 1 |
| 2 | 22414 | Rear Housing only | 1 |
| 3 | 22445 | Agitator Drive Front Housing complete with internals | 1 |
| 4 | 22415 | Front Housing only | 1 |
| 5 | 22418 | 3/8" Pitch x 20mm Bore 21T Sprocket | 2 |
| 6 | 22422 | 3/8" Pitch x 20mm Bore 15T Sprocket | 2 |
| 7 | 22417 | 3/8" Pitch x 33 Link BS Chain | 2 |
| 8 | 43396 | 3/8" Pitch Joiner Link | 2 |
| 9 | 44968 | M8 x 60 Class 8.8 Zinc Plated Bolt | 2 |
| 10 | 44965 | M8 x 45 Class 8.8 Zinc Plated Bolt | 2 |
| 11 | 45137 | M8 Nylock Nut | 4 |
| 12 | 22425 | Agitator Shaft Extension | 2 |
| 13 | 22426 | Seed Shaft Extension | 2 |
| 14 | 43428 | Nylon Bush | 6 |
| 15 | 22416 | Agitator Drive Spacer | 2 |
| 16 | 22419 | Box Shaft Connecting Sleeve | 2 |
| 17 | 22420 | Agitator Shaft Joining Collar | 2 |
| 18 | 45180SS | M8 x 10 Stainless Steel Socket Head Grub Screw | 4 |
| 19 | 44956SS | M6 x 40 Bolt S/Steel | 4 |
| 20 | 45136SS | M6 Nyloc Nut S/Steel | 4 |
| 21 | 45150SS | M6 Light Flat Washer | 4 |

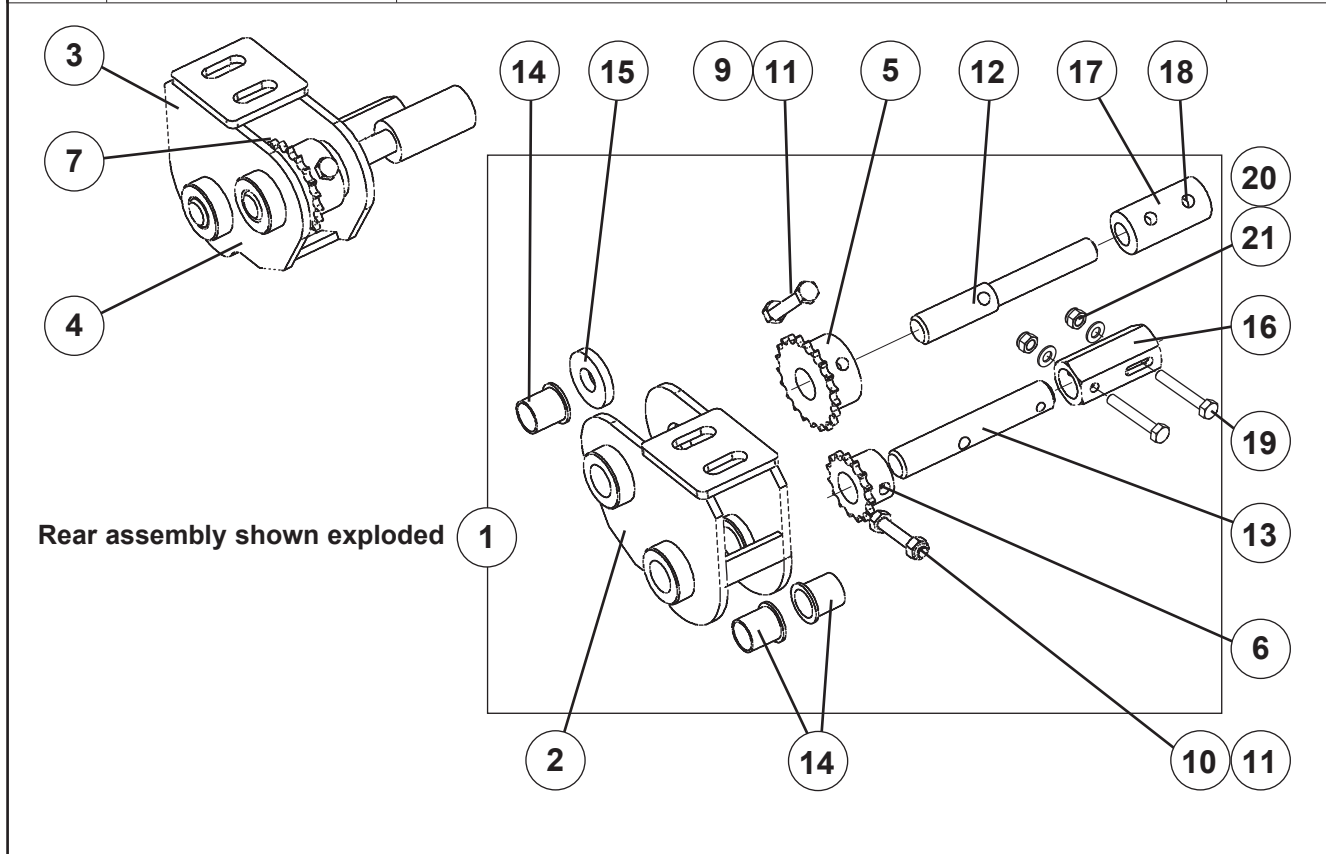

'Renovator Classic' Agitator Shaft Assembly

| ITEM | PART No. | DESCRIPTION | QTY |
|------|----------|--|-----|
| 1 | 62048 | Agitator Shaft Assembly | 1 |
| 2 | 22420 | 16mm Agitator Joining Collar | 2 |
| 3 | 22423 | Agitator Shaft Support RH (Short) | 2 |
| 4 | 22424 | Agitator Shaft Support LH (Long) | 2 |
| 5 | 22428 | Agitator Shaft Support Cap | 2 |
| 6 | 43442 | 5/8" Lurethane Wiper Seal | 4 |
| 7 | 45185SS | M10 x 10 Stainless Steel Socket Head Grubscrew | 4 |
| 8 | 45410SSS | M8 x 16 Grade 316 Stainless Steel Set Screw | 4 |
| 9 | 45137SS | M8 Grade 316 Stainless Steel Nylock Nut | 4 |
| 10 | 47600 | M30 ISO Fine Zinc Plated Hex Lock Nut | 4 |

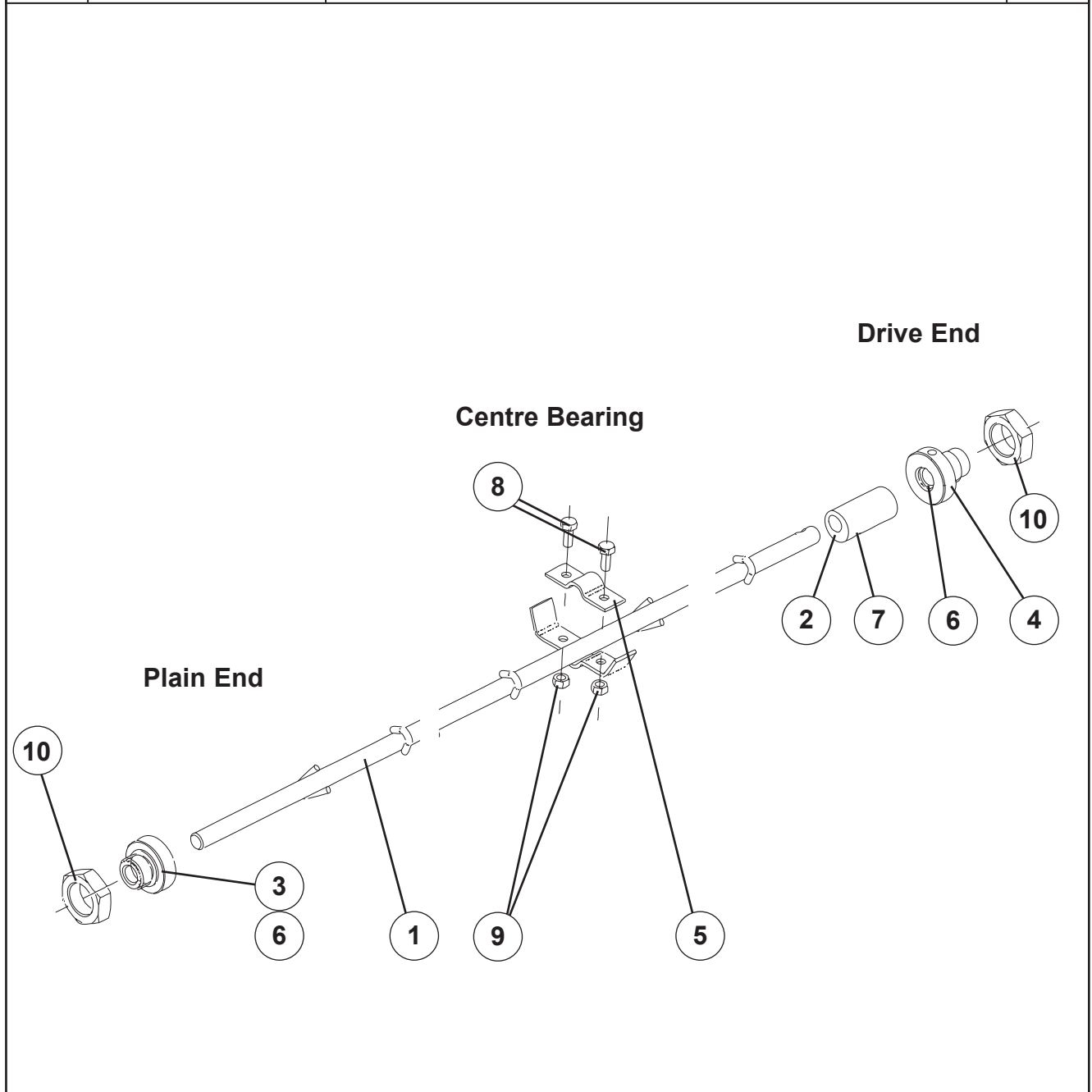

'Renovator Classic' Seeder Mechanism

| ITEM | PART No. | DESCRIPTION | QTY |
|------|----------|--|-----------|
| 1 | 43375 | Metering Housing | 1 per run |
| 2 | 43376 | Shutter Slide | 1 per run |
| 3 | 43377 | Seed Metering Wheel Assembly (Includes item 4) | 1 per run |
| 4 | 43374 | Fine Seed Wheel (For Spares Ordering Only) | - |
| 5 | 43378 | Bottom Flap & Bolt Assembly | 1 per run |
| 6 | 22550 | Seeder Extension Funnel | 1 per run |
| 7 | 22551 | Seed Diverter | 1 per run |
| 8 | 22548 | Spring Clip, S/S | 1 per run |
| 9 | 43379 | Seed Shaft Guide Bearing | 6 |
| 10 | 43380 | Guide Bearing Tension Spring | 6 |
| 11 | 43382 | Metering Wheel Clutch Hook | 1 |
| 12 | 43383 | Seed Rate Disc Calculator | 1 |
| 13 | 43362 | Fine Seed Wheel Brush (Optional Extra) | - |

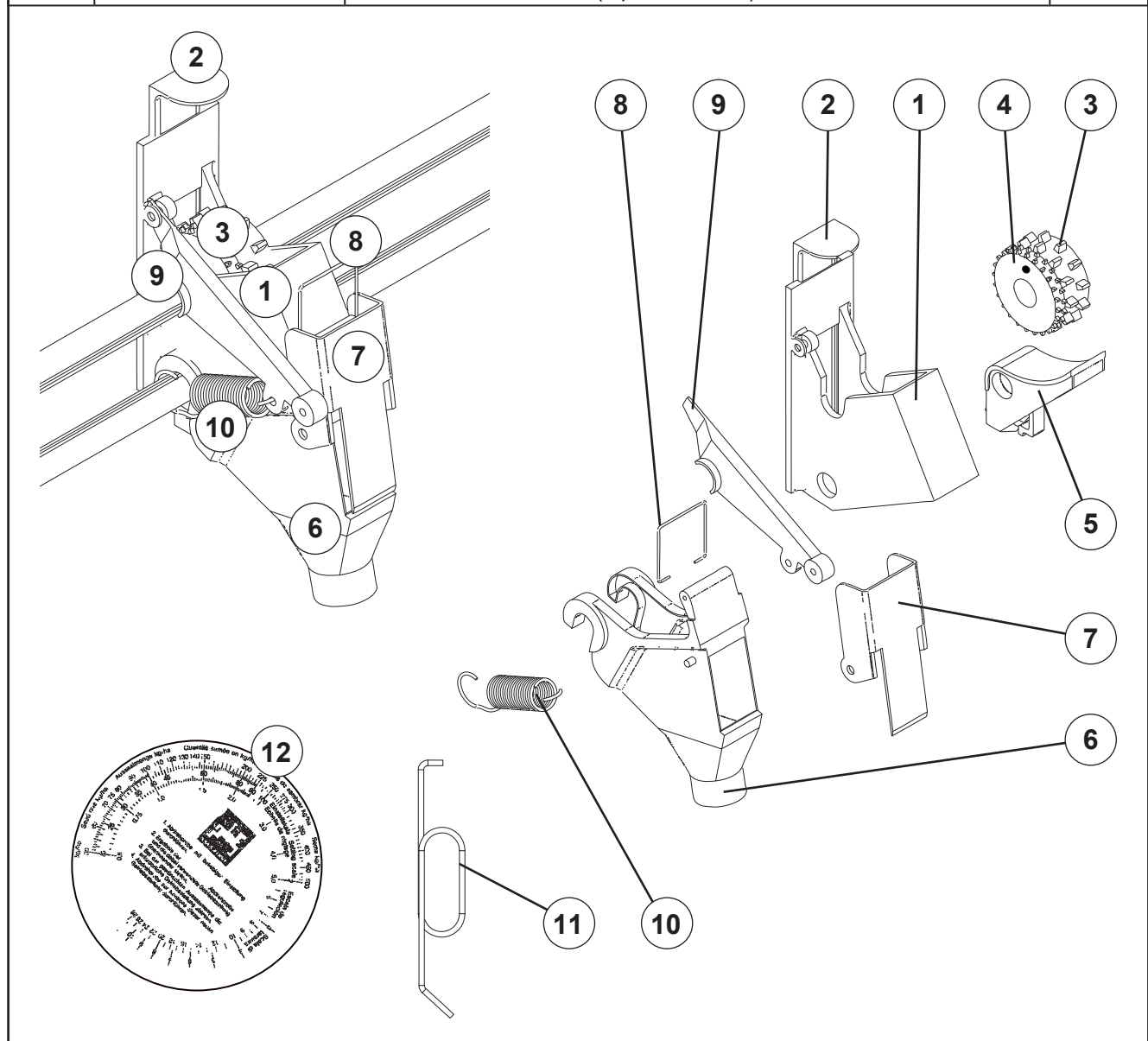

'Renovator Classic' (Optional) Hectaremeter Kit

| ITEM | PART No. | DESCRIPTION | QTY |
|--|----------|----------------------------------|-----|
| KIT | 44571K | Contains the following: | |
| 1 | 44572 | Jackal Basic Speed & Area Meter | 1 |
| 2 | 44573 | Owner's Manual Jackal | 1 |
| 3 | 44028 | Window Mount AH-407 | 1 |
| 4 | 48027 | 7.5m Cable (3 way) | 1 |
| 5 | 11652 | Prox Sensor | 1 |
| 6 | 48177 | Cable S/Assy (1 x 3way + power) | 1 |
| <i>Individual items from 48177 listed below:</i> | | | |
| 7 | 44029 | Power Cable | 1 |
| 8 | 44146 | 11 way Terminal Block P321 Green | 1 |
| 9 | 44567 | 11 way Terminal Block P322 Grey | 1 |
| 10 | 48178 | 3 Way Short Cable | 1 |

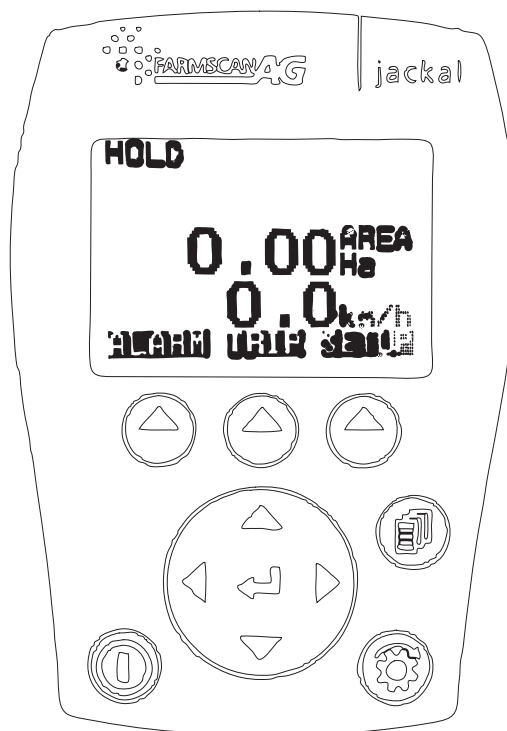

'Renovator Classic' (Optional) Disc Opener

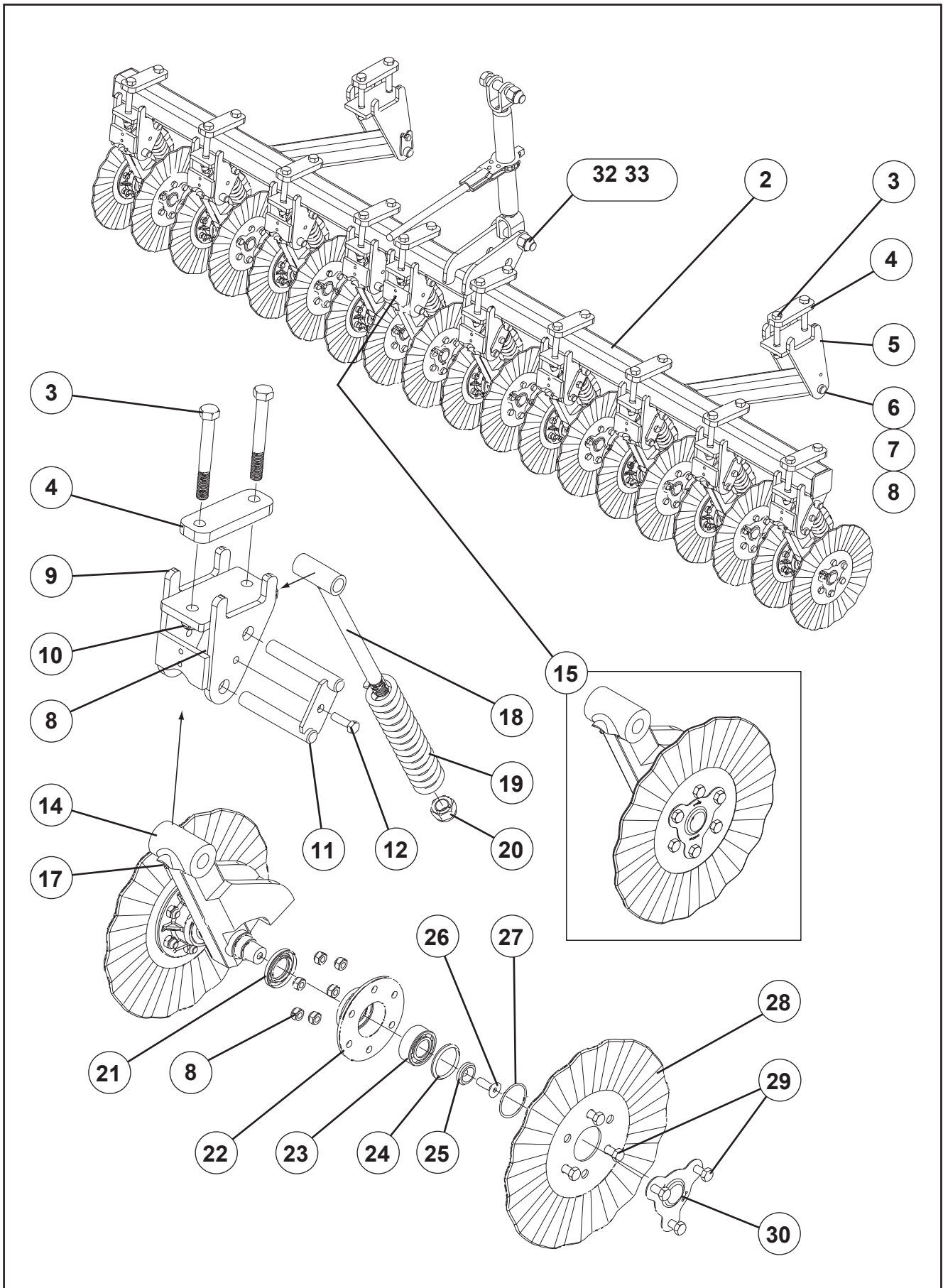

'Renovator Classic' (Optional) Disc Opener

| ITEM | PART No. | DESCRIPTION | QTY |
|------|----------|---------------------------------------|-----|
| 1 | C/RCDO | Disc Opener Complete | 1 |
| 2 | 62040 | Disc Opener Frame | 1 |
| 3 | 45051 | M16 X 130 Class 8.8 Bolt | 24 |
| 4 | 21690 | Clamp Plate | 12 |
| 5 | 25562 | Disc Opener Frame Support Welded Assy | 2 |
| 6 | 21245 | Pivot Pin Assy | 2 |
| 7 | 45001s | M10 x 20 Class 8.8 Set Screw | 2 |
| 8 | 45138 | M10 Nyloc Nut | 108 |
| 9 | 60460 | Mounting Bracket | 10 |
| 10 | 45140 | M16 Nyloc Nut | 24 |
| 11 | 21244 | Double Pivot Pin Assembly | 10 |
| 12 | 45004 | M10 x 35 Class 8.8 Bolt | 10 |
| 13 | 60455 | Double Disc Assembly | 9 |
| 14 | 60459 | Double Axle Arm Welded Assy | 9 |
| 15 | 60452 | Single Disc Assembly LH | 1 |
| 16 | 60456 | Single Axle Arm Welded Assy | 1 |
| 17 | 43118 | Grease Nipple Straight | 10 |
| 18 | 26310 | T Bolt Spring Rod | 10 |
| 19 | 60294 | Disc Opener Spring | 10 |
| 20 | 45141 | M20 Nyloc Nut | 10 |
| 21 | 45650 | Seal | 19 |
| 22 | 60466 | Housing | 19 |
| 23 | 45652 | Bearing | 19 |
| 24 | 60469 | Bearing Retainer (Outer Race) | 19 |
| 25 | 60444 | Bearing Retainer (Inner Race) | 19 |
| 26 | 45662 | M10 x 30 CSK Screw | 19 |
| 27 | 45653 | O Ring Seal | 19 |
| 28 | 22035 | Fluted Disc 318mm Dia. | 19 |
| 29 | 45002s | M10 x 25 Class 8.8 Set Screw | 114 |
| 30 | 60468 | Cover Plate Stainless Steel | 19 |
| 31 | 43395 | H/D Ratchet Turnbuckle | 1 |
| 32 | 47254 | Bolt 1" UNF x 5" HT | 2 |
| 33 | 47552 | 1" UNF Nyloc Nut | 4 |

'Renovator Classic' (Optional) Disc Opener

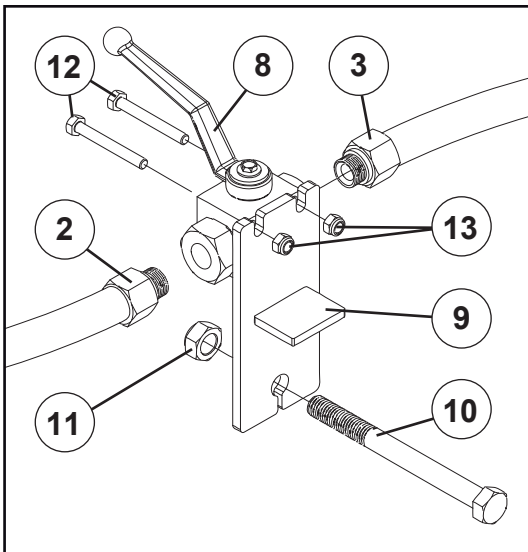
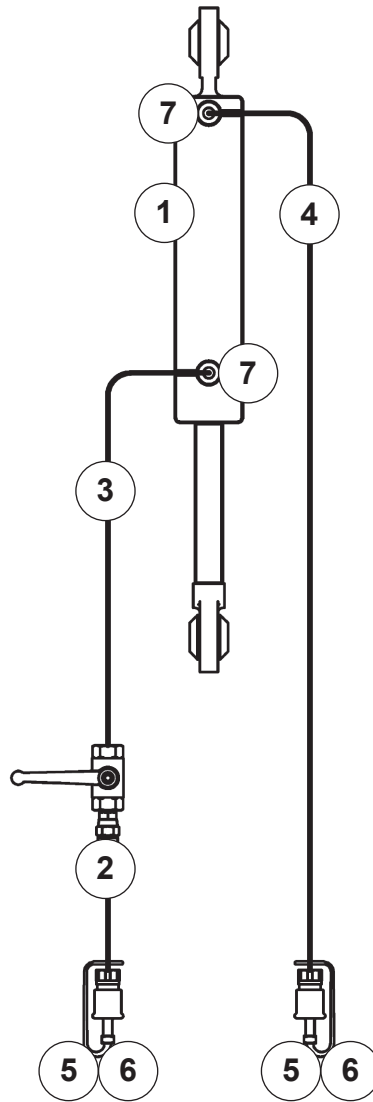
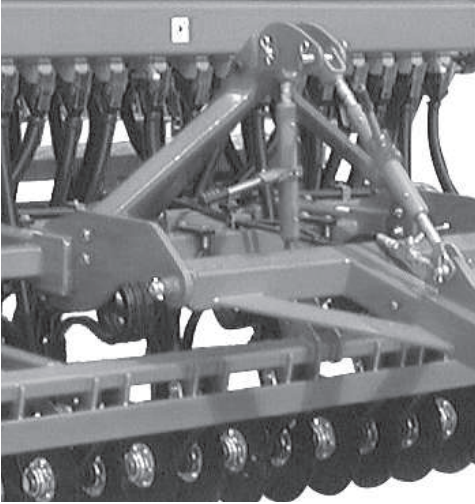

‘Renovator Classic’ (Optional) Disc Opener

| ITEM | PART No. | DESCRIPTION | QTY |
|------|----------|----------------------------------|-----|
| 1 | 45655 | Hydraulic Cylinder | 1 |
| 2 | 60874 | Hydraulic Hose 2.70m | 1 |
| 3 | 26695 | Hydraulic Hose 0.60m | 1 |
| 4 | 26696 | Hydraulic Hose 3.5m | 1 |
| 5 | 43147 | 1/2" BSP Quick Release Coupling | 2 |
| 6 | 43617 | Dust Cover | 2 |
| 7 | 43280 | 3/4" UNO to 3/8" BPSM Nipple | 2 |
| 8 | 43393 | 3/8" BSP S/S Ball Valve | 1 |
| 9 | 60856 | Hydraulic Valve Support Assembly | 1 |
| 10 | 45035 | M12 x 140 Grade 8.8 Bolt | 1 |
| 11 | 45139 | M12 Nyloc Nut | 1 |
| 12 | 44957 | M6 x 50 Bolt | 2 |
| 13 | 45136 | M6 Nyloc Nut | 2 |
| 14 | 47254 | 1.0 UNF X 5.0" HT Bolt | 2 |
| 15 | 47552 | 1.0"UNF Nyloc Nut | 2 |

NOTE: Items 1 to 13 may be ordered as a kit. Part number 60076K

'Renovator Classic' (Optional) Wiring & Lighting

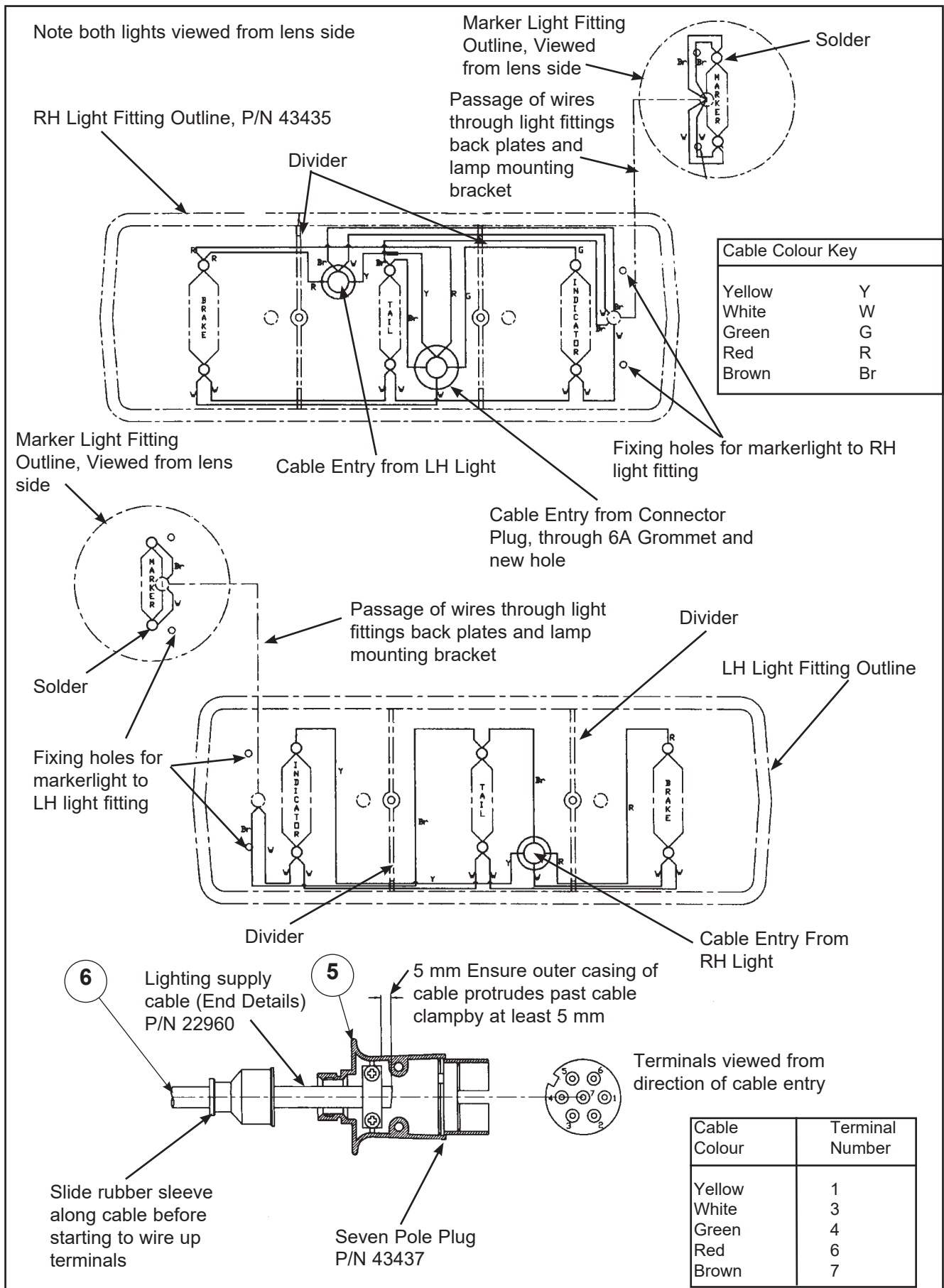

'Renovator Classic' (Optional) Wiring & Lighting

| ITEM | PART No. | DESCRIPTION | QTY |
|------|----------|--|-----|
| 1 | 25913K | Complete Lamp Kit, 15 Run | 1 |
| 2 | 25915K | Complete Lamp Kit, 19 Run | 1 |
| 3 | 24228 | Lamp Bracket Assembly L.H. | 1 |
| 4 | 24227 | Lamp Bracket Assembly R.H. | 1 |
| 5 | 43435 | Combination Rear Lamp | 2 |
| 6 | 43436 | Marker Lamp | 2 |
| 7 | 43438 | Flex, 5 Core Trailer (15 Run x 9.3m, 19 Run x 10.0m) | 1 |
| 8 | 43443 | Wire, Appliance, White 1mm x 1m | 1 |
| 9 | 43444 | Wire, Appliance, Brown 1mm x 1m | 1 |
| 10 | 45136 | Nut, Nyloc, M6 | 4 |
| 11 | 45137 | Nut, M8 Nylock | 4 |
| 12 | 45399 | Bolt, M8 x 30 Class 4.6 Zinc Plated | 4 |
| 13 | 45403S | Set Screw, M6 x 25 | 4 |
| 14 | 45860 | Screw, No. 12 x 3/4" Pan PZ Zinc Plated Self Tapping | 4 |
| 15 | | Bulb, 5W Festoon 15 x 44mm | 4 |
| 16 | | Bulb, 21W Festoon 15 x 44mm | 4 |

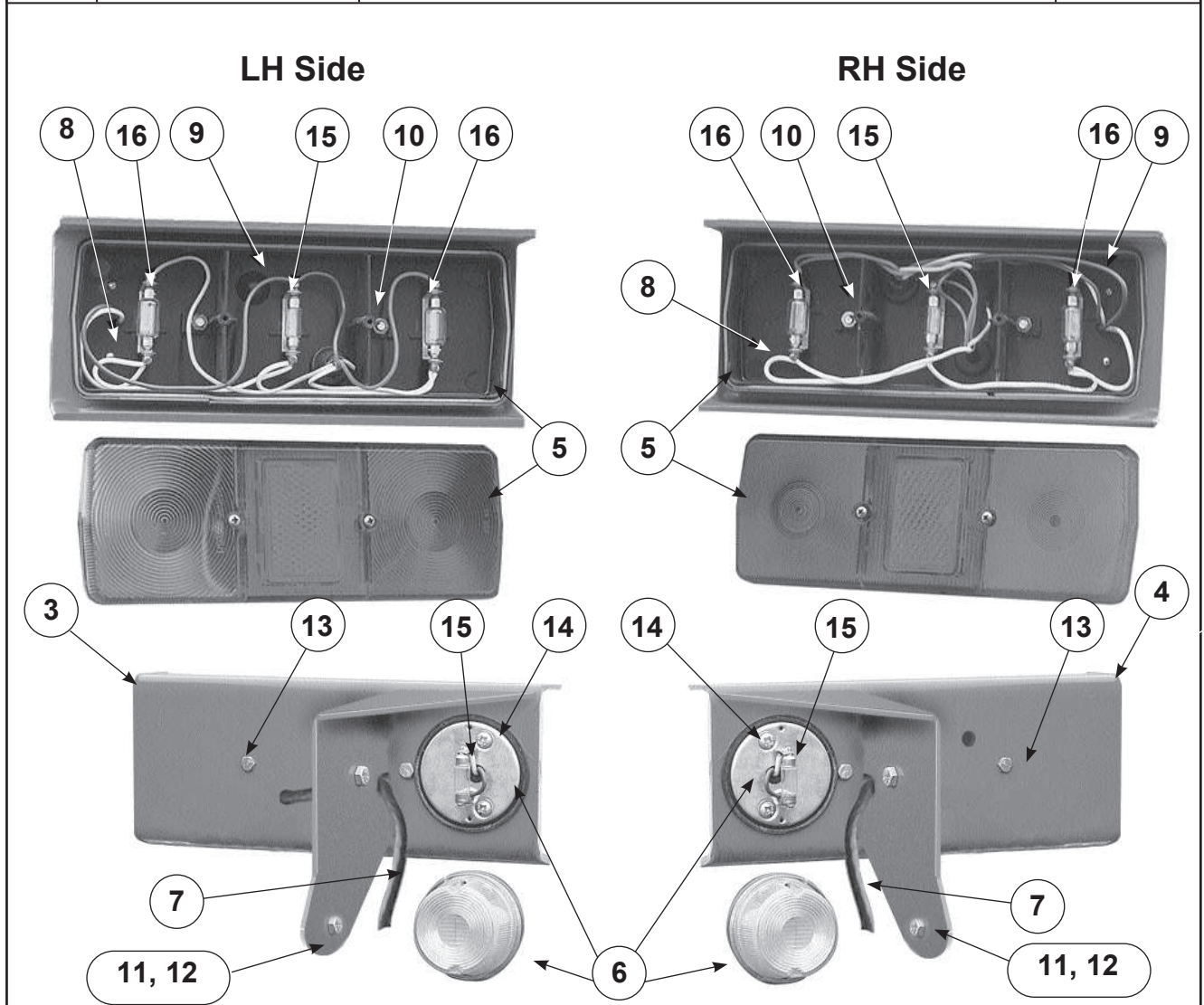

'Renovator Classic' Optional Extras

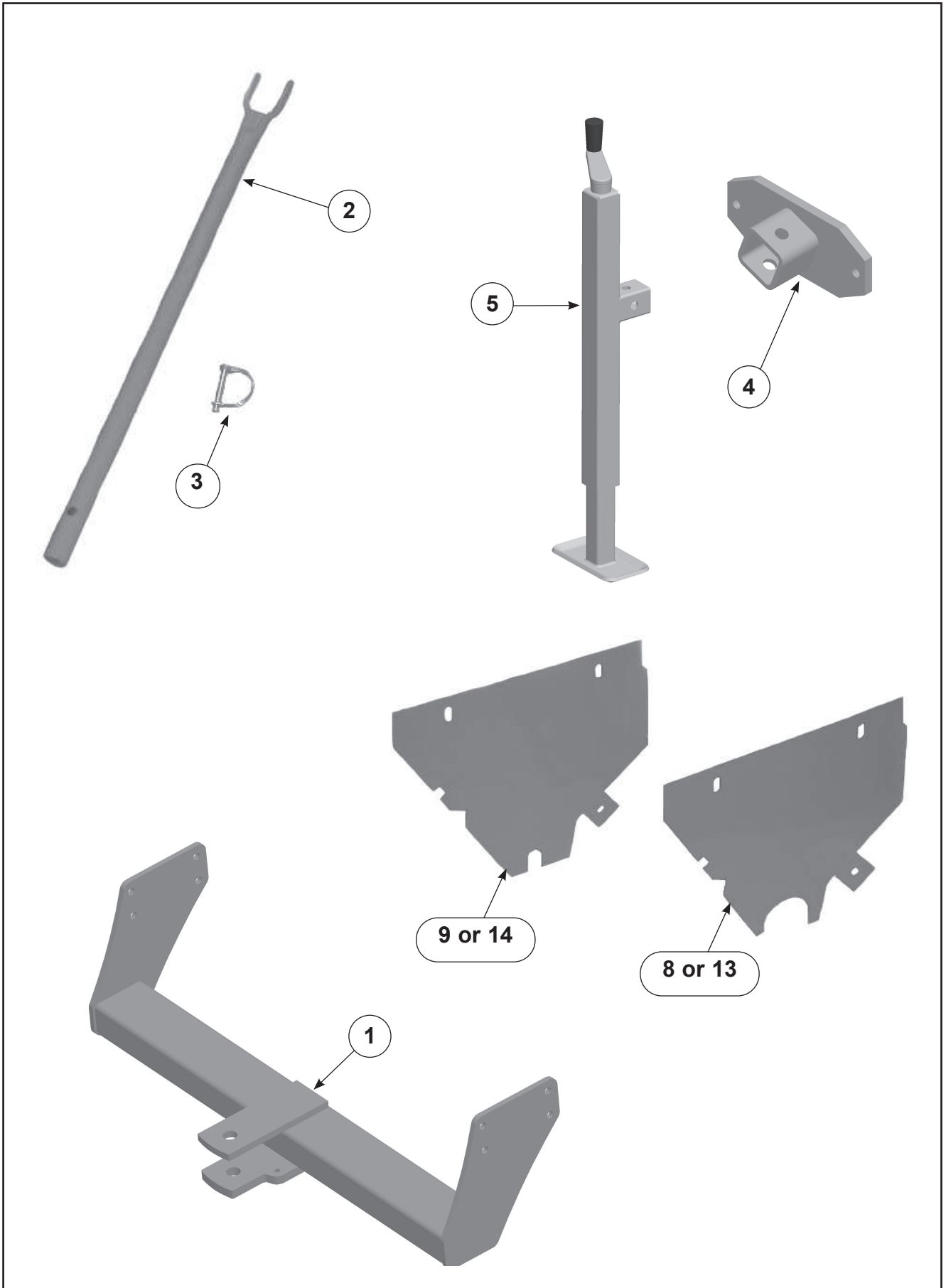

'Renovator Classic' Optional Extras

| ITEM | PART No. | DESCRIPTION | QTY |
|------|----------|---|-----------|
| 1 | 26795 | Rear Tow Hitch Assembly | 1 |
| | 26852k | Harrow Transport Kit (Items 2 to 3) | |
| 2 | 26003 | Harrow Transport Support Assembly | 4 |
| 3 | 19199 | Shaft Locking Pin | 4 |
| | 26850k | Jack Stand Kit (Items 4 to 7) | |
| 4 | 26809 | Jack Support Bracket | 1 |
| 5 | 31478 | Jack | 1 |
| 6 | 45034 | M12x130mm Grade 8.8 Bolt (Not shown) | 2 |
| 7 | 45139 | M12 Nyloc Nut (Not shown) | 2 |
| | 26856k | Baffle Extension Kit (Items 8 to 12) | 1 kit/box |
| 8 | 26855 | Box Baffle Extension (Seeder Centre) | 1 |
| 9 | 24250 | Box Baffle Extension | 2 |
| 10 | 45410S | M8x16 Bolt (Not shown) | 9 |
| 11 | 45137 | M8 Nyloc (Not shown) | 9 |
| 12 | 45151 | M8 Light Flat Washer (Not shown) | 12 |
| | 26856SSk | Baffle Extension Kit Stainless (Items 13 to 17) | 1 kit/box |
| 13 | 26855SS | Box Baffle Extension SS (Seeder Centre) | 1 |
| 14 | 24250SS | Box Baffle Extension SS | 2 |
| 15 | 45410SSS | M8x16 Stainless Steel Bolt (Not shown) | 9 |
| 16 | 45137SS | M8 Stainless Steel Nyloc (Not shown) | 9 |
| 17 | 45151SS | M8 SS Light Flat Washer (Not shown) | 12 |
| 18 | 26858k | Optical Seed Level Indicator | 1 |

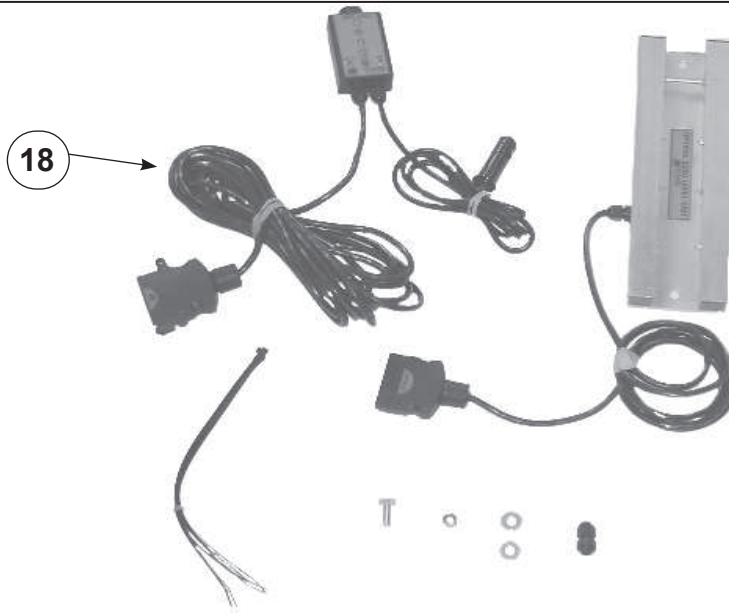

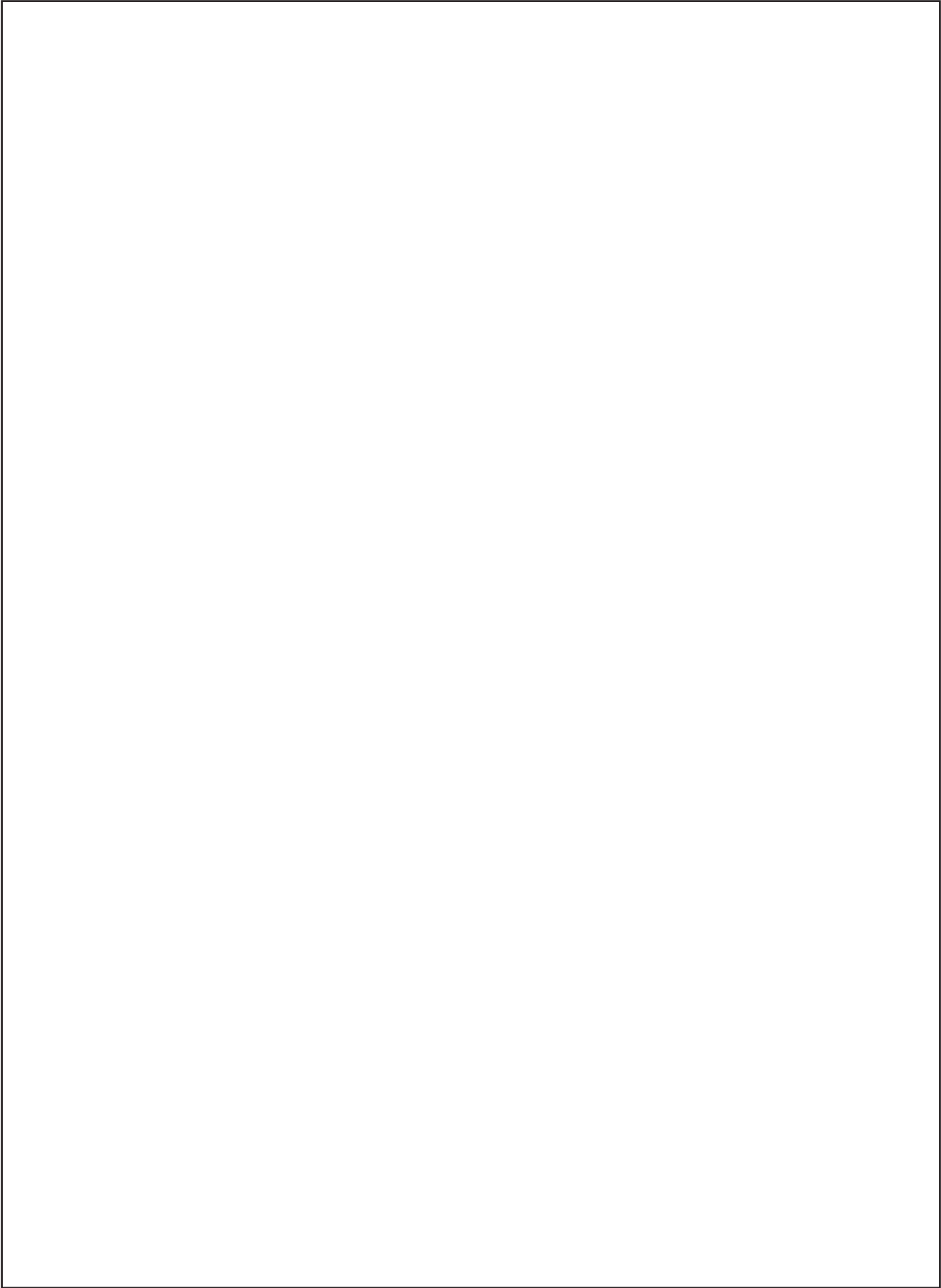



CEproof International Limited
Hilliard House
Lester Way
Wallingford
Oxfordshire OX10 9TA
UNITED KINGDOM

EC DECLARATION OF CONFORMITY

Description of Machine: Agricultural Seed Drill Machine
Make / Model: Duncan Mk3 Renovator & Classic Renovator
Type: 19R & 23R Disc Opener
Serial Numbers: **Mk3 Renovator** CPAC to CPDC 000001-100000
CQAC to CQDC 000001-100000
C319DO 000001-100000
C323DO 000001-100000
Classic Renovator CFAC to CFDC 00001-10000
C/RCDO 00001-10000
Name of Manufacturer: CLOUGH AGRICULTURE LTD
Address: 100 Hilton Highway
Washdyke
Timaru 7910
New Zealand

We hereby declare that the product described above complies with the relevant provisions of the appropriate EC Directives and Harmonised Standards of the European Union listed below and accordingly carries CE-marking.

Machinery Directive 98/37/EC

The following Standards are applicable:

- EN 294 : 1992
- BS EN 982: 1996
- BS 1841-1:1996 / ISO 730-1: 1994
- BS 5499-1: 2002
- EN ISO 12100-2 2003

Date of Declaration: 1st December 2008

Date of Issue: 18th November 2010

Craig McIsaac
Managing Director
Clough Agriculture Ltd

Neil Spencer
CEproof Directives Ltd
Keeper of technical documentation
in the European Union

