

65 YEARS

100%
MADE IN
NZ



Orchard Seeder Operation & Parts Manual



Orchard Seeder Contents

	Page
Introduction	
Acquisition and Warranty	2
The Owner's Manual	2
Description of Machine	
Working Principle	3
Specification	3
SAFETY - General	
Safety Symbols on Machine	4
Operator Safety	5
Be Prepared for Emergencies	5
Appropriate Dress	6
Transport This Machine Safely	6
Handle Agricultural Chemicals Safely	7
Avoid High Pressure Fluids	7
Safe Work Practices	7
Practise Safe Maintenance	8
SAFETY - Machine Specific	
Hazard Points	9
Safety Decals & Safety Guards	11
Transport	12
Operation	12
Sowing Chart	14
Basic Calibration Procedure	
Gearbox Setting Lever	15
Setting Seeder Shutter Slides	15
Bottom Flap Settings	15
Seed Calibration	16
Recalculating the Constant	18
Use of Seed Rate Calculator	18
Calibration Deviations	19
Sowing of Fine Seeds	20
Sowing Small Seeds	21
Sowing Peas	22
Jackal Hectaremeter Settings	23
Calibration Notes	24
Maintenance & Care	
General	25
Lubrication	26
Maintenance Schedule	27
Storage	29
Maintenance Notes	30
Parts Lists	31

Introduction

Acquisition & Warranty

On delivery of your new Duncan Orchard Seeder please check that the machine is not damaged. In cases of shipping damage, please ask your dealer to arrange for the appropriate claim to be lodged immediately. Assemble any parts supplied loose and inspect your machine with the aid of this manual to familiarise yourself with its features. If you have any queries ask your dealer straight away. The machine is covered by our 12 month warranty on faulty parts, subject to normal use.



Record below the serial number of your machine and keep it in a secure place to help trace the machine and assist us when you order parts.

Model:
Serial No:
Owner:
.....
.....
Delivery Date:
Dealer:
.....
.....

This Document contains the Original Operating Instructions for this machine and are verified by the Manufacturer. Signed:..... Product Development Manager
--

The Owner's Manual

Your new Duncan Orchard Seeder will give long and efficient service if given normal care and operated properly.

This owner's manual is provided so that you can become thoroughly familiar with the design of the machine and to furnish information on correct operation, adjustment and maintenance. **Only persons well acquainted with these guidelines should be allowed to use the equipment.**

A separate illustrated parts section has been provided so that if any parts are required your dealer will be able to supply them by reference to part numbers.

The manual is considered as part of your machine and must remain with the machine when it is sold.

Right and left hand references in this manual are determined by standing behind the machine and facing in the direction of travel.

Disclaimer Every effort has been made to ensure that the information in this manual was accurate and up to date at the time of going to press. Clough Agriculture reserves the right to make subsequent changes to the machine, where necessary, without notification. The Company will not be responsible for any damage or consequential loss arising out of misinterpretation or failure to follow recommended procedures. Nor will it be liable for any damage caused by or arising out of modification or misuse of its product. The owner has a responsibility to protect himself and others by observing all safety information and by ensuring all operators are well acquainted with the safety information, trained in the correct use of the machine and applying safe work practices.
--

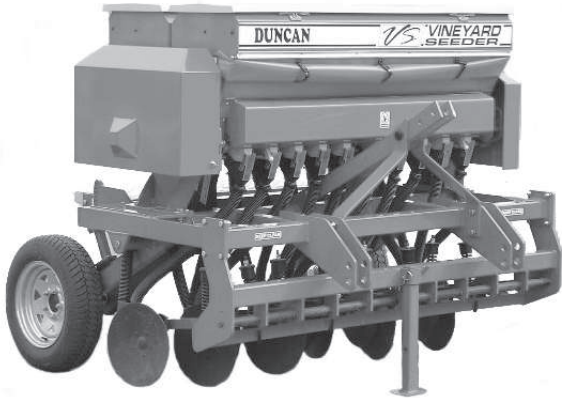

Description of Machine

The Duncan Ag Orchard Seeder is a double disc drill with dual boxes for seed and fertilizer. The drill is carried and operated from the three point linkage of the tractor. The sowing depth control is achieved from two trailing wheels with individual wheel retraction stops. The right hand depth control wheel is also the drive wheel for the seeder unit. A wide variety of seeds can be sown from the seed box, from small seeds like turnip and rape to large seeds like peas and maize.

Working Principle

The gearbox, pegged seed rollers and seeder flaps are set to give the desired seed rate. The disc(s) create the seed bed. Seed flows down the flexible tubes between the seeder and the coulters casting units, and drops into the prepared seed bed.

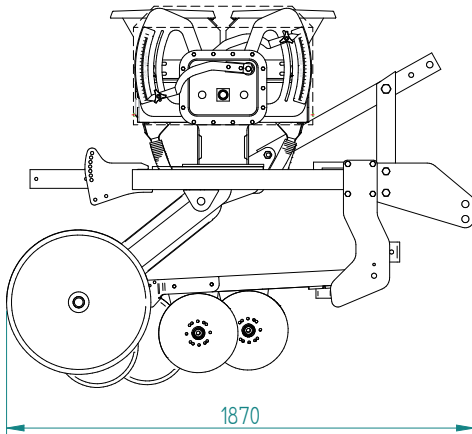

Dimensions & Capacities	
Overall Width	1905mm
Length Overall	1870mm
Height (Depth Wheels Up)	1480mm
Weight (Unladen)	750kg
Depth Wheel Tyre Size	155R13
Tyre Pressure (Max)	2.4 bar (35 psi)
Row Spacing	150mm
Sowing Width	1650mm
Box Capacity (per box)	130 litres

Estimated weight excludes press wheels

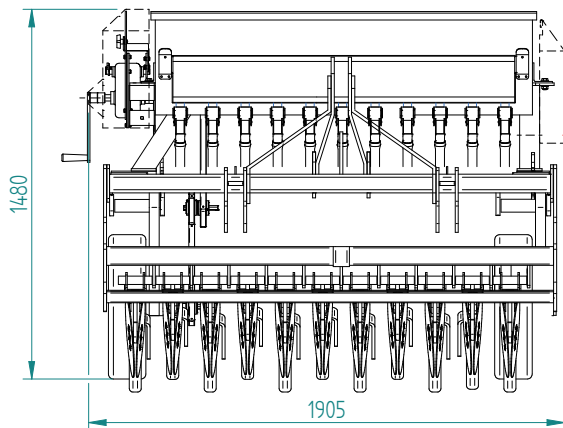



ATTENTION

On the machine important safety information is indicated by these symbols. These highlight general safety aspects in regard to the machine rather than specific hazards.



Do not ride or allow passengers on the machine.

Under no circumstances are passengers to be permitted on the machine while it is in operation or being transported. Any footboards and/or footsteps are provided solely for the purpose of preparing the machine for use.



Keep clothing and body extremities well clear of pinch points while the machine is operating (seeding or calibrating). Keep well clear of moving parts at all times.

These signs typically occur wherever trapping points exist. These include drive chains, sprockets, shafts, wheels, discs, pivot points, etc. Guards are provided with the machine for safety reasons (where practical without compromising machine performance). Ensure these are always fitted during operation.



Always exercise extreme caution in the vicinity of sharp edges and points.

Where possible guards are provided with the machine for safety reasons (where practical without compromising machine performance). Ensure these are always fitted during operation.



Footboards, footsteps, drawbars and other machine surfaces may be slippery when wet.

Apply extra caution in wet conditions and in the early morning when surfaces are wet.

KEEP CLEAR

Keep Clear. (It is dangerous to be in this area when the machine is operating.)

SAFETY - General

N.B. Throughout this manual important safety information is indicated by these symbols in the margin:



A prohibition should be observed under all circumstances



A warning indicates a hazard that could cause death or injury if the warning is ignored.



A caution indicates a hazard that may cause damage to property if the caution is ignored.

This section of the manual offers general guidelines for the safe operation of machinery. It does not replace local safety regulations. These guidelines were current at the time of publication, but may be superseded by later regulations.

Duncan Ag has made every effort to highlight all risks to personnel or property. Owners and operators have a responsibility to exercise care and safe work practices at all times in the vicinity of the machine.

Owners are advised to keep up to date on safety issues and to communicate these to all users of the machine.

Contact the Occupational Safety and Health Service (OSH) for further information about general safety aspects. If you have safety concerns specifically related to this machine, contact your dealer immediately.

Operator Safety

Read this manual carefully before operating new equipment. Learn how to use this machine safely. Be thoroughly familiar with the controls and the proper use of the equipment before using it.



Take careful note of all safety instructions both in this manual and on the machine itself. Failure to comply with instructions could result in personal injury and/or damage to the machine.

Replace missing or damaged safety signs on the machine and ensure that these remain clearly visible.

It is the owner's responsibility to ensure that anyone who operates, adjusts, lubricates, maintains, cleans or uses the machine in any way has had suitable instruction and is familiar with the information in this manual (particularly with regard to safety aspects).

Operators and other users of the machine should be aware of potential hazards and operating limitations.



Be Prepared for Emergencies

Keep a first aid kit and fire extinguisher handy.

Keep emergency numbers for doctors, ambulance, hospital and fire department near your telephone.



SAFETY - General (Continued)



Appropriate Dress

Wear close fitting clothing and avoid rings or other forms of jewellery which could become caught in the machinery.

People with long hair must have it securely fixed and confined close to the head.

Refer to local safety standards for protective clothing and recommended safety equipment.



Transport This Machine Safely

Ensure that all linkage pins and security clips are fitted correctly. With trailing machines tow with the drawbar only, as this is the only safe towing point on the machine.

Always check that bystanders (especially children) are well clear (front and rear) before starting and moving the tractor and the machine.

Plan safe routes of travel, and be aware of power lines and other roadside hazards. Take particular care when towing implements on hillsides.

Do not ride or allow passengers on the machine.

This machine is not designed to carry passengers, and no riders are permitted.



Road transport

On public roads,

- A speed of 40km/h must not be exceeded.
- Do not operate during the hours of darkness unless standard lights are fitted and clearly visible. (This also applies when visibility is limited, e.g., in foggy conditions.)

See the guidelines in the *Vehicle Dimensions and Mass Rule*, issued by the Land & Transport Safety Authority.

Avoid tip-overs

Avoid holes, ditches and obstructions which may cause the machine to tip over, especially on hillsides. Never drive near the edge of a gully or steep embankment - it might cave in. Slow down for hillsides, rough ground and sharp turns.



SAFETY - General (Continued)

Handle Agricultural Chemicals Safely

All farm chemicals should be stored, used, handled and disposed of safely and in accordance with the supplier's/manufacturer's recommendations.



Read the product label before using, noting any warnings or special cautions, including any protective clothing or equipment that may be required, ie. respirator.

Do not eat or smoke while handling sprays, fertilisers, coated seeds, etc. Afterwards, always wash your hands and face before you eat, drink, smoke, or use the toilet.



Store sprays, fertilisers, coated seeds, etc. out of reach of children and pets, and away from food and animal feeds.

Any symptoms of illness during or after using chemicals should be treated according to the supplier's/manufacturer's recommendations. If severe, **call a physician or get the patient to hospital immediately.** Keep the container and/or label for reference.

Avoid High Pressure Fluids

Avoid any contact with fluids leaking under pressure, because the fluids can penetrate the skin surface.



Any fluid which penetrates the skin, will need to be **removed immediately by a medical expert.** Seek specialist advice on this type of injury.

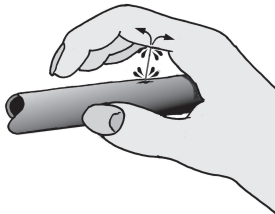

Relieve the pressure before disconnecting any hydraulic or other lines. Make all repairs and tighten all fittings before re-connection to pressurised fluid.

Keep your hands and body away from any pinholes or high pressure jets. Search for leaks with a piece of cardboard instead of using your hand directly.

Safe Work Practices

All farm machinery is potentially dangerous and should be treated with caution and respect.



Before starting the machine, ensure that all controls are placed in neutral and that bystanders are well clear. Check that the guards have been securely fitted and that any adjustments have been made correctly.

Where possible, disconnect or isolate the drive mechanism to the implement. Lower the machine onto the ground when not in use.

SAFETY - General (Continued)



Practise Safe Maintenance

Keep the machine in safe working condition. Routine maintenance and regular servicing will help reduce risks and prolong the life of the machine.

General Maintenance

Accidents occur most frequently during servicing and repair. The following general rules must be followed when maintaining or working with machinery:

- All operating and maintenance manuals must be read before and referred to while using or servicing any piece of equipment.
- Turn off all machinery power sources and isolate the machine before making adjustments, doing lubrication, repairs or any other maintenance on the machine.
- Ensure that the machine hydraulics are disconnected from the power source.
- Wear gloves when handling components with cutting edges, such as any ground cutting components.
- Beware of hazards created by springs under tension or compression when dismantling or maintaining the machine.
- It is recommended that you clean the machine with a water blaster or similar apparatus before commencing maintenance.

Make Sure the Machine is Well Supported

When machinery is fitted with hydraulics, do not rely on the hydraulics to support the machine. During maintenance or while making adjustments under the machine, always lock the hydraulics and support the machine securely. Place blocks or other stable supports under elevated parts before working on these.

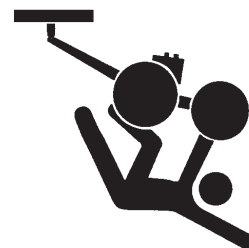

Electrical Maintenance

Disconnect the electrical supply from the tractor before doing any electrical maintenance.



Welding

With electronic equipment in modern tractors it is advisable to disconnect the machine from the tractor, or at least disconnect the alternator and battery before attempting any welding.



Use Only Genuine Spare Parts

Unauthorised modifications or non-genuine spare parts may be hazardous and impair the safe operation and working life of the machine.

Excess lubricants must be disposed of safely so as not to become a hazard.

SAFETY - Machine Specific

This section of the manual gives specific guidelines for the safe operation of the Orchard Seeder.

These guidelines were current at the time of publication, but may be superseded by later circumstances. They do not necessarily cover every possible hazard and must be read in conjunction with the **SAFETY - General** section (Page 4 - 8).

Hazard Points on the Orchard Seeder

The lists below are not all-inclusive and serve only to highlight the more obvious areas of risk.



The decals attached to the machine are a general reminder that there are hazardous areas on the machine, rather than specifically highlighting all possible hazards.

For decal locations on machine, refer Page 11.



No Ride

Passengers are not permitted anywhere on the machine.



Pinch Points/Moving Parts

Hazardous areas include:

- Drive chains.
- Sprockets between the gearbox and the box shafts (RH side).
- Agitator drive units (LH side).
- Agitator shaft inside the boxes.
- Seeder units, box shaft and shaft connectors.
- Discs.



**Slippery
When
Wet**

Slippery When Wet

Hazardous areas include:

- Footboard.
- All smooth surfaces on the frame structure.

KEEP CLEAR

Keep Clear

Hazardous areas include:

- Between the tractor and Orchard Seeder.
- Immediately adjacent to the Orchard Seeder side.

SAFETY - Machine Specific (Continued)



Hazard Points on the Orchard Seeder (Continued)

Guards

Gearbox deflection and flap handle guards are provided to avoid grape vines getting caught up in componentry. They also assist in preventing hands getting caught up in sprockets, drive chains and chain tensioners. These guards must be fitted while the machine is in use.

Warning: Access to pinch points is still possible from underneath or behind the guards.

For guard locations on machine, refer Page 11.

Box Lifting Profiles

The box set lifting profiles mounted to the dual box assembly ends are provided for easy removal of the boxes from the pedestals. Do not use to lift the machine.

Calibrating

Be particularly careful when calibrating the seeding rate. At this time, the calibration trays have been removed and are no longer covering the rotating seeder units. See **Pinch Points/ Moving Parts** (Page 9) for hazardous areas.



Transport

The two wheels located at the rear of the machine (one on each side) are for the purpose of disc depth control and gearbox input drive. These must not be used to support the machine weight during transport (while linked to the tractor).

Ensure that all linkage pins and security clips are fitted correctly. Refer Page 12 for important information.

Maintenance

Refer Page 25 - 30 for reference to the **Maintenance & Care** section of the manual.

Lubrication

Refer Page 26 for reference to the **Lubrication** section of the manual.

SAFETY - Machine Specific (Continued)

Safety Decals & Safety Guards

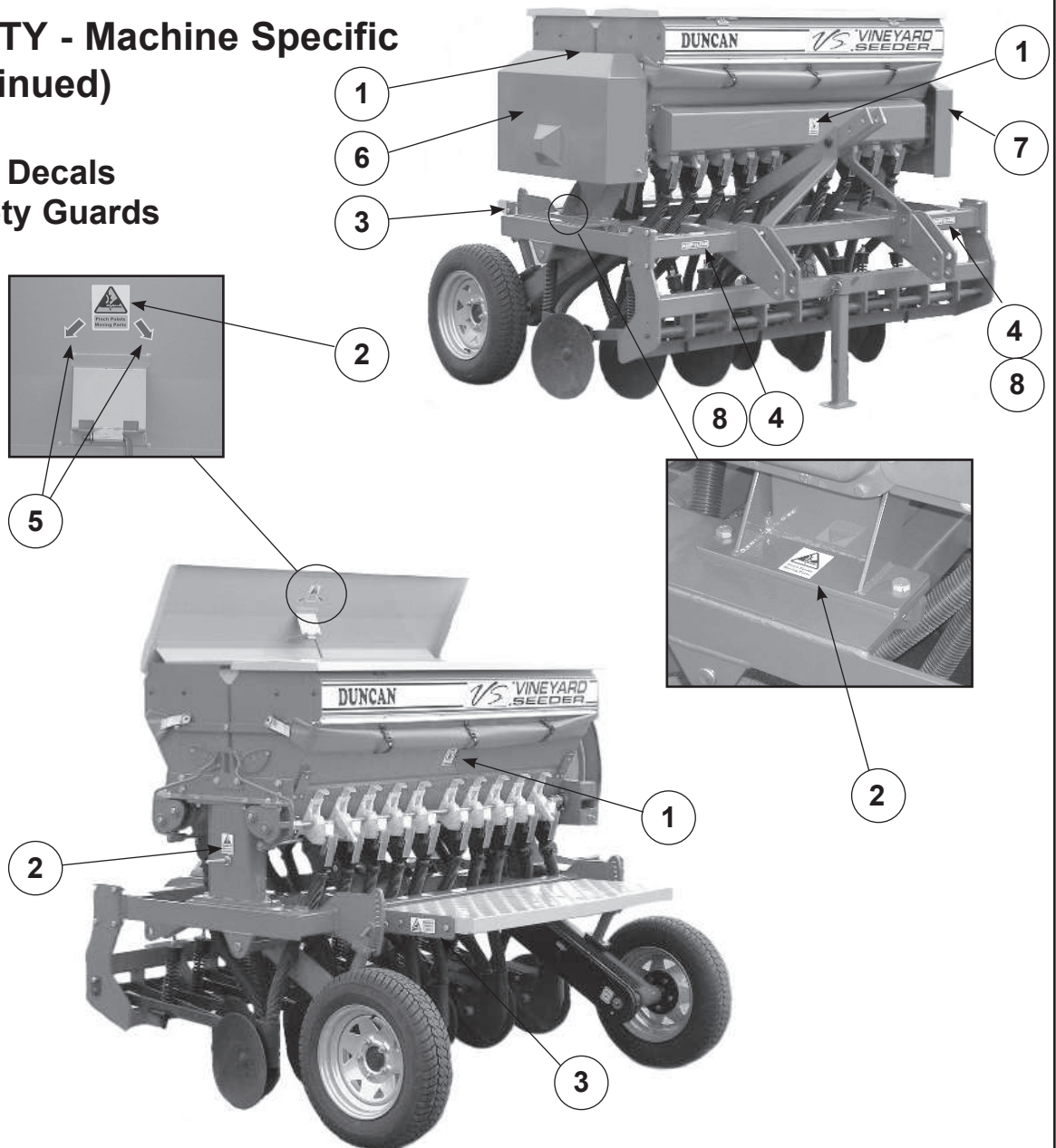

Item	Decal/Guard	Pt. No.	Qty
1	'No Ride'	43900	3
2	'Pinch Point/Moving Parts'	43901	5
3	'Slippery When Wet'	43902	2
4	'Keep Clear'	43904	2
5	Arrows (Inside Box Lid)	43905	4
6	Gearbox Deflection Guard	27394	1
7	Flap Handle Guard	27445	1
8	'40km/hr'	43911	2



Transport

- 1 Raise the three point linkage as high as possible to maximise ground clearance. Ensure ground clearance is sufficient. Do not transport with the wheels in contact with the ground.
- 2 Ensure that all linkage pins and security clips are fitted and are secure.
- 3 Ensure that the jack stand has sufficient ground clearance. Raise into the upper position if required.
- 4 Ensure lighting and oversize warning requirements meet recommendations published by the local Land Transport Authority or equivalent.
- 5 **Maximum towing speed 40 km/hr.**
For countries other than New Zealand greater speed restrictions may apply, please refer to your local transport authority.

Ensure towing vehicle requirements are adequate for the towed vehicle e.g. mass, brakes. Refer to recommendations published by the local Land Transport Authority or equivalent.

Lower towing speeds are recommended on farm roads/tracks and where one wheel is on or over a road verge.

Operation

General Operation Guidelines

- 1 Use a sufficiently powerful tractor which is heavy enough to operate the drill safely.
- 2 Operate the drill at a speed of 6-12 km/hr (4-8 mph). In stony and uneven ground conditions a lower speed is more appropriate.
- 3 Check that the drill is level during calibration and while seeding.
- 4 Check tyre pressure before seeding. Refer page 3.
- 5 Double check seed rates before seeding.
- 6 Raise the drill out of the ground when making any turns.
- 7 Raise the drill out of the ground before backing up.
- 8 Ensure the jack stand is in the raised position.
- 9 After prolonged storage, check to see that all drive mechanisms and hydraulic equipment are functioning correctly. Check that the seed tubes are not perished or blocked.

Sowing Speed

Typical travel speeds when sowing range from 6-12 km/hr in good conditions. In stoney and uneven ground conditions a lower speed is recommended to minimise rapid part deterioration. Sowing too fast can result in:

- 1 Poor contour following and uneven sowing depth.
- 2 Impact damage to:
 - a Ground engaging components.
 - b Bearings, housings & axles.
 - c Fasteners & structural components.
- 3 More extreme conditions will result in greater vibration and uneven seed flow at low seeding rates.

Sowing Depth Control

The sowing depth is dependent on:

- 1 The wheel height in relation to the chassis.
- 2 Dragbar spring pre-compression.
- 3 Tyre pressure.
- 4 Ground condition i.e. hard, soft, how even.

The wheel height in relation to the chassis is controlled using the wheel retraction stop. To adjust the wheel height;

- a Lift the drill using the three point linkage sufficiently to unload weight on the wheel.
- b Loosen the M12 nyloc nuts on the clamp plate assembly (1).
- c Remove the R clip and pin (2).
- d Adjust the wheel retraction stop (3).
- e Refit the pin, R clip and retighten the nyloc nuts. Refer Fig 1.

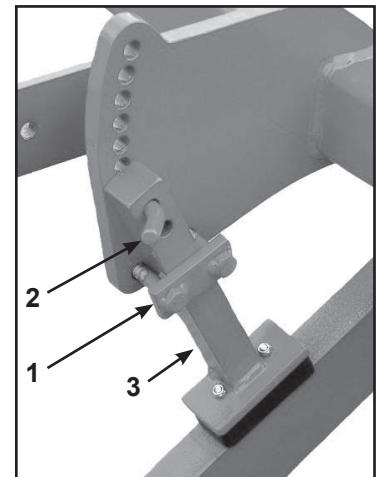

Fig 1

A more constant sowing depth is achieved with minimal dragbar deflection. With harder ground conditions more spring pre-compression may be required. Adjust the M10 plain nuts (1) as desired. Refer Fig 2. Note, less spring pre-compression will allow the disc to ride over rigid obstacles, eg stones.

In bumpy or undulating ground conditions the drive wheel will drop away from the wheel retraction stop to maintain seeder drive.

Avoid sowing through dips with a rigid top link. Excessive loads will be transferred through the linkage stays to the wheel which may cause componentry damage. If possible use a floating top link. When sowing over ridges the drive wheel may lose contact with the ground temporarily.

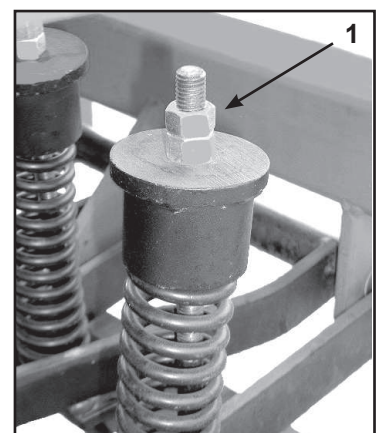

Fig 2

Disc penetration ability will improve as discs sharpen with initial use.

Orchard Seeder Sowing Chart

Row Spacing 150

150														
PRODUCT	Shutter Slide*	Bottom Flap*	Metering Wheel*	Seed Rate (kg/ha) Gearbox Setting Position										Agitator Shaft
				15	20	30	40	50	60	70	80	90	100	
	Position		Type											Connected
Wheat	3/4	3	N					98	125	147	174	201	226	Connected
Oats	Full	3	N					96	119	142	166	190	212	Connected
Barley	Full	3	N					114	140	170	198	229	257	Connected
Ryecorn	3/4	3	N					115	143	173	200	233	262	Connected
White Peas	3/4	3	N			108	156	206	238	295	347	384	442	Disconnected
Green Peas	3/4	3	N			75	113	151	186	223	263	305	344	Connected
Peren. Grass	Full	3	N	6	13	26	40	52	65	79				Connected
Annual Grass	Full	3	N	8	16	31	44	59	74					Connected
Pasture Mix*	Full	3	N		13	26	40	53	65	79				Connected
Lucerne	3/4	1	F			9	13	17	22	25				Disconnected
Turnip	3/4	1	F	2	5	8	12	15						Disconnected
Kale	3/4	1	F		4	8	12	15						Disconnected
Swedes	3/4	1	F	2	4									Disconnected
Rape	3/4	1	F		4	7	11	14						Disconnected
White Clover	3/4	1	F	2	4	8	11	14						Disconnected
Red Clover	3/4	1	F		5	9	13	17						Disconnected
Super Phosphate	Full	3	N			88	136	179	227	277	332	384	442	Connected
DAP Granules	Full	3	N					168	206	248	292	335	370	Connected

Shutter Slide*: For Grain, changing the Shutter Slide from 3/4 to Full gives 10% to 15% more flow.

Pasture Mix*: Test Mixture = 72% Perennial Grass, 8% White Clover, 8% Cocksfoot, 8% Concord, 4% Red Clover

Bottom Flap*: The values shown were the optimum test settings, decreasing the gap may cause seed damage, too large a gap will give intermittent flow rates. (Flaps are spring loaded to cope with small variations in seed/granule size).

Basic Calibration Procedure

Gearbox Setting Lever

To set the seed rate at the gearbox, slacken the star knob (1) by turning counter-clockwise and push from below into the position indicated in the Sowing Chart. Retighten the star knob firmly (Fig 3).

Important

The settings shown in the Sowing Charts (kg/ha) can only serve as reference values. Deviations may occur caused by differences in the size, shape, density of the grain and by the dressing agent. **Therefore prior to any sowing, always carry out calibration trials to accurately determine the actual seed rate.**

Using the stepless variable speed gearbox, the speed of the metering shaft and thus the seed rate is set steplessly. The higher the figure indicated on the scale by the setting lever the greater the seed rate (Fig 3).

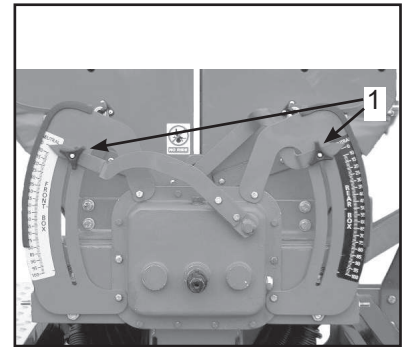

Fig 3

Setting Seeder Shutter Slides

The varying flow properties of seeds require different shutter slide positions which may be found in the Sowing Chart for the individual type of seed. This corresponds to one of the three settings in Fig 4.

Fig15/A	Fig15/B	Fig15/C
Closed	3/4 Open	Fully Open

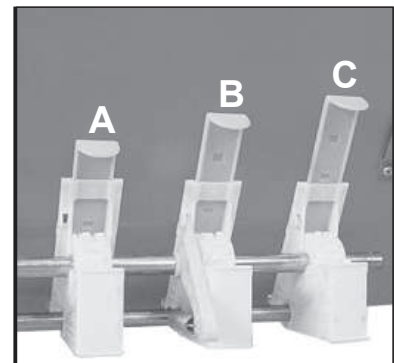

Fig 4

Bottom Flap Settings

The various seed sizes require matching bottom flap clearances below the metering wheel. The adjusting plate allows for 10 different settings. The required position for the seed type may be found in the Sowing Chart. The control levers are located on the LH end of the seedbox, (opposite end to the gearbox).

Number "1" corresponds to the minimum (closed) position and "10" the maximum gap (Fig 5).

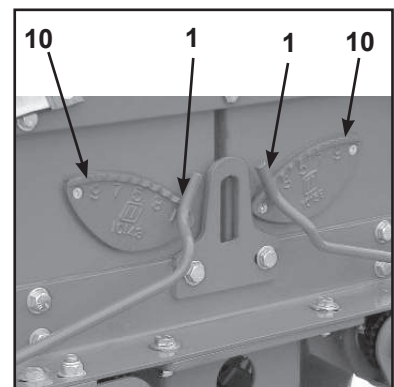

Fig 5

Basic Calibration Procedure (Continued)

Seed Calibration

The calibration test should be done to confirm the required seed rate and is done with the drill stationary and level.

Seed Calibration Procedures

- 1 Remove the calibration tray from the storage brackets on the seedbox. Place the calibration tray (1) adjacent to the seeder units (Fig 6).
 - 2 Position all the clear plastic seed diverters (2) to redirect the seed into the calibration tray (Fig 6).
 - 3 Make sure all the shutters are open and set to the position indicated in the seed charts for the particular seed (Table 2, Page 14).
 - 4 Check the **Sowing Chart** 'Hints' (Page 14) to see whether to connect or disconnect the agitator shaft by removing the lynch pins (1) during seeding (Fig 7).
 - 5 For the test, half fill the box with seed. If this is not possible make sure the seed is evenly distributed within the box.
 - 6 For setting method refer to **Basic Calibration Procedure** (Page 15).
- Note** For seeds which are not covered in the **Sowing Chart** (Page 14), use the figures for a seed of comparable size and shape.
- 7 Place the crank handle over the hexagonal drive dog on the gear box and turn clockwise until the seed flows consistently from the seeders (Fig 8). To ensure complete filling of the seed unit continue turning the crank until the calibration tray is approximately half full then empty into the seedbox. The drill is now ready for calibration.

(Continued on Page 17)

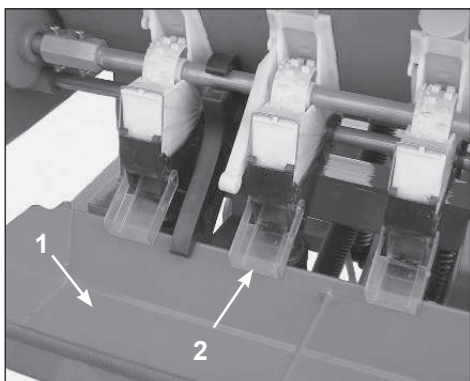

Fig 6

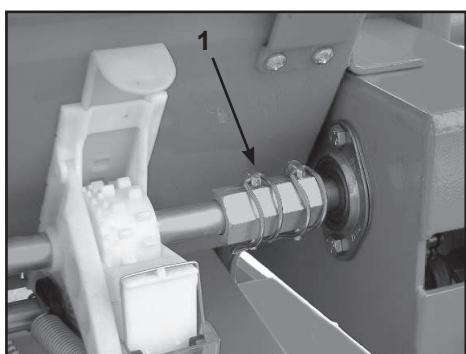

Fig 7

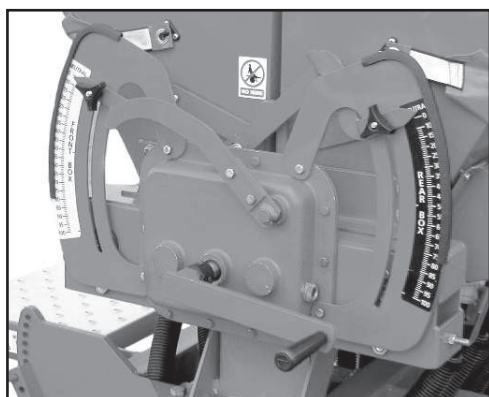

Fig 8

Basic Calibration Procedure (Continued)

Seed Calibration Procedures (Continued)

- 8 Turn the crank handle clockwise the required number of revolutions as detailed in Table 3.

Note The Calibration is usually done for 1/80th hectare. For very small seed rates or when using inaccurate scales (i.e. unable to measure to the nearest gram) the calculation based on 1/20th hectare should be used.

Hand Crank Turns for Seed Rate Calibration

The tables represented below are for arable conditions (**worked ground**) and are calculated to indicate an average situation. If there is any doubt as to the accuracy of these figures for the conditions, it is advisable to run at least 1 of the 2 checks on the calibration figures listed. Refer Page 18 (**Recalculating the Constant**) and/or Page 19, (**Wheel Slip Deviations**). Check and record which tyres are fitted to your drill, to ensure use of the correct Hand Crank Turn and Constant figures.

Sowing Width (m)	Turns for 1/80 Hectare	Turns for 1/20 Hectare
1.65	34	135

- 9 Weigh the seed collected during the test in kilograms.

Scales must be accurate to 2 grams, as any error will be multiplied by either 20 or 80, giving inaccurate calibration results.

- 10 Calculate the seed rate by multiplying the kgs previously collected x 80 (1/80th ha method, refer Table 4) or x 20 (1/20th ha method, refer Table 5) depending on the requirement. If the resultant calculation does not produce the desired seed rate use the enclosed seed rate calculator disc to determine the correct gearbox setting.

Refer **Use of Seed Rate Calculator** Page 18

Suggestion: To be on the safe side and until confidence has been gained with the method of calibration it is advisable to conduct a second test at the newly determined gearbox setting.

<p>For $\frac{1}{80}$ Hectare (125m²) Calibration Seed Rate = Actual Seed Collected (kg) x 80</p>

Table 4

<p>For $\frac{1}{20}$ Hectare (500m²) Calibration Seed Rate = Actual Seed Collected (kg) x 20</p>

Table 5

- 11 Where a coated seed is used it is advisable to check the calibration after 1 hectare as dressings can tend to create a coating on the seed metering wheels thus changing the the flowing properties of the seed which in turn alters the seed rate.

Basic Calibration Procedure (Continued)

Recalculating the Constant

It is especially important in arable situations to check the rolling circumference of the tyre when in the cultivated area to be sown, and if necessary, to recalculate the constant and hence the number of crank turns.

If there is a significant difference between the figure used for calculations in this manual, the constant should be recalculated and hence the crank turns for those particular conditions.

Note: If a significant difference is found in the rolling circumference the 'Manual Ratio' setting should also be adjusted on the Jackal Speed and Area Meter.

1 To recalculate the constant due to altered conditions or specific requirements use the formulae detailed in Table 4 or 5 (Page 17).

2 **To obtain the rolling circumference of the tyre:**

Half fill the seed/fertiliser boxes or simulate this loading.

Mark the tyre of the drill at 90° to the ground and the point of contact with a mark on the ground. Move the drill forward 5 revolutions until the mark on the tyre is again at 90° to the ground. Measure the distance along the ground and divide by 5 to give the rolling circumference of the tyre.

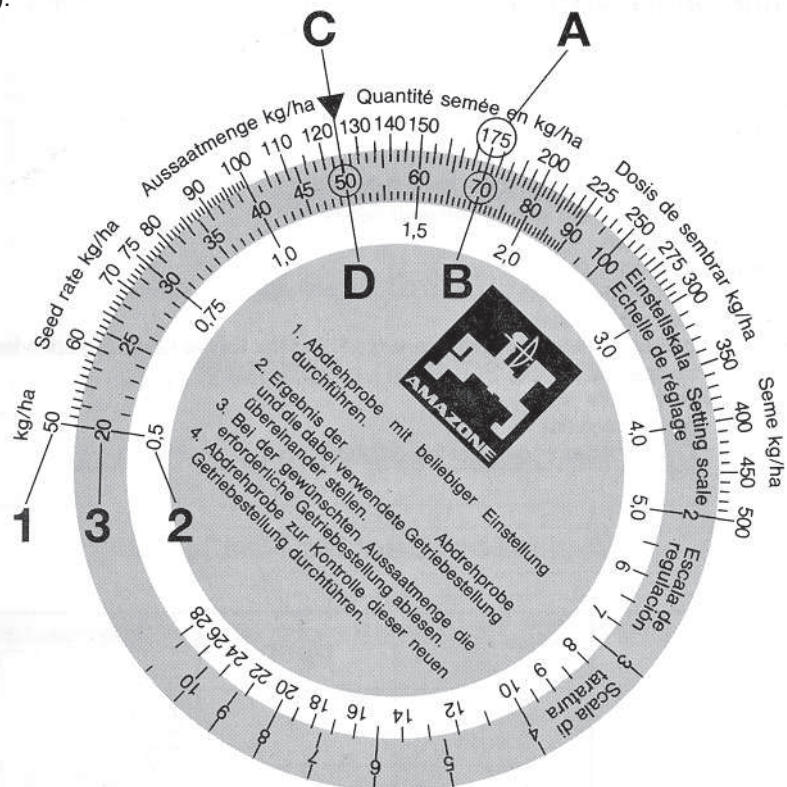

Fig 9

Use of Seed Rate Calculator

Determining the gear box scale setting using the calculator.

Usually the first calibration test yields a different seed rate. However with the value determined from the first test it is possible to determine the correct gearbox setting with the aid of the enclosed disc calculator (Fig 9). The disc calculator consists of 3 scales. An outer white scale (1)

Setting Example (Desired Seed Rate 125kg/ha)

- 1 From the calibration procedure at a gearbox lever setting of "70", a seed rate of 175 kg/ha is obtained.
- 2 Turn the inner disc until the measured seed rate of 175kg/ha (A) is in line with the related actual gearbox setting of "70"(B) (Fig 9).
- 3 Read off from the disc rule the necessary gearbox setting for the required seed rate of 125kg/ha (C). In this example the correct setting is "50" (D) (Fig 9).
- 4 To be on the safe side the new gearbox setting can be checked by another calibration test.

Basic Calibration Procedure (Continued)

Calibration Deviations

Deviations Between the Calibration Test and the Actual Seed Rate

The most frequent cause for changes between the calibration test and the seed rate lies in the flowing properties of seed during sowing. These changes in properties generally result from reactions of the dressing agents to temperature, humidity or abrasion. These changes will become even more obvious when the bottom flaps are incorrectly set. If the setting of these flaps leaves too large a gap an uncontrollable additional flow of seed can occur during seeding; especially when assisted by the drill bouncing, a condition not simulated while conducting the calibration tests. For this reason the basic setting of the bottom flaps should be checked at regular intervals.

Residues from the seed dressing on the bottom flaps and metering wheels can also influence the flowing properties of the seed and thus the seed rate. In such cases a balance will occur only after a period of time and it is recommended to repeat the calibration test to confirm the seed rate after 2-3 seedbox fillings, nominally when the seed box is half empty.

Only then will a balance occur and the seed rate will stabilise.

Wheel Slip Deviations

It is always possible with rubber tyred drills in extreme ground conditions to get wheel slip. Not normally a problem with cleated type tyres in good condition, but more so in the arable situation with the less aggressive tread patterns. The result: large differences between the calibration test and the actual sowing rate, obviously less seed deposited than required. The number of crank turns indicated in Table 3 is correct in most circumstances other than those mentioned above.

To check number of crank turns for calibration

Should you require to check this in a practical way proceed as follows:

For an area of 125m² (1/80 Hectare), a travel distance of 75.7m, place the crank handle over the hexagonal drive dog on the gearbox. Move the machine forward over the measured distance, counting the number of turns of the crank handle as you go. Using this number of crank turns repeat the calibration.

Basic Calibration Procedure (Continued)

Sowing Fine Seeds

For sowing fine seeds the Orchard Seeder is equipped as standard with a combined normal and fine seed "Elite" metering wheel (1). During grain sowing and other larger varieties of seed both the normal and fine seed metering wheels are coupled and both rotate. In order to convert the seed drill to sow fine seed insert the crank handle and rotate clockwise until the holes (2) of the fine seed wheel are visible (Fig 10).

Using the tool supplied (Fig 11/1) disengage the the pin inside the hole so that the normal metering wheel rotates freely on the metering shaft.

At this time it would be advisable to close any shutter slides not required for the fine seed sowing.

When seed is to be sown again using the normal metering wheel press the pin, from the normal metering wheel side (opposite direction to before), using the tool, back into the hole of the fine seed wheel thus reconnecting the drive between the two.

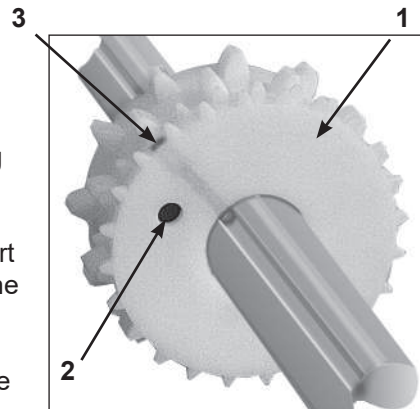

Fig 10

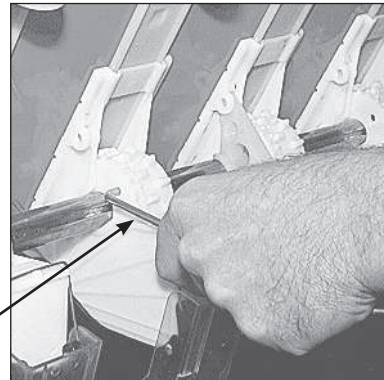
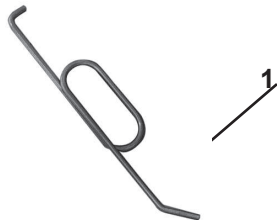

Fig 11



Basic Calibration Procedure (Continued)

Sowing Small Seeds

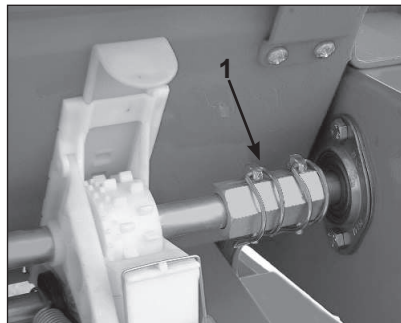

Fig 12

Calibration with Disconnected Agitator Shaft

The fine seed metering wheel used in Duncan Drills is especially well suited for sowing small seeds such as rape. Due to the intensive action caused by the agitator the seeds can adhere to each other, or be damaged, causing irregular sowing/germination. **Therefore it is recommended that when sowing small seeds, especially oil seeds and thin shelled seeds, the drive to the agitator is disconnected.** To do this remove the lynch pin (1) (Fig 12).

Deviations between the calibrated and actual seed rate can occur when residual dressing agent sticks to the bottom flaps and thus slows the flow of seed. Before beginning the actual calibration test fill the calibration trays by turning the crank handle at a high speed around the 90 setting on the gearbox scale. This will cause an immediate buildup of the dressing agent on the flaps. Return the contents of the calibration trays to the seed box and proceed with the actual calibration. Due to the residue buildup on the flaps your calibration will now reflect accurately the required seed rate. It is advisable with small seeds to use the 1/20 hectare method for your calibration, thus cutting down on weighing errors.

Note: Remember to reconnect the agitator shaft as required for other seeds, otherwise the consistency of seed rate will be affected.



Caution: When resetting the metering wheels on the seeder shaft

CAUTION Care should be taken when tightening the grub screws on the fine seed wheel (Page 20, Fig 10/3). Adjust the grub screw until the movement of the metering wheel just stops, then tighten no more than 1/8 of a turn.

Do not overtighten as this can result in breakages while operating and may render the warranty on these units void.

Basic Calibration Procedure (Continued)

Sowing Peas

Peas having the size and shape as illustrated in Fig 13 (e.g. White Field Peas), can be sown without problems with all Duncan Drills with this type of metering wheel.

The flap should be set to a gap of at least "3" on the flap setting lever (Page 15, Fig 3).

With these peas it should not be necessary to run the agitator shaft.

Peas having the size and shape as illustrated in Fig 14 (e.g. Green or Garden Peas), tend to bridge inside the seedbox and do not flow freely. This multi-faceted pea requires agitation for sowing.

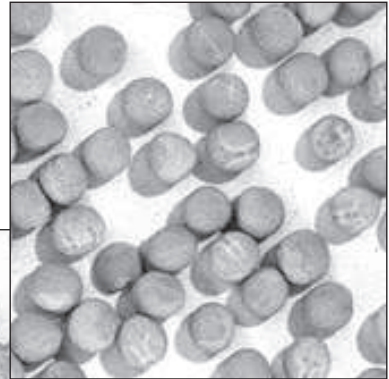

Fig 13

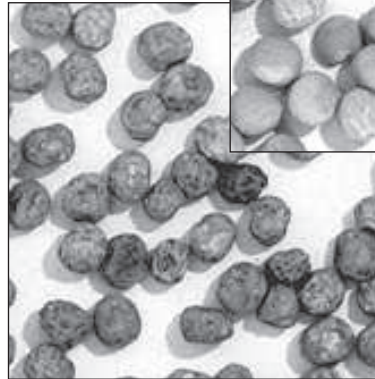

Fig 14

Farmscan Jackal Settings Setup

Refer to the manual supplied with your Farmscan Jackal kit for information and operation.

Farmscan Jackal Factory Setup for Orchard Seeder

Refer to the Farmscan Jackal manual.

Input 2 - Three wire proximity sensor for 'Area/Speed Wheel' measurement taken from shaft on drive pedestal.
The white 'signal' lead is connected to input A2.

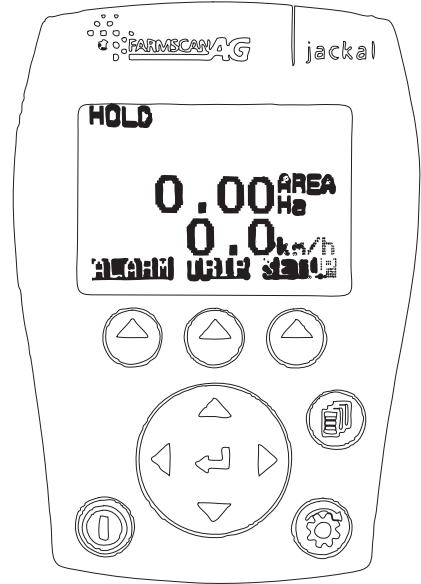

Input 2 Edit	
m/pulse	
Auto Set:	
Target:0.000m	
Meas.pulses:	0
Manual Ratio:	2.224000
NEXT	EDIT

Other Settings	
Implement Width:	x.xxx m
Extern.Run/Hold:	Disabled
Alarm Beep:2	
NEXT	EDIT

Rolling Circumference of Tyre = 1.8m (refer Page 18)

The 'drive ratio' is always 0.8095

$$\begin{aligned} \text{Manual Ratio} &= \frac{\text{Circumference of Tyre}}{\text{Drive Ratio}} \\ &= \frac{1.8 \text{ m}}{0.8095} \\ &= 2.224\text{m} \end{aligned}$$

Machine Size	Row Spacing (mm)	Sowing Width (m)
11 Run	150	1.65

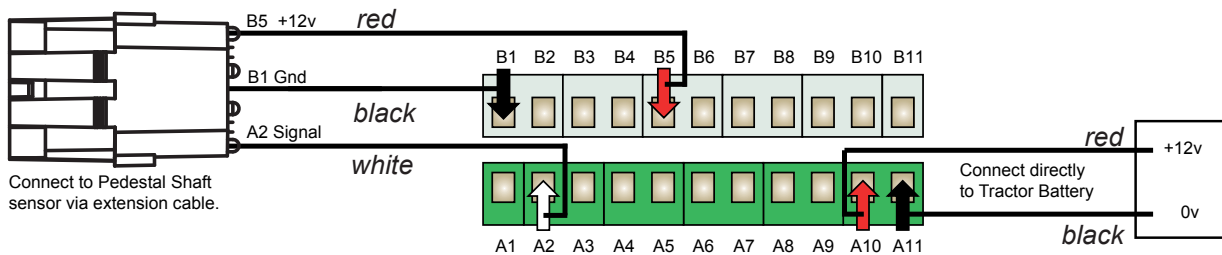

Refer to the Farmscan manual if you want to make additional sensor connections.

It is advisable, as with all things electronic, to have a backup of your totals. We suggest you record these on a daily basis in a notebook or diary.

Maintenance & Care - General

General Safety and Accident Prevention Advice

- 1 Make sure that if the tractor remains attached to the drill that the ignition key is removed.
- 2 During maintenance the drill should be supported in such a manner that if hydraulic failure was to occur the machine would still be adequately supported.
- 3 Wear gloves when handling components with cutting edges such as worn discs etc...
- 4 Disconnect the electrical supply from the tractor before doing any electrical maintenance.
- 5 Refer to safety sections for more safety information.

General Cautionary Maintenance Advice

- 1 **Electric Welding** - With the electronic equipment in modern tractors it is advisable to completely disconnect the implement from the tractor, or at the very least disconnect the alternator before attempting any welding.
- 2 **Water Blasting** - Water blasting, steam cleaning or other pressurised cleaning processes can force dirt etc. into undesirable places that may cause damage or rapid part wear to items such as bearings, seals, chains, bushes etc. Caution must be exercised.
- 3 Box set lifting eye profile - these profiles are provided for easy removal of the dual boxes from the pedestals. **Do not use when boxes are loaded nor to lift the machine.**

Maintenance & Care

Lubrication Instructions

Your new Duncan Ag Vineyard Seeder will give long and efficient service if given normal care and maintained properly

 **Lubrication Precautions**

Keep the service area clean and dry.

Only service or lubricate the machine when it is stationary and securely supported.

Lubrication Points on the Orchard Seeder

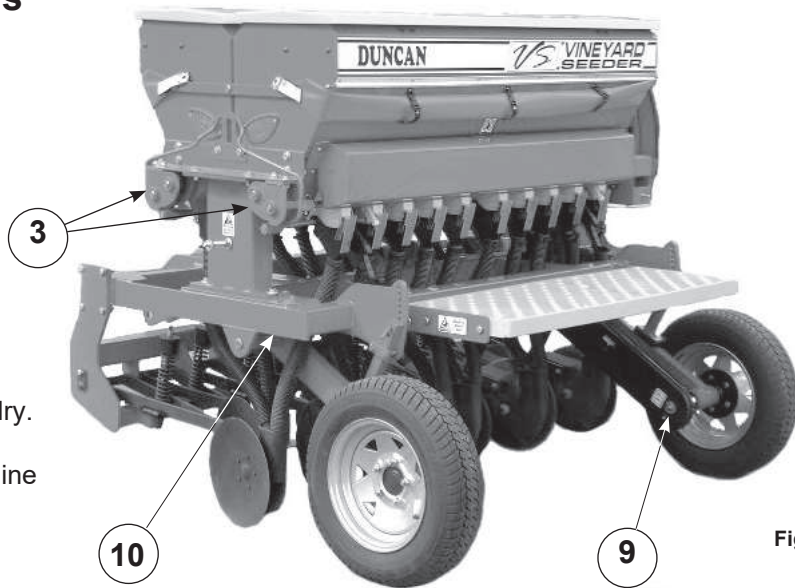
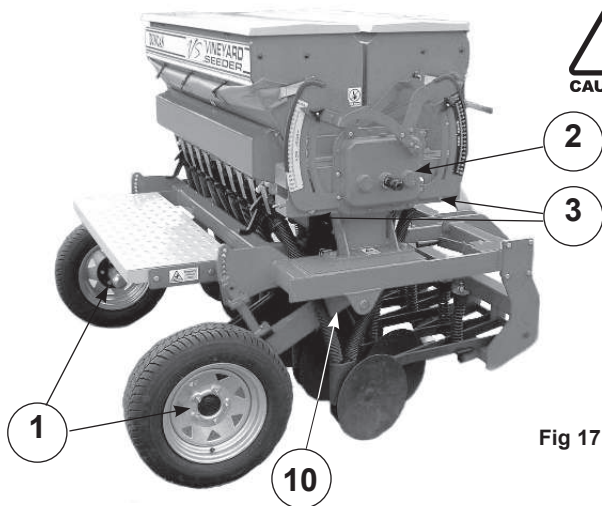

Fig 16



 **Precautions with Grease**

Grease nipples and the grease gun should be carefully cleaned before use to prevent dirt being forced into the bearings.

Dirty grease should be forced from the bushes and disposed of safely.

Greases should not be mixed as the structure may be weakened by the mixing of different types of thickener. This may cause softening and loss of grease from the bearings.

Fig 17

Lubrication Chart

Item	Components	Lubricant	Frequency*
1	Wheel Bearings (2)	Castrol ACX Grease (Refer Page 36)	Annually
2	Gearbox (1)	Castrol Oil Agri Trans Plus (1.25 Litres)	Maintain Level
3	Drive Chains (4)	Suitable Roller Chain Lubricant	6 Monthly
4	Single Discs	Pre-packed & Sealed (Refer Page 38)	Not Required
5	Drive Shafts (Pedestal)	Pre-packed & Sealed (Refer Page 44 & 45)	Not Required
6	Agitator Shaft Supports	Nylon Bushes (Refer Page 50)	Not Required
7	Seeder Shafts	Nylon Supports (Refer Page 52)	Not Required
8	Dragbar Pivots	Acetal Bushes (Refer Page 39)	Not Required
9	Drive Cassettes (8)	Castrol ACX Grease (Refer Page 44)	Weekly
10	Wheel Leg Pivots (2)	Castrol ACX Grease (Refer Page 36)	Weekly

* The lubrication frequencies are only a guide. Actual frequency will be dependent on extent of use and ground conditions.

Maintenance & Care

Maintenance Schedule

Components	Daily (or after 20Ha)	Weekly (or after 75Ha)	Pre Season (or 500 Ha)
Seeders/Agitators/Bottom Flaps	•	•	•
Wheel Nuts		•	•
Wheel Leg Pivots		•	•
Roller Chains		•	•
Drive Cassettes		•	•
	Gearbox (Oil level)		•
<input type="checkbox"/>			
Tyre Pressure (25psi / 1.8bar)		•	•
Wheel Bearings		•	•
Bolted Connections			•
Seed/Fertiliser Tubes			•

1 Bolted Connections

All bolted connections of the machine should be checked after the first 30 hours of operation and retightened if necessary and thereafter at regular intervals. It is suggested that this is done every 500 hectares or annually, whichever occurs first.

2 Gearbox

The oil level in the gearbox can be seen in the oil gauge window (1). Changing the gearbox oil is normally not necessary. For refilling the oil remove the 1/2" BSP plug on the top face of the gearbox (2), Castrol Oil Agri Trans Plus should be used. The total filling capacity is 1.25 litres (refer Fig 18).

DO NOT OVERFILL.

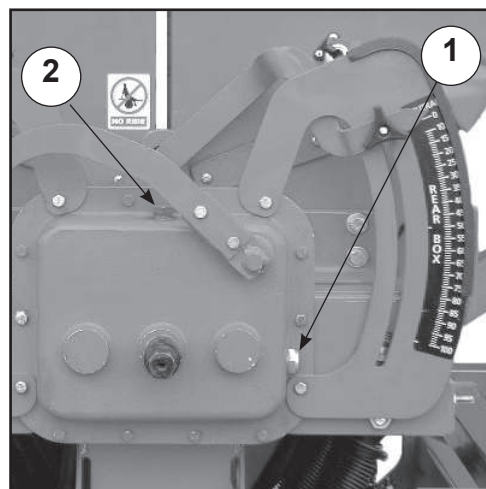

Fig 18

Maintenance & Care

Maintenance Schedule (Continued)

3 Roller Chains

Pedestal and agitator drive chains (1) Fig 19 & (2) Fig 21 should first be checked after 20 hours of operation and thereafter every 200 hours of operation as follows:-

Remove the chain, wash in kerosene and then dip them in heated grease or oil or spray them with a suitable commercial roller chain lubricant.

4 Drive Cassettes

Drive cassettes (2) Fig 19 are fully enclosed and therefore dirt build up around the chain is less likely. A pre-season internal inspection of the drive cassettes is recommended to ensure the chain and sprockets are in good working order. The drive cassettes pivots should be greased weekly to keep the plastic bushes and housings lubricated. Regular greasing will also flush out contaminants from the running surfaces.

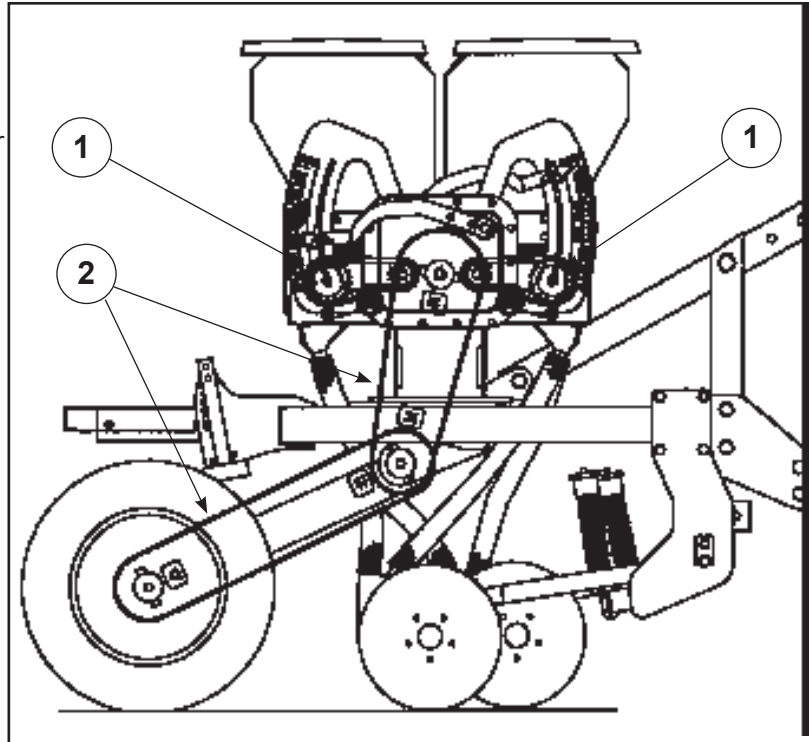

Fig 19

5 Wheel Leg Pivots

Wheel leg pivots (2 per machine) must be greased regularly (weekly or after 75Ha) to provide lubrication and flush out any contaminants.

6 Framework

The framework structure should be inspected annually for defects, i.e., cracks in members or welded connections. The framework should be cleaned prior to the inspection.

7 Tyre Pressure

The recommended tyre pressure is 2.4 bar (35 psi). Check the tyre pressure regularly to ensure correct pressure is maintained. Weekly checks are recommended.

8 Length of Seed/Fertiliser Tubes

These tubes can stretch over a period of time and require checking at approximately six monthly intervals (pre-season). Shorten if necessary to avoid bends which will restrict the flow of seed/fertiliser.

Maintenance & Care

Maintenance Schedule (Continued)

9 Bottom Flaps (Fig 20)

The required seed rate is controlled by both the metering wheels and the bottom flaps. The seed flows from the seed box into the metering wheel housings. Inside the metering wheel housing (1) the seed is caught between the metering wheel (2) and the bottom flap (3). The metered amount of seed is transported by the metering wheel to the edge of the bottom flap where it drops off into the seed guide tube which leads to the coulter. Varying grain sizes require the matching of the flap clearance to the different grain sizes. This matching is done by raising or lowering the bottom flaps by using the flap adjusting lever on the LH end of the seed box. If larger foreign particles, e.g. stones get between the metering wheel and the bottom flap, the bottom flap can give way downwards. A strong return spring (4) brings the bottom flap immediately back into the working position.

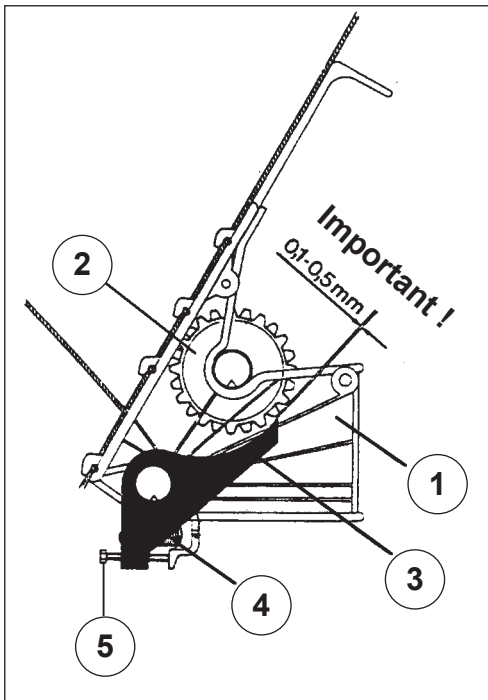

Fig 20

The metering system should be checked every 1/2 year or before any sowing period with an empty seed box and empty metering housings.

Use the following procedure:

Put the bottom flap setting levers (1) (located on the LH end of the seed boxes) in position "1" for the front box and position "1" for the rear box. Refer Fig 21.

By turning the metering wheel shaft by hand check the flaps are all set to a gap of 0.1 to 0.5mm (refer Fig 20). To adjust individual flaps use the spring tensioning screw (5) (Fig 20).

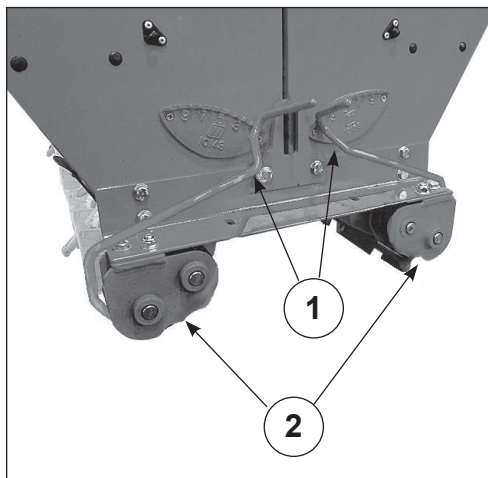

Fig 21

Storage

Preparing the Machine for Storage.

Locate on a dry level surface. The machine should be stored wherever possible with the rams retracted (where fitted). The drive chains should be lubricated with suitable roller chain lubricant before prolonged periods of storage.

For longer term storage remove seed/fertiliser tubes from the coulters and allow to hang without deformation. Check tube lengths when replacing.

It is recommended that maintenance be carried out at the end of the season, giving sufficient time to obtain spare parts and/or carry out repairs if required.

Parts List



Orchard Seeder



Built to work.

Timaru Branch:
100 Hilton Highway, Washdyke,
Timaru, New Zealand
Tel: +64 3 688 2029
Email: timadmin@giltrapag.co.nz
Web: www.giltrapag.co.nz

Australian Branch:
105-117 Boundary Road,
Laverton North, Melbourne,
VIC 3026, Australia
Tel: +61 3 9369 6548
Email: admin@giltrapag.com.au
Web: www.giltrapag.com.au

Pt. No. 67454
Rev 0624

Orchard Seeder Complete Assembly

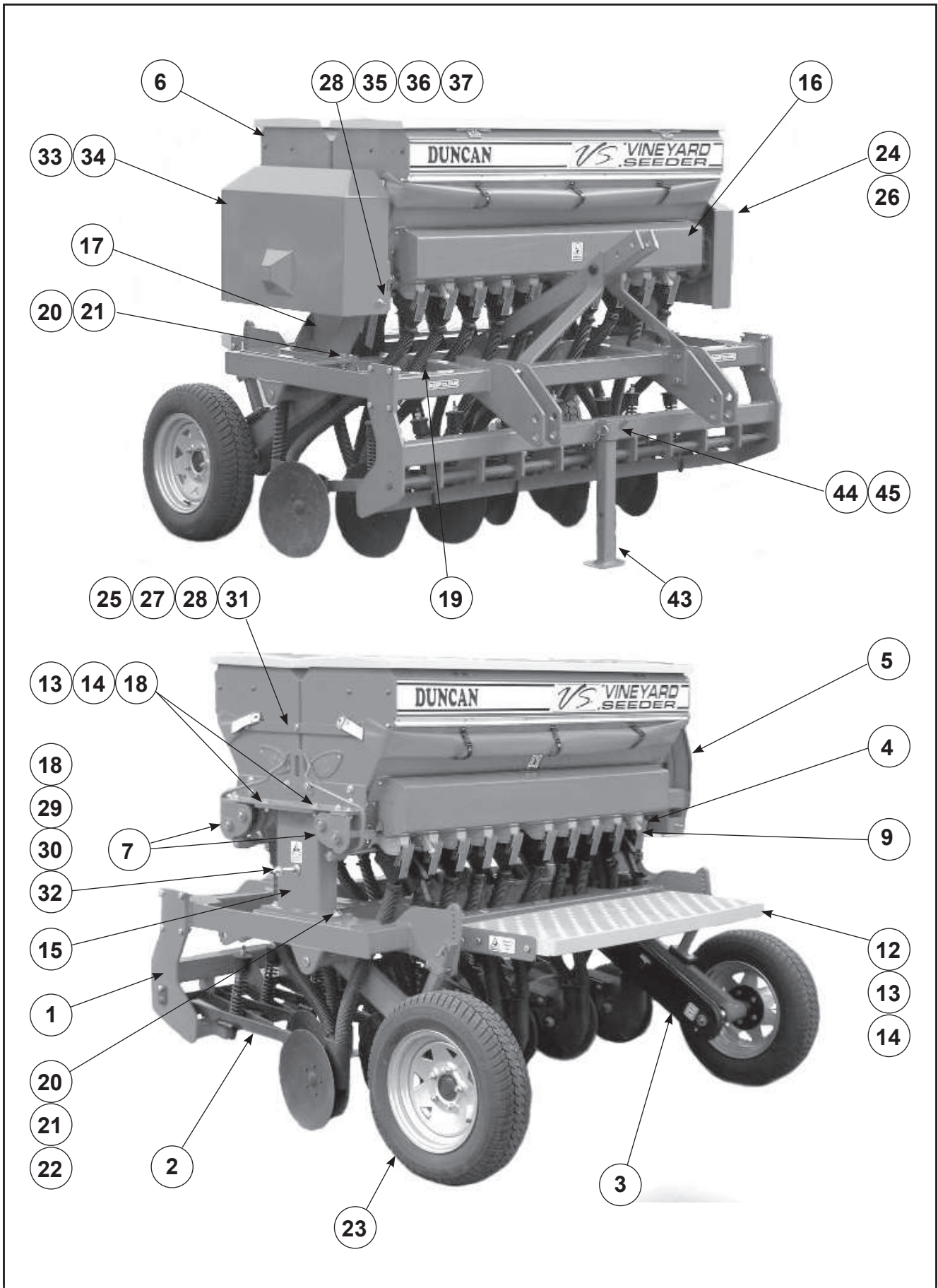

Orchard Seeder Complete Assembly

ITEM	PART No.	DESCRIPTION	QTY
1	Refer Page 34	Main Frame and Wheel Leg Arrangement	1
2	Refer Page 38/39	Dragbar Assemblies	11
3	Refer Page 40	Drive Arrangement	1
4	Refer Page 45	Seedbox Drive Shafts	2
5	Refer Page 46	Gearbox Final Assembly	1
6	Refer Page 48	Seedbox Assembly	2
7	Refer Page 50	Agitator Drives	2
8	Refer Page 51	Agitator Assembly (Inside Seedbox)	2
9	Refer Page 52	Seeder Mechanism	22
10	Refer Page 53	Hectaremeter Kit	1
11	Refer Page 54	Press Wheels	9
12	27770	Footboard Assembly	1
13	45434	M12 x 35 Bolt	8
14	45139	M12 Nyloc Nut	8
15	27750	LH Pedestal Welded Assembly	1
16	27450	10 Run Calibration Tray	2
17	27757	Drive Pedestal Welded Assembly	1
18	45159	M12 H/D Washer	6
19	22051	Crank Arm and Handle Assembly	1
20	45039	M16 x 45 Bolt, Grade 8.8	4
21	45136	M16 Nyloc Nut	4
22	45160	M16 H/D Washer	2
23	43870	Wheel Assembly	2
24	27445	Flap Handle Guard	1
25	27446	Flap Handle Guard Mount	1
26	27396	Flap Handle Guard Trim	2
27	45138	M10 Nyloc	2
28	45152	M10 Plain Nut	4
29	45130	M12 Plain Nut	3
30	45131	M12 Wing Nut	1
31	45433	M10x30 Grade 4.6 ZP Bolt	2
32	45159	M12x115 Threaded Rod	1
33	27394	Gearbox Deflection Guard	1
34	27397	Gearbox Deflection Guard Trim	2
35	45420	M10x35 Grade 4.6 ZP Bolt	2
36	45341	M10 Wing Nut	2
37	45152	M10 Light Flat Washer	4
38	43900	Decal 'No Ride' (50mm x 68mm)	3*
39	43901	Decal 'Pinch Points/Moving Parts' (50mm x 66mm)	4*
40	43902	Decal 'Slippery When Wet' (100mm x 45mm)	2*
41	43905	Decal Arrow (36mm x 24mm)	4*
42	43904	Decal 'Keep Clear' (128mm x 25mm)	2*
43	27375	Jack Stand Assembly	1
44	17439	Jack Lock Pin	1
45	45271	R Clip	1
46	43912	Decal '40 km/hr'	2

***See SAFETY - Machine Specific (Page 11) for Decal Locations**

Orchard Seeder Mainframe & Wheel Leg

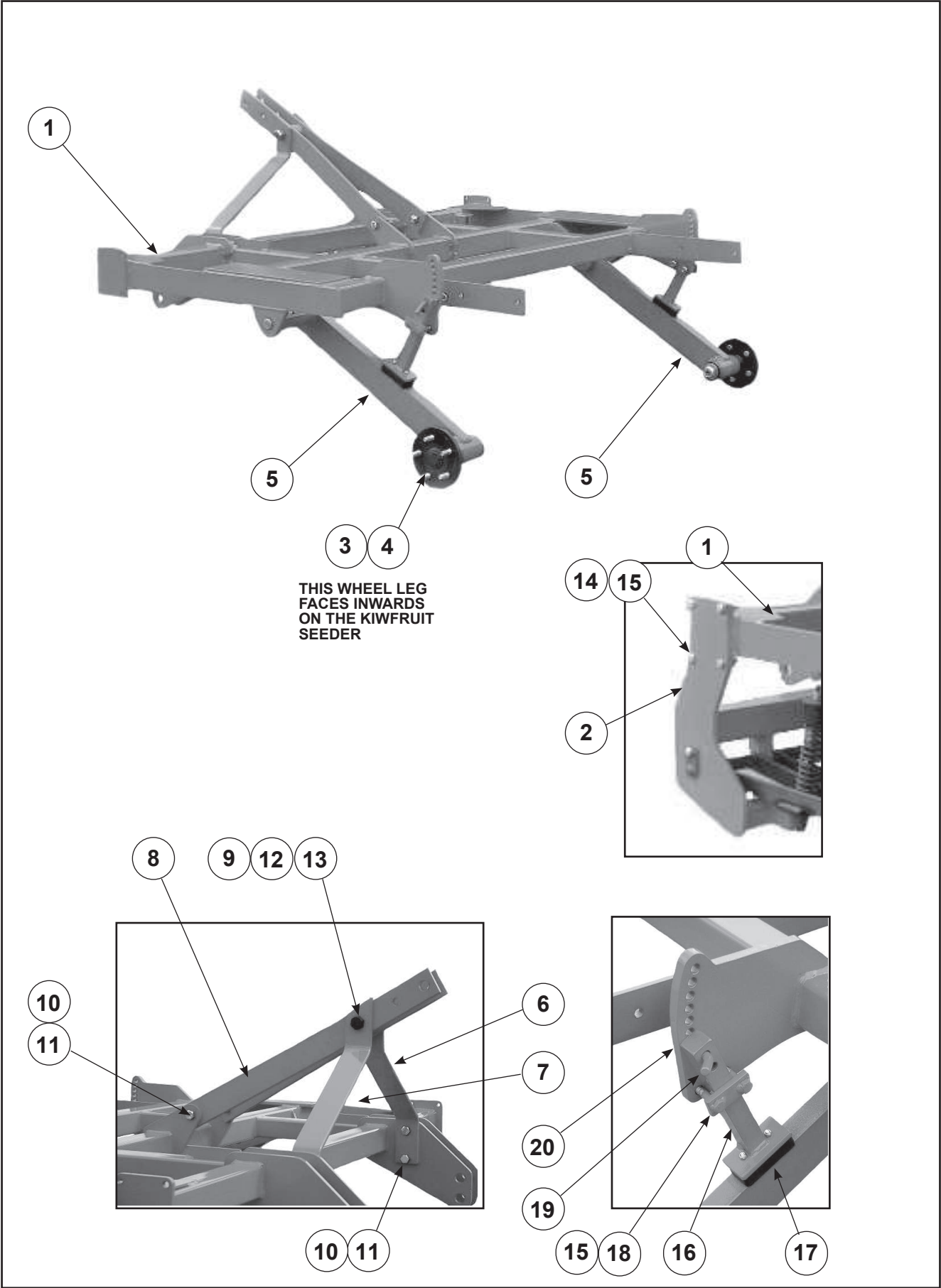

Orchard Seeder Mainframe & Wheel Leg

ITEM	PART No.	DESCRIPTION	QTY
1	74788	Main Frame Assembly (150mm Row Spacing)	1
2	74792-11R	Front Frame Assembly (Double Disc) (150mm 11R)	1
3	18604	Wheel Stud 1/2" x 1 3/4"	8
4	18612	Wheel Nut 1/2"	8
5	Refer Page 36	Wheel Leg & Axle Assemblies	2
6	21467	L/H Link Support Stay	1
7	21468	R/H Link Support Stay	1
8	27455	Rear Link Support Stay	2
9	27778	Top Link Spacer	1
10	45039	M16 x 45 Bolt Class 8.8	6
11	45140	M16 Nyloc Nut	6
12	47237	7/8" x 5 1/2" UNF Bolt	1
13	47548	7/8" UNF Nyloc Nut	1
14	45435	M12 x 40 Bolt	8
15	45139	M12 Nyloc Nut	12
16	21451	Wheel Retraction Stop	2
16	27738	Wheel Retraction Stop (Alternative)	2
17	11760	Buffer Block (Complete with M6 Nyloc)	2
18	19093	Clamp Plate Assembly	2
19	16164	Pin	2
20	45271	R Clip	1

Note: Item 16 (27738) is available to give greater lift (70mm approximately)

Orchard Seeder Wheel Leg & Axle Assembly

ITEM	PART No.	DESCRIPTION	QTY
1	27732	Drive Wheel Leg Assembly	1
2	27733	Non-Drive Wheel Leg Assembly	1
3	27740	Drive Leg Axle Welded Assembly	1
4	27741	Non-Drive Leg Axle Welded Assembly	1
5	19064	Plastic Bush	4
6	17910	Wheel Bearing	4
7	18611	Axle Oil Seal	3
8	43118	M8 x 1.25 Pitch Grease Nipple Straight	-
9	11361	Hub Cap	1
10	45143	M24 H/D Flat Washer	1
11	27743	Drive Axle Spacer	1
12	27747	Leg Pivot Shaft	2
13	45186	M10x12 S/H Grub Screw	2
14	45141	M24 Nyloc Nut	2



Orchard Seeder Double Disc Dragbars

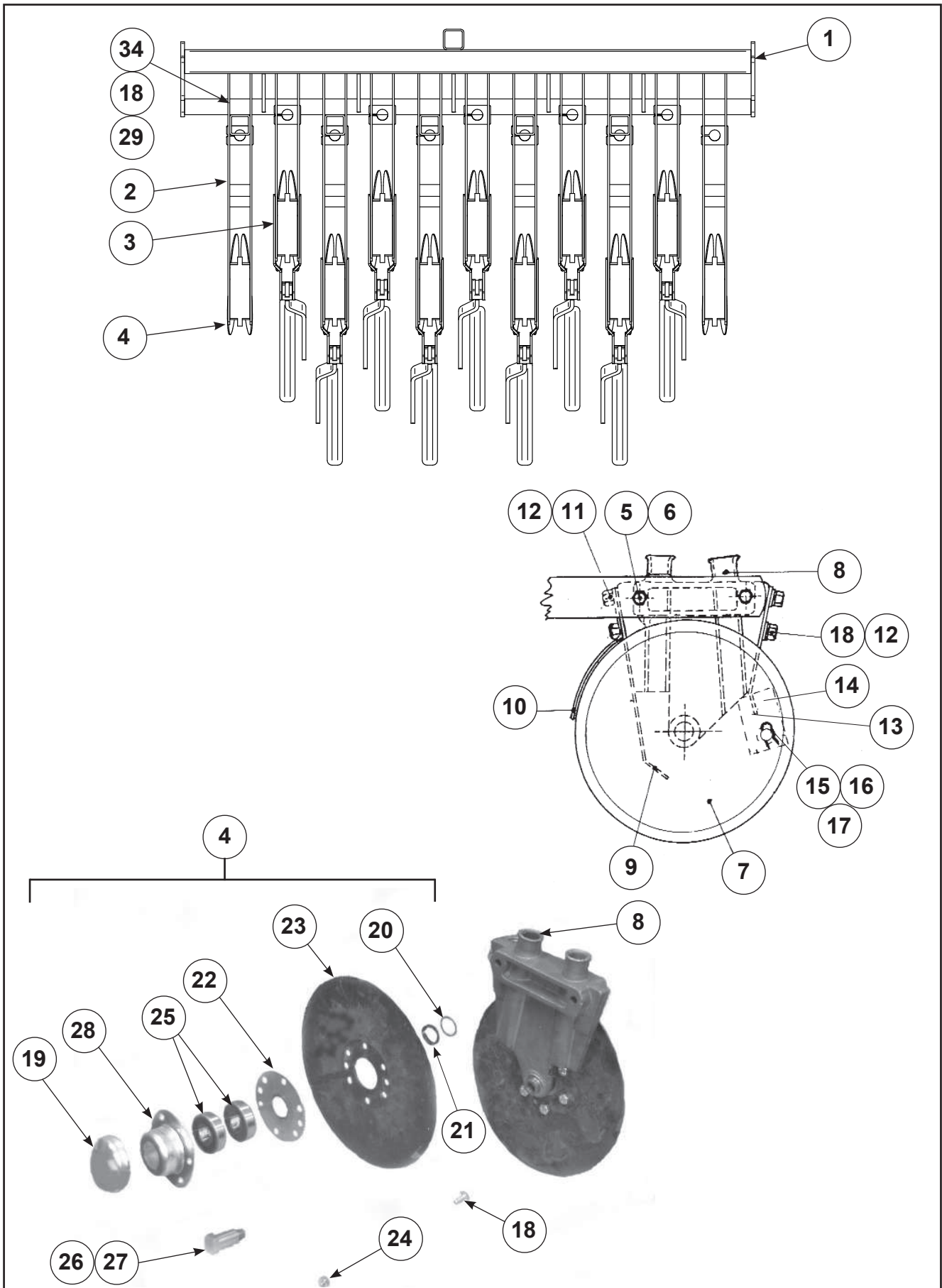

Orchard Seeder Double Disc Dragbars

ITEM	PART No.	DESCRIPTION	QTY
1	74792-11R	Front Frame Assembly (Double Disc) (150mm 11R)	1
2	27790	Dragbar Assy. Long	6
3	27795	Dragbar Assy. Short	5
4	27766	Double Disc Coulter Assy	11
5	45445	M12 x 100 Bolt	-
6	45139	M12 Nyloc Nut	-
7	11520	Double Disc Assy LH	-
7	11521	Double Disc Assy RH	-
8	27767	Double Disc Coulter Body	-
9	11389	Seed Deflector	-
10	11388	Front Guard	-
11	45418S	M10 x25 Set Screw	-
12	45166	M10 Spring Washer, Zinc plated	-
13	11551	Scraper Carrier	-
14	11550	Scraper Blade	-
15	11553	Scraper Rod	-
16	11552	Spring	-
17	45271	'R' Clip	-
18	45417S	M10 x 20 Set Screw	-
19	11361	Hub Cap	-
20	27768	Spacer Washer	-
21	43893	Vee Ring Seal V30A	-
22	17427	Seal Face Ring	-
23	11549	12,5" Plain Disc 6 Hole	-
24	45138	M10 Nyloc Nut	-
25	11351	Bearing	-
26	11362	Axle Bolt LH	-
27	11363	Axle Bolt RH	-
28	18364	Bearing Housing , 6 Hole	-
29	43361	Acetal Bush	-
30	27773	Spring Rod	-
31	27774	Spring	-
32	27370	Spring Cap	-
33	45131	M12 Plain Nut	-
34	27377	Dragbar Axle Assy	-
35	43691A	38mm Nylaflow Air Seeder Hose (per metre)	-

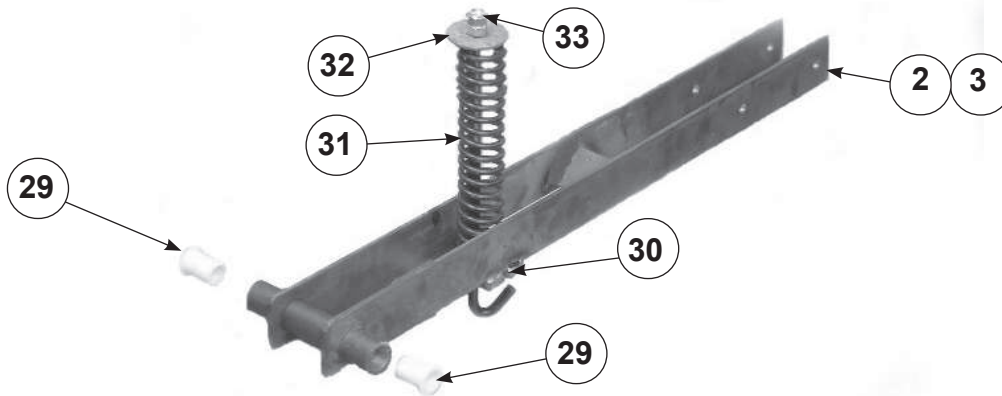

Orchard Seeder Complete Drive Arrangement

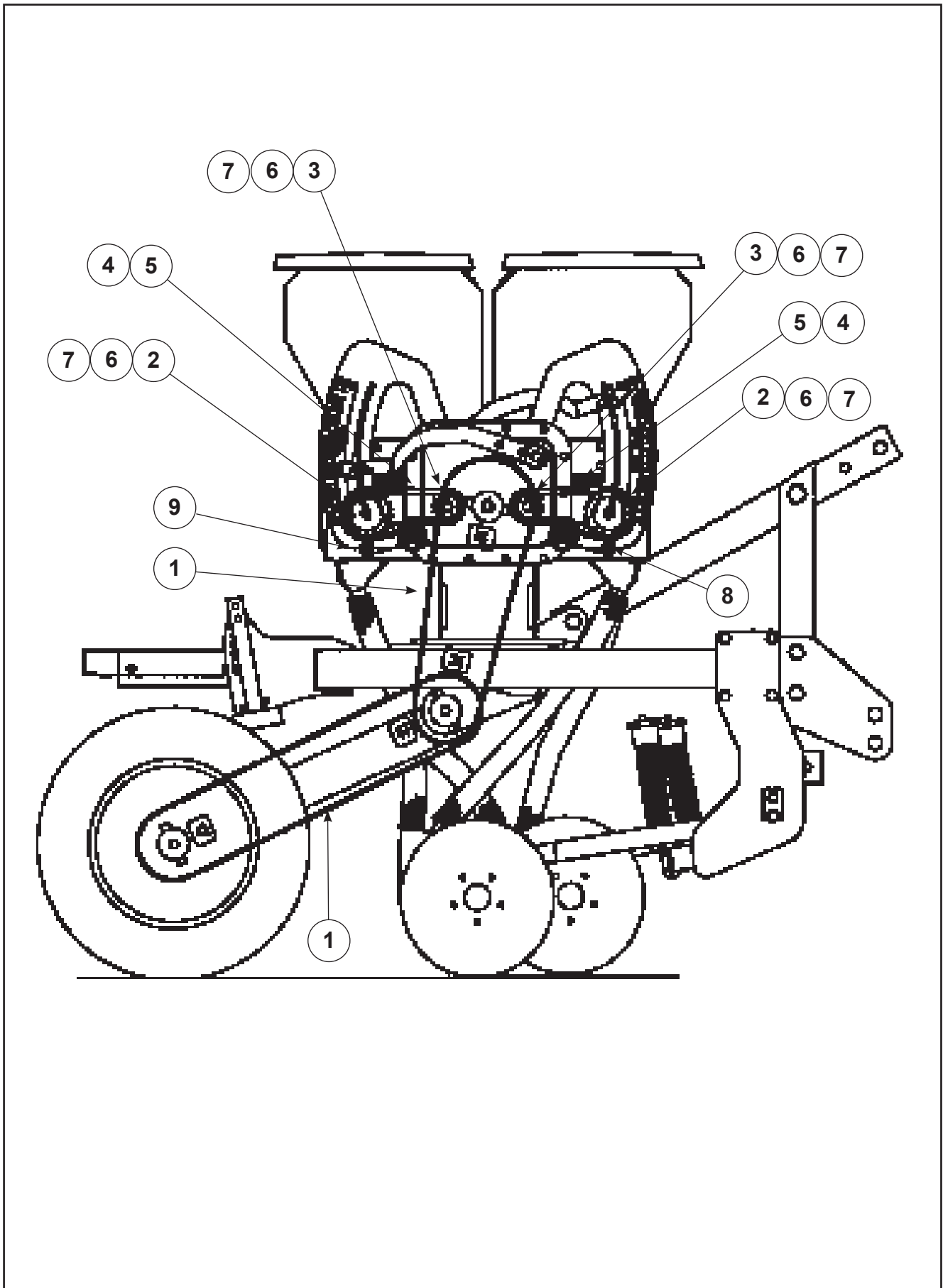

Orchard Seeder Complete Drive Arrangement

ITEM	PART No.	DESCRIPTION	QTY
1	Refer Page 44	Gearbox Input Drive System	1
2	22537	25 T Sprocket 1/2" P x 20mm Bore (Also See 'Seed Box Drive Shafts')	2
3	22044	15 T Sprocket 1/2" P x 20mm Bore	2
4	43388	1/2" Pitch Joining Link	2
5	25780	1/2" BS Chain x 47 Links (Gearbox to Boxshaft)	2
6	22294	Sprocket Key (6 x 6 x 25)	4
7	45180	M8 x 10 Socket Head Grub Screw	8
8	Refer Page 42	Front Box Shaft Chain Tensioner	1
9	Refer Page 43	Rear Box Shaft Chain Tensioner	1

Orchard Seeder Front Box Shaft Chain Tensioner

ITEM	PART No.	DESCRIPTION	QTY
1	22535	Nylon Roller	1
2	22480	RH Arm Assembly	1
3	22522	LH Torsion Spring	1
4	23376	Chain Tensioner Anchor	1
5	45132	M16 Half Nut	1
6	45461	M16x65 Bolt	1

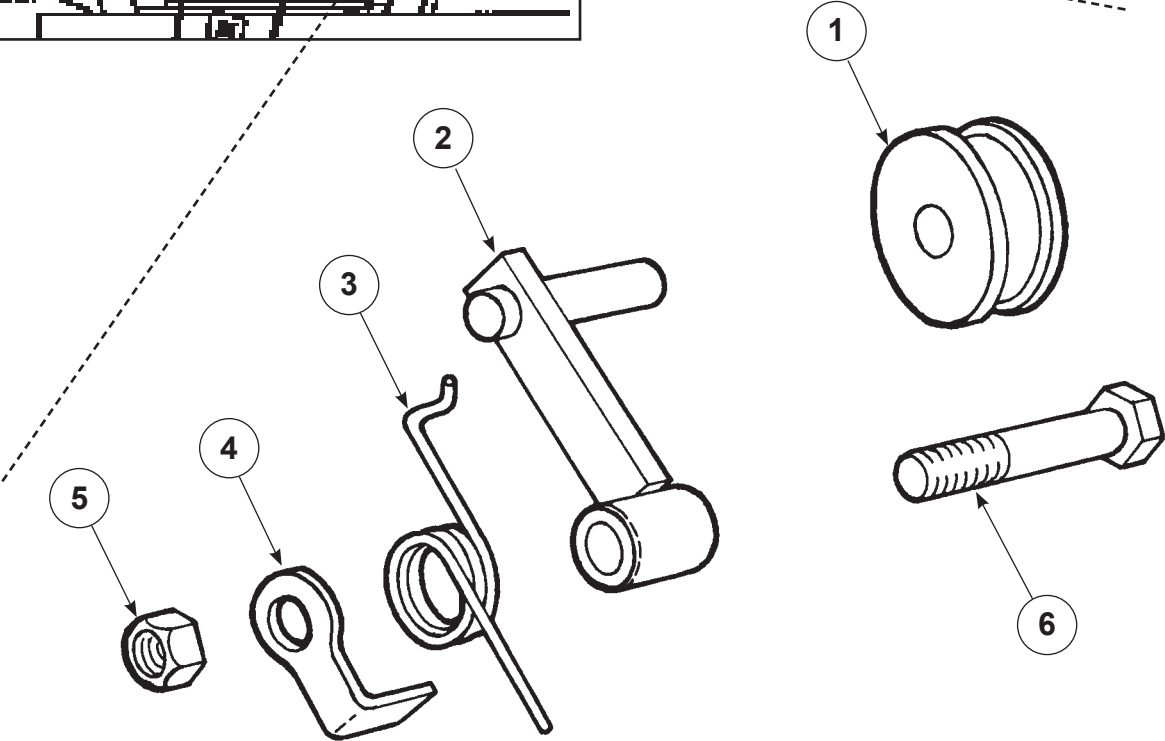
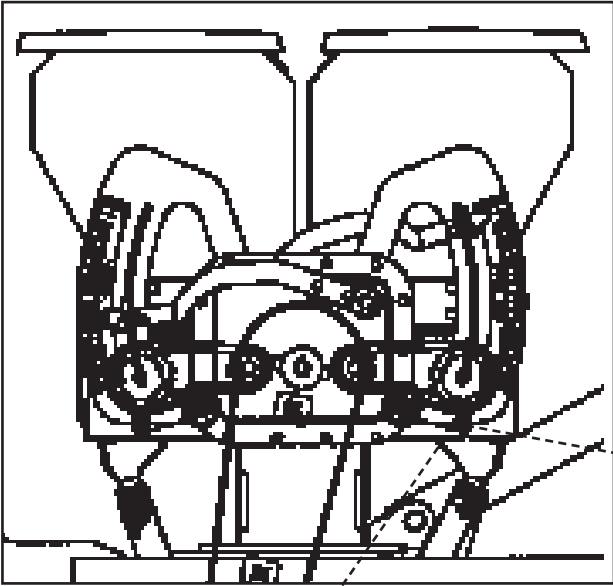

Orchard Seeder Rear Box Shaft Chain Tensioner

ITEM	PART No.	DESCRIPTION	QTY
1	22535	Nylon Roller	1
2	22480	RH Arm Assembly	1
3	22523	RH Torsion Spring	1
4	23376	Chain Tensioner Anchor	1
5	45132	M16 Half Nut	1
6	45461	M16x65 Bolt	1

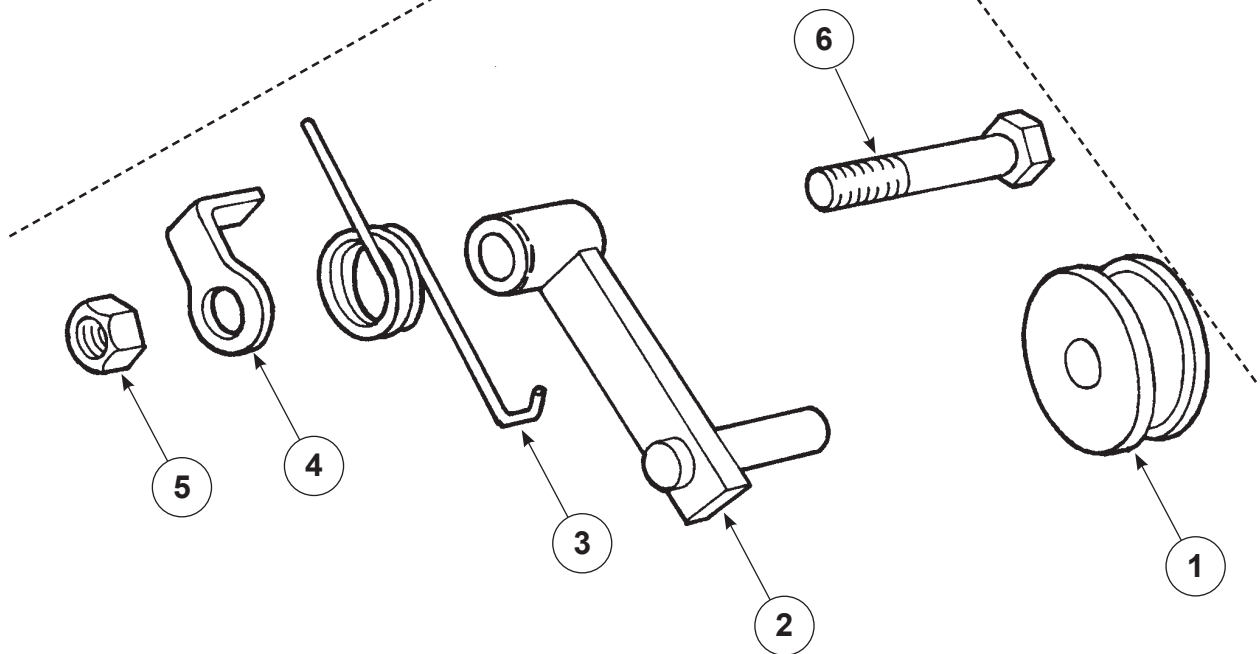
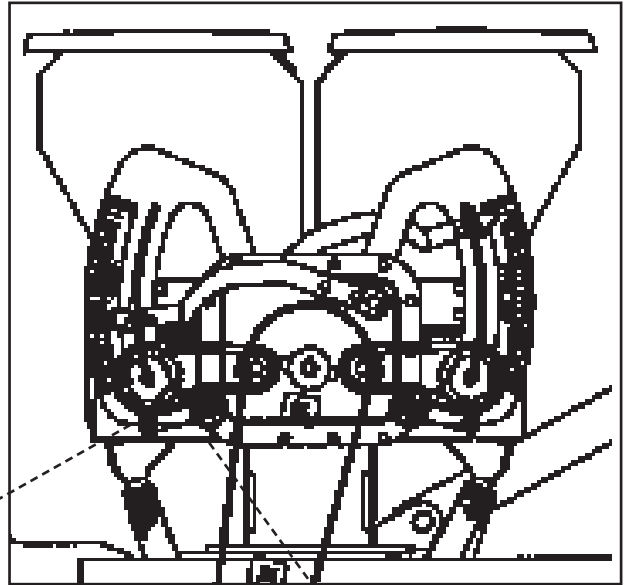

Orchard Seeder Gearbox Input Drive System

ITEM	PART No.	DESCRIPTION	QTY
1	74947	Hex Drive Shaft (short) Note: Left Hand Thread	1
2	74227	29T/29T 442 Crs Drive Cassette	1
3	27764	Hexagonal Transfer Drive Shaft	1
4	74236	23T/29T 635 Crs Drive Cassette	1
5	74948	Cassette Hex Drive Shaft	1
6	27737	Cassette Drive Spacer	1
7	27762	Short Transfer Shaft	1
8	27344	Transfer Shaft Connecting Sleeve	1
9	30359	Bearing Housing PF52 (2 Flanges = 1 Housing)	1
10	43386	"Y" Bearing YET205 (25mm)	1
11	45180	M8 x 10 S/Head Grub Screw	4
12	45411s	M8 x 20 Z/P Set Screw	3
13	45137	M8 Nyloc Nut	3
14	72913	Sensor Mount Bracket	1
15	11652	Proximity Sensor	1
16	72951	Prox Trigger	1
17	48036	Dia. 14-27mm Hose Clip Stainless	1
18	45417s	M10 x 20 Z/P Bolt	1
19	45138	M10 Nyloc Nut	1
20	45272	R Clip	4
21	45155	M20 Light Flat Washer	4

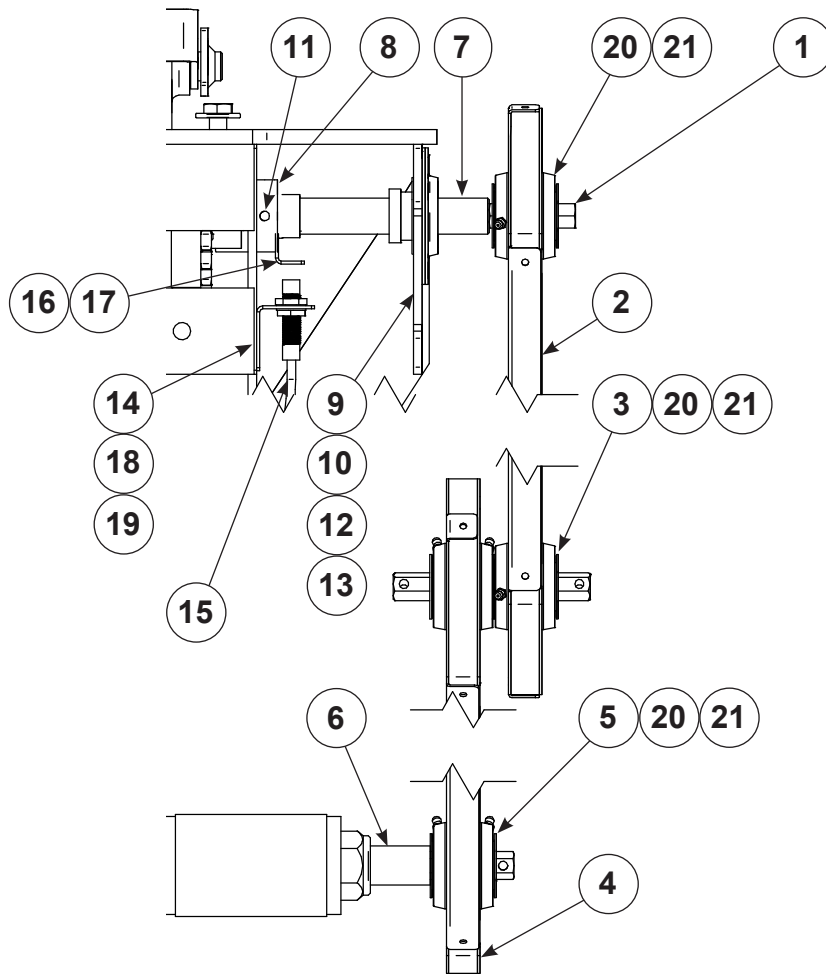

Orchard Seeder Seed Box Drive Shafts

ITEM	PART No.	DESCRIPTION	QTY
1	22537	Sprocket, 25T x 1/2" Pitch, 20mm Bore	1
2	22294	Key, Sprocket 6 x6 x 25	1
3	25758	Shaft, Box Drive	1
4	43385	"Y" Bearing, YET 204, 20mm	2
5	43387	Housing, Bearing, Press Steel, PFT47 (2 Flanges = 1 Housing)	2
6	45137	Nut, M8, Nyloc	4
7	45181	Grubscrew, M8 x 12, Socket Head	2
8	45411S	Set Screw, M8 x 20, Zinc Plate	4
9	-	Locking Collar (Part of item 4 and not supplied separately)	2

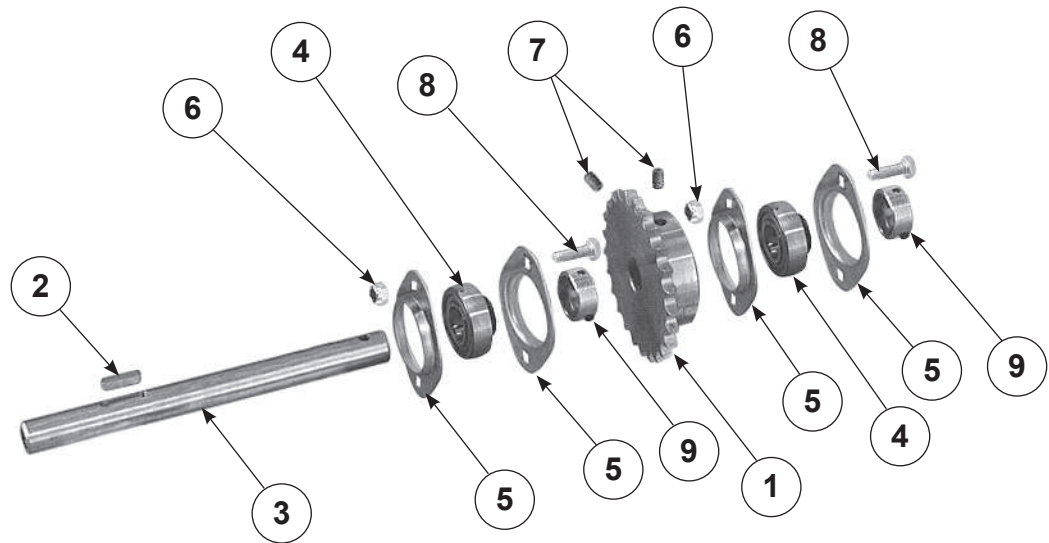

Orchard Seeder Gearbox Final Assembly

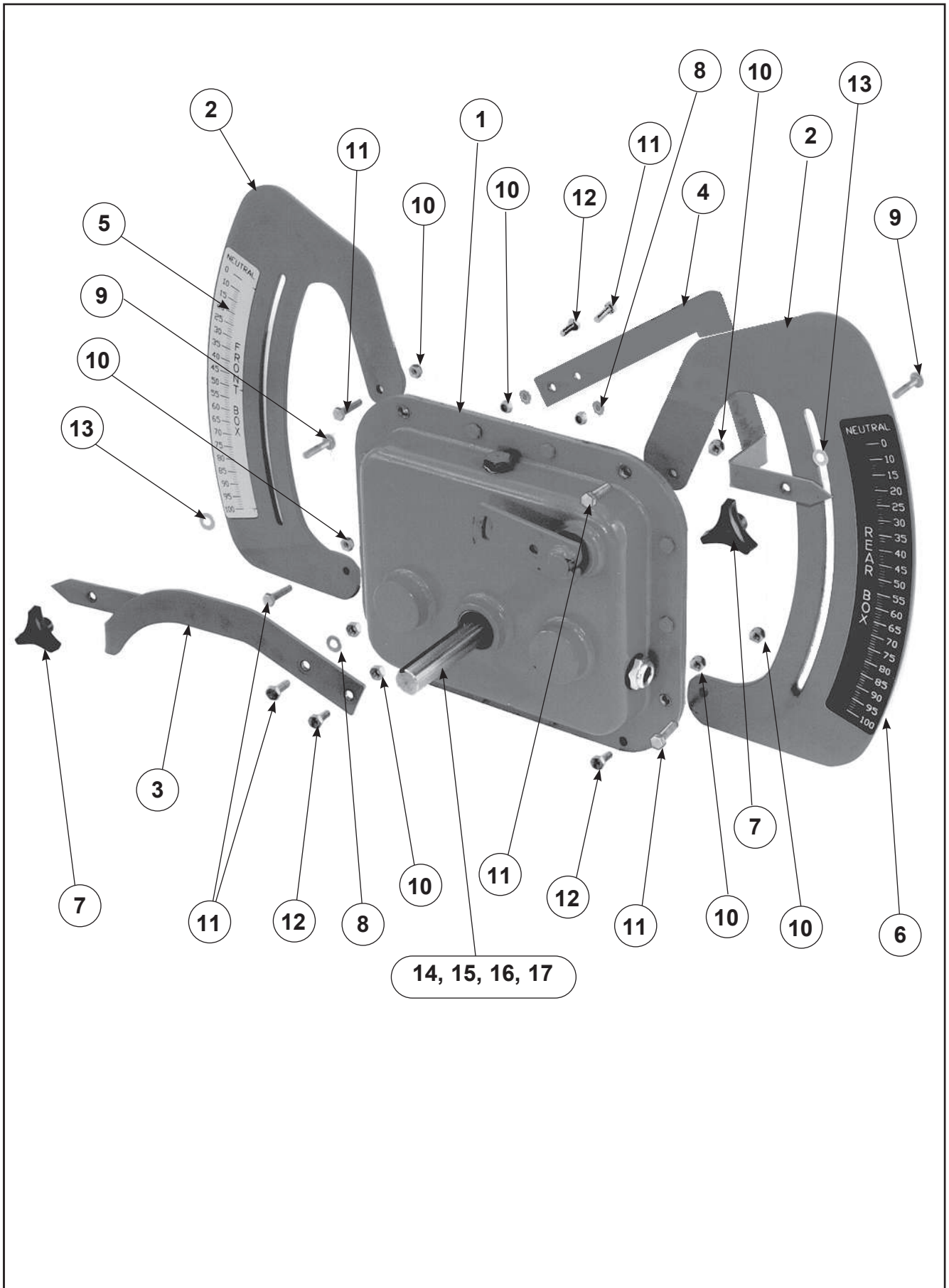

Orchard Seeder Gearbox Final Assembly

ITEM	PART No.	DESCRIPTION	QTY
1	25756	Gearbox Sub-Assembly	1
2	22036	Quadrant, Speed Adjusting	2
3	25754	Lever, Front, Speed Adjusting	1
4	25755	Lever, Rear, Speed Adjusting	1
5	22041	Label, Front, Speed Indicator	1
6	22042	Label, Rear, Speed Indicator	1
7	43366	Tri-Knob, M8, Tapped Centre	2
8	45157	Washer, Flat, M8, Heavy Duty, Zinc Plate	2
9	47031	Bolt, Coach, M8 x 40 Cup Head, Class 4.6, Zinc Plated	2
10	45137	Nut, M8 Nyloc	8
11	45399	Bolt, M8 x 30 Class 4.6, Zinc Plated	6
12	45411S	Bolt, M8 x 20 Class 4.6, Zinc Plated	12
13	45151	Washer, Flat, M8, Light	2
14	25762	Gearbox Final Assembly (Includes items 1 to 13 and items 15, to 17)	1
15	27341	Crank Adaptor (Not Illustrated)	1
16	22294	Sprocket Key (Not Illustrated)	1

Orchard Seeder Seedbox Assembly

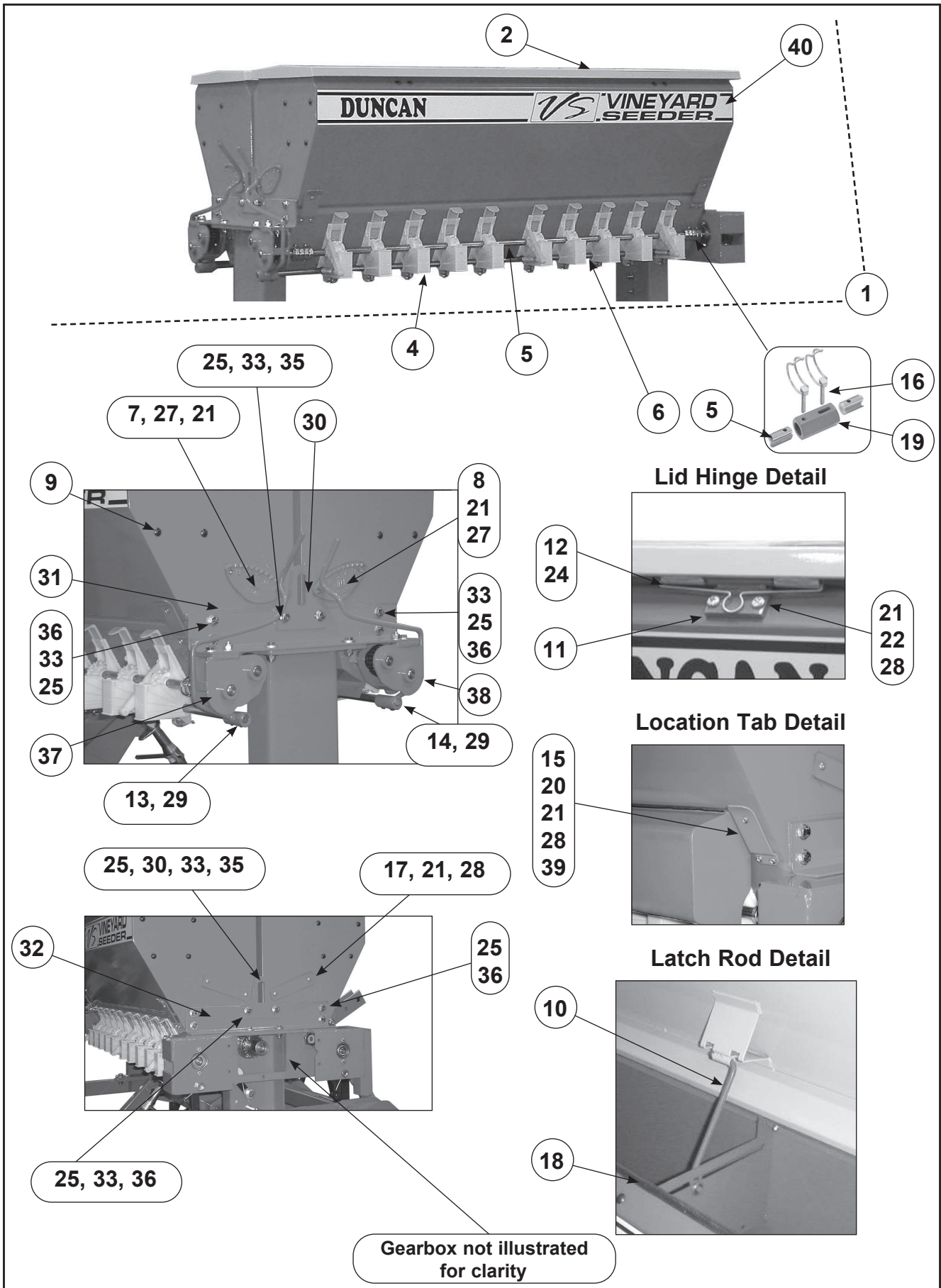

Orchard Seeder Seedbox Assembly

ITEM	PART No.	DESCRIPTION	QTY
1	27400-11R	11R Box Complete Assembly	1
2	27410-11R	11R Box with Lid	2
3	Refer Page 51	Agitator Assembly (Inside Box)	2
4	Refer Page 52	Seeder Assembly	20
5	27420	Box Shaft (20mm)	2
6	27430	Flap Shaft (18mm)	2
7	10143	Front Box Quadrant Plate	1
8	10158	Rear Box Reverse Quadrant Plate	1
9	14442	Rubber Body Plug R187	28
10	22487-11R	Latch Rod Assembly	2
11	22490	Hinge Assembly	4
12	22491	Hinge Pin	4
13	25708	Front Flap Handle Assembly	1
14	25709	Rear Flap Handle Assembly	1
15	22568	Location Tab (Calibration Tray)	4
16	47615	6 x 40 Pipe Lynch Pin	8
17	22855	Agitator Access Blanking Plate	2
18	43373	Black Edge Trim (1.5m)	2
19	23633	Box Shaft Short Connecting Sleeve	4
20	45122	M6 Class 8.8 Zinc Plated Hex Nut	4
21	45136	M6 Nyloc Nut	32
22	45150	M6 Zinc Plated Light Flat Washer	8
23	-	-	-
24	27599	Hinge Pin Spring Clip	4
25	45139	M12 Nyloc Nut	24
26	45702	4.8 x 9.5 Monel Pop Rivet	8
27	45758	M6 x 16 Zinc Plated Countersunk Posidrive Screw	4
28	45908	M6 x 16 Zinc Plated Pan Head Machine Screw	20
29	45186	M10 x 12 Socket Head Grubscrew	4
30	22485P	Box Set Lifting Eye Profile	2
31	25759	Box Set Mounting Bracket LH	1
32	25760	Box Set Mounting Bracket RH	1
33	45153	M12 Zinc Plated Light Flat Washer	32
35	45435S	M12 x 40 Set Screw	4
36	45433S	M12 x 30 Set Screw	12
37	Refer Page 50	Front Agitator Drive Assembly	1
38	Refer Page 50	Rear Agitator Drive Assembly	1
39	45907	M6 x 12 Pan Head Pozi Drive M/C Screw	12

Orchard Seeder Agitator Drives

ITEM	PART No.	DESCRIPTION	QTY
1	22414	Agitator Drive Rear Housing	1
2	22415	Agitator Drive Front Housing	1
3	22416	Agitator Drive Spacer	2
4	22418	3/8" Pitch x 20mm Bore 21T Sprocket	2
5	22422	3/8" Pitch x 20mm Bore 15T Sprocket	2
6	22417	3/8" Pitch x 33 Link BS Chain	2
7	43396	3/8" Pitch Joiner Link	2
8	22425	Agitator Shaft Extension	2
9	22426	Seed Shaft Extension	2
10	43428	Nylon Bush	6
11	22419	Box Shaft Connecting Sleeve (long)	4
12	22420	Agitator Shaft Joining Collar	2
13	45415	M8 x 45 Class 4.6 Zinc Plated Bolt	2
14	45416	M8 x 60 Class 4.6 Zinc Plated Bolt	2
15	45137	M8 Nylock Nut	4
16	45180SS	M8 x 10 Stainless Steel Socket Head Grub Screw	4
17	47615	6 x 40 Pipe Lynch Pin	4

***Quantities shown are sufficient for one rear end and one front agitator assembly**

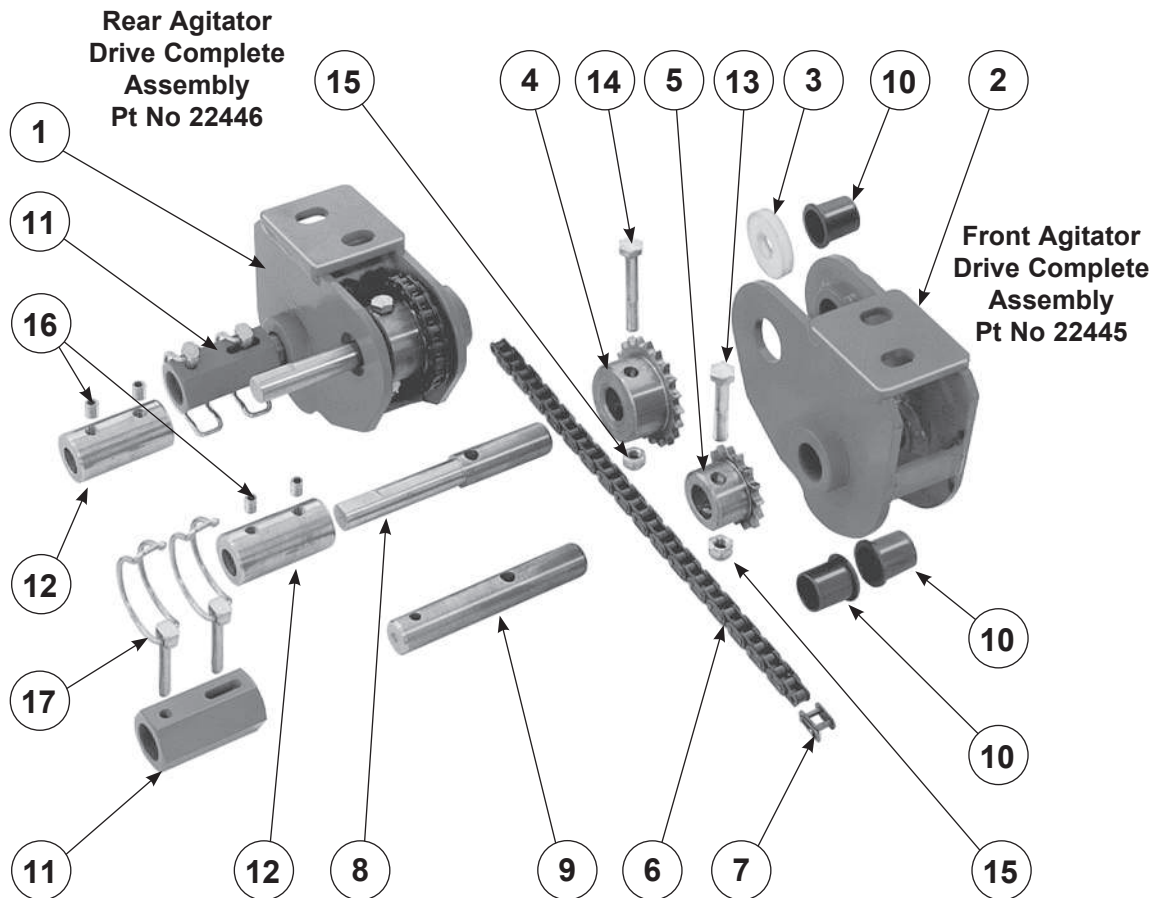

Front assembly only shown exploded

Orchard Seeder Agitator Assembly

ITEM	PART No.	DESCRIPTION	QTY
1	27440	Agitator Shaft Assembly	1
2	22420	16mm Agitator Joining Collar	1
3	22423	Agitator Shaft Support RH (Short)	1
4	22424	Agitator Shaft Support LH (Long)	1
5	22428	Agitator Shaft Support Cap	1
6	43442	5/8" Lurethane Wiper Seal	2
7	45185SS	M10 x 10 Stainless Steel Socket Head Grubscrew	2
8	45410SSS	M8 x 16 Grade 316 Stainless Steel Set Screw	2
9	45137SS	M8 Grade 316 Stainless Steel Nyloc Nut	2
10	47600	M30 ISO Fine Zinc Plated Hex Lock Nut	2

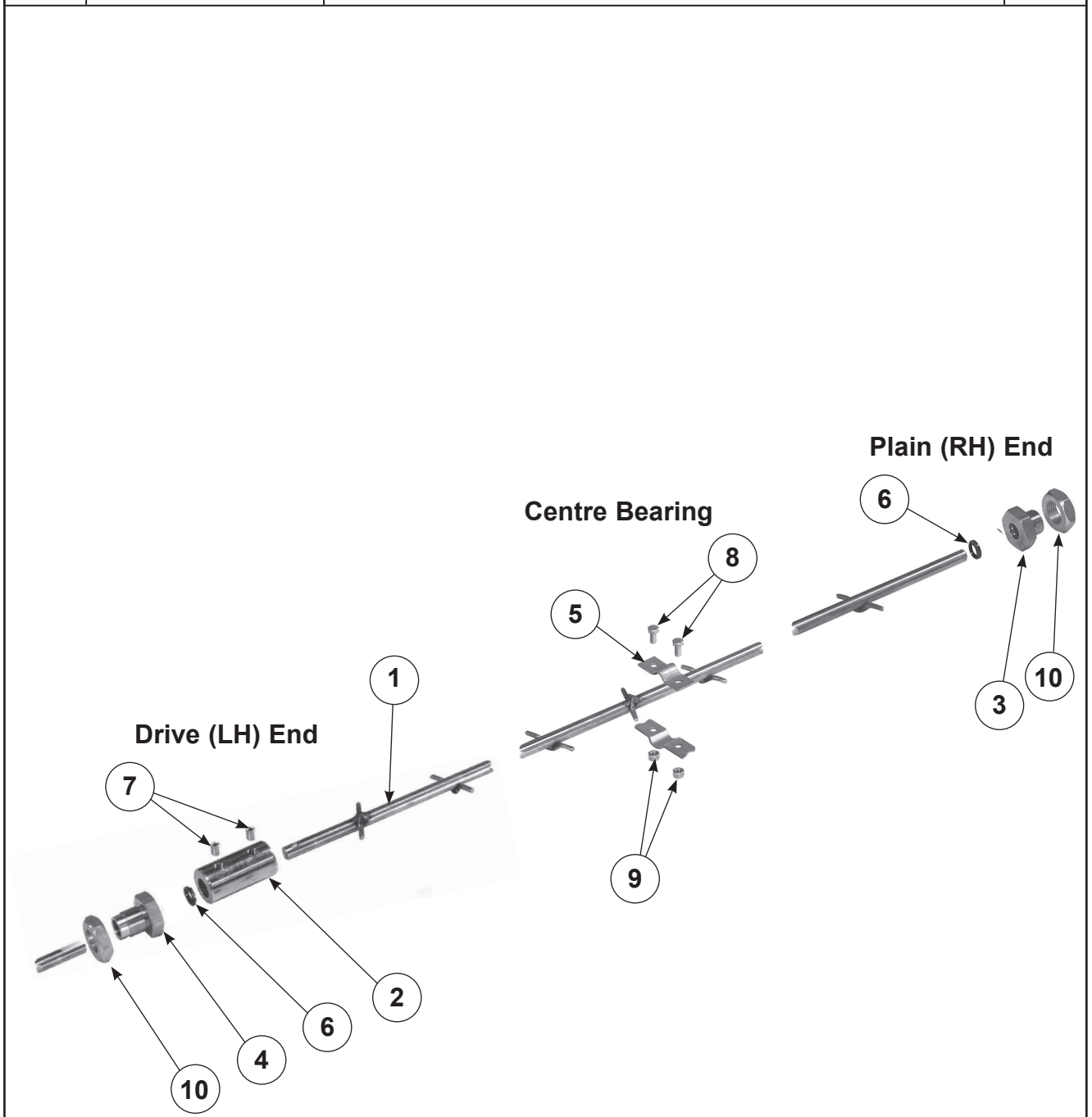

Orchard Seeder Seeder Mechanism

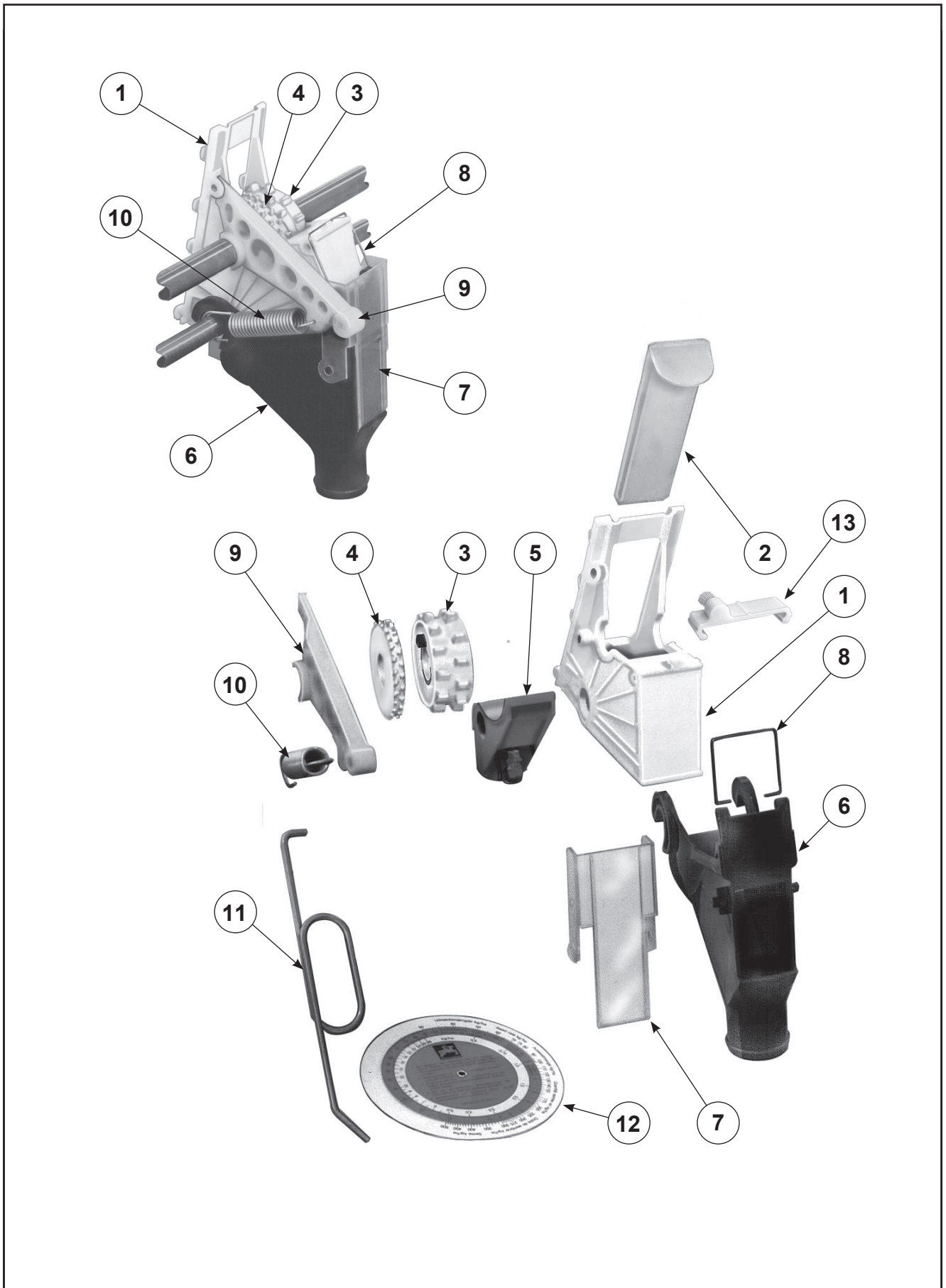

Orchard Seeder Seeder Mechanism

ITEM	PART No.	DESCRIPTION	QTY
1	43375	Metering Housing	22
2	43376	Shutter Slide	22
3	43377	Seed Metering Wheel Assembly (Includes item 4)	22
4	43374	Fine Seed Wheel (For Spares Ordering Only)	-
5	43378	Bottom Flap & Bolt Assembly	22
6	22550	Seeder Extension Funnel	22
7	22551	Seed Diverter	22
8	22548	Spring Clip, S/S	22
9	43379*	Seed Shaft Guide Bearing	4
10	43380*	Guide Bearing Tension Spring	4
11	43382*	Metering Wheel Clutch Hook	1
12	43383*	Seed Rate Disc Calculator	1
13	43362	Fine Seed Wheel Brush (Optional Extra)	-

*Items not on all Seeder mechanism assemblies

Orchard Seeder Hectaremeter Kit

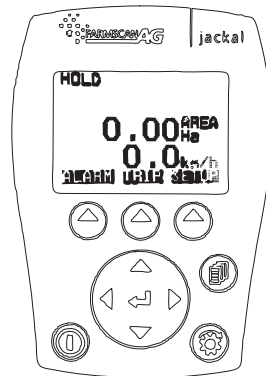

ITEM	PART No.	DESCRIPTION	QTY
KIT	44571K	Contains the following:	
1	44572	Jackal Basic Speed & Area Meter	1
2	44573	Owner's Manual Jackal	1
3	44028	Window Mount AH-407	1
4	48027	7.5m Cable (3 way)	1
5	11652	Prox Sensor	1
6	48177	Cable S/Assy (1 x 3way + power)	1
<i>Individual items from 48177 listed below:</i>			
7	44029	Power Cable	1
8	44146	11 way Terminal Block P321 Green	1
9	44567	11 way Terminal Block P322 Grey	1
10	48178	3 Way Short Cable	1

Orchard Seeder Press Wheel Arrangement

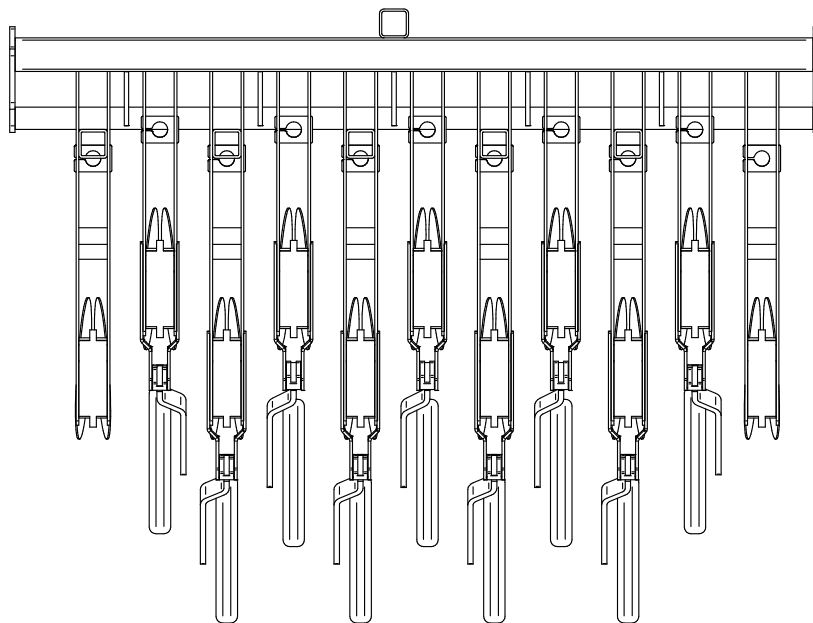
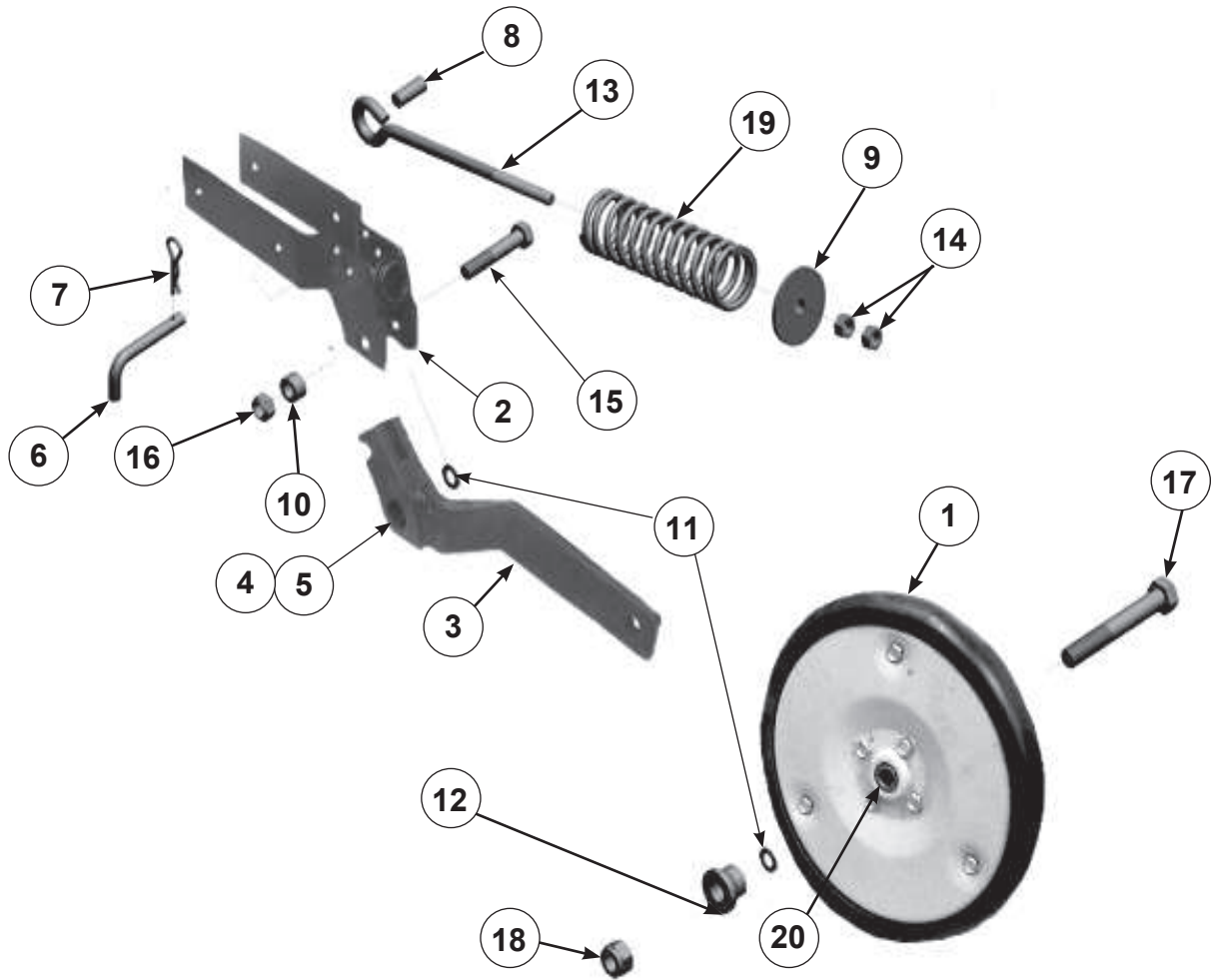

Orchard Seeder Press Wheel Arrangement

ITEM	PART No.	DESCRIPTION	QTY
1	43880	13" x 48mm Press Wheel	1
2	27805	Press Wheel Mount Assy	1
3	27800	LH Press Wheel Arm Assy	1
3	27802	RH Press Wheel Arm Assy	1
4	43872	Bearing	2
5	26890	Bearing Spacer 16.5mm	1
6	26898	Transport Pin	1
7	45271	'R' Clip	1
8	26892	Eye Bolt Retention Pin	1
9	26886	Spring Cap	1
10	26887	Spacer 12mm	1
11	26888	M12 Washer	2
12	26893	Inner Spacer	1
13	26897	M10 Eye Bolt	1
14	45130	M10 Hex Nut	2
15	45026	M12 x 65 Grade 8.8 Bolt	1
16	45139	M12 Nyloc Nut	1
17	45048	M16 x 100 Grade 8.8 Bolt	1
18	45140	M16 Nyloc Nut	1
19	26891	Spring	1
20	43306	Bearing 203502	1

Note: The right hand press wheel system is identical to the left hand one (shown), except for the hand of the arm assembly. Note the location of the right hand press wheel system on the layout.

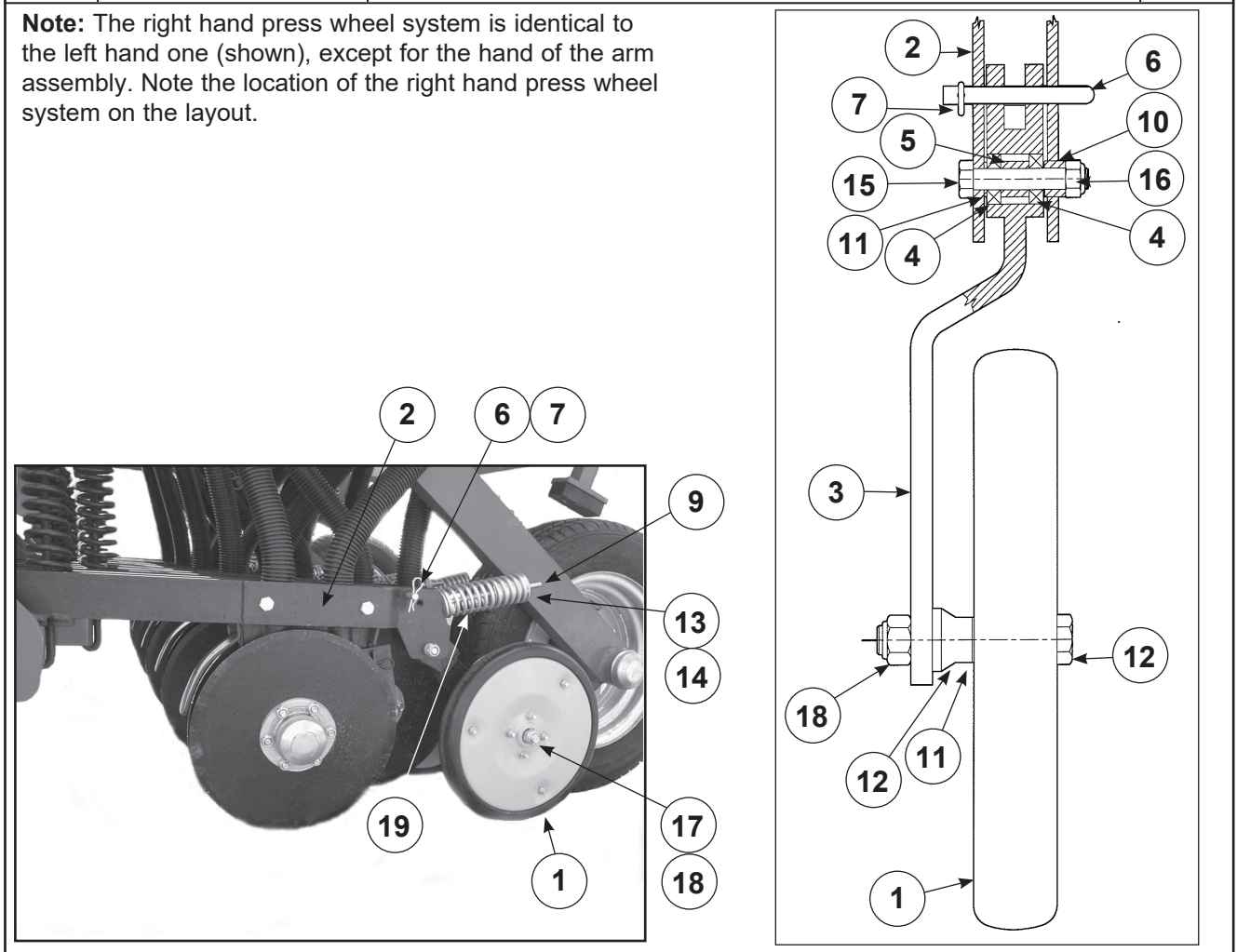

Note: Press wheel arrangement available only for double discs

Pt. No. 67454
Rev 0624

