

65 YEARS

100%
MADE IN
NZ



Giltrap Multiplus

Operation & Parts Manual



Disclaimer

While every attempt has been made to ensure that information and diagrams in this manual are correct, Giltrap Engineering Limited will not be responsible for any damage or consequential loss arising out of misinterpretation or failure to follow recommended procedures; nor will it be liable for any damage caused by or arising out of modification or misuse of its product.

For parts or service enquiries, please use the applicable contacts on the previous page.

Printed May 2021

Copyright © 2021 by Giltrap Engineering Ltd.
Printed in New Zealand

All rights reserved. Reproduction or use, without express permission, of editorial or pictorial content, in any manner, is prohibited.

Table of Contents

Disclaimer	2
Table of Contents	3
Introduction	4
Warranty	5
Serial Number Identification.....	6
General Safety.....	7
Pre-Service Guidelines & Settings.....	10
Greasing & Lubrication	12
Operation.....	14
Scales Display & Power Supply.....	17
Scales Operation	19
Hydraulic Requirements	21
Hydraulic Hose Layout.....	22
Parts Section	28
Notes	65

Introduction

Thank you for purchasing a Giltrap product. *Giltrap Engineering Ltd* has enjoyed a long-standing success with their machinery. We would like you to enjoy the benefits of owning a Giltrap too. By following the guidelines laid out in this book, you will ensure trouble free, low maintenance operating for years.

Giltrap Engineering Ltd is a progressive company which continually strives to satisfy your needs, so we welcome any feedback which you can provide to help us improve our products and services and to ensure that they perform to your expectations. Any constructive comments about this operator's manual are also welcome.

Your machine has been designed to perform its task efficiently and with a minimum of maintenance. This handbook provides safety guidelines, instructions, maintenance requirements and parts listings. We recommend that you read the entire handbook, before operating the machine as this will enable you to take full advantage of your new machine's considerable potential.

Manual Evaluation

We update our operating manuals regularly. Your suggestions for improvement help us to create even more user friendly manuals. Send your suggestions by email to admin@giltrapag.co.nz.

Delivery and Warranty

Before you begin to use your machine, please check it to make sure there is no delivery damage. If damage is evident, contact the dealer who supplied the machine so that they can make the appropriate claims.

If you have any other queries, please contact your dealer or *Giltrap Engineering Ltd* (0800 80 GILTRAP).

All Giltrap products are covered by a 24-month warranty on parts and labour, subject to normal use.

Please fill in the details below for future reference.

Model:

Serial No:

Delivery Date:

Dealer:

Warranty

The Goods specified in the Price List as designed and supplied by Giltrap Engineering Ltd are warranted against faulty workmanship and defective materials for a period of 24 months from the date of purchase. In addition to the primary 24 month warranty for Giltrap products, there is a further 12 month structural warranty for the goods, against faulty workmanship and/or defective materials for structural items only. The structural warranty does not apply to electronics or component parts.

Such warranty is subject to the following conditions:

1. This warranty covers the repair or replacement of parts or machinery sold by the manufacturer and damaged as a result of the faulty workmanship or materials in such parts or machinery. It does not extend to any other loss or damage including consequential loss or damage or loss to other property or persons.
2. Without limiting the generality of paragraph 1 above, this warranty does not cover the following:
 - (a) Travel expenses.
 - (b) Damaged caused by accident, misuse or abuse.
 - (c) Damage to any goods which have been altered or modified by someone other than the manufacturer or its authorised agent.
 - (d) Damage or loss to the goods due to their unsuitability for any particular use or for using with any particular tractor except where such use or tractor had been specifically approved by the manufacturer.
 - (e) Damage or loss where the fitting and installation of the goods were not carried out by the manufacturer or its authorised dealer.
3. Procedure for recovery under warranty.
No loss or damage will be covered by this warranty unless the loss or damage is reported immediately to the dealer (who will contact the distributor who will advise whether it is covered by the warranty and undertake the necessary action).

No warranty repair work is to be undertaken prior to an order number being obtained.

This warranty shall be interpreted according to the laws of New Zealand and the parties agree to submit to the jurisdiction of the Courts of New Zealand.

Warranty Claims

If you wish to make a claim under warranty:

- Immediately stop using the machine.
- List details of the machine and damaged item including serial numbers and date of purchase.
- Consult with your Giltrap dealer (supplier) and have him forward your claim and the damaged item to Giltrap Engineering Ltd.

No warranty to be undertaken unless an order number is obtained from the Seller (Giltrap Engineering Ltd) prior to any work being done.

Serial Number Identification

Before ordering any parts, check the serial number and the delivery date of the machine and include this information with all orders.

If the Serial Number Plate is missing, the serial number will be stamped on the front of the drawbar.

	GILTRAP ENGINEERED PERFORMANCE	Tel +64 7 873 4199 www.giltrapg.co.nz 7 Main North Road Otorohanga New Zealand
DRAWBAR VERTICAL RATING (kg):		GROSS LADEN MASS (kg):
SERIAL No:		MODEL No:
<small>This plate is provided in compliance with the NZ Land Transport Heavy Vehicles 2004 rule, section 4.2. It is the operator's responsibility to ensure that this unit is fully compliant with all current legislation when it is used on public roads. Removal of this plate invalidates certificate.</small>		



Serial number stamped
onto chassis here



General Safety

For the safety of others and yourself, please read and follow the precautions in this operator's manual. Pay particular attention to the following safety aspects of operating machinery.

Do not ride on or allow passengers on the machine.



Always use a recognised hitch pin with a safety clip to hook trailed implements on behind the tractor.

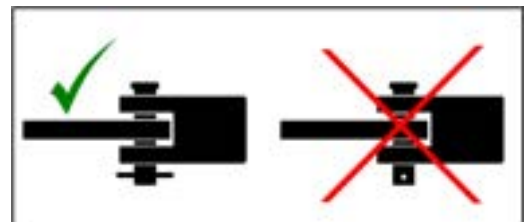

Always ensure when using a quick hitch that the locking tab has come out and is in the locked position before moving.

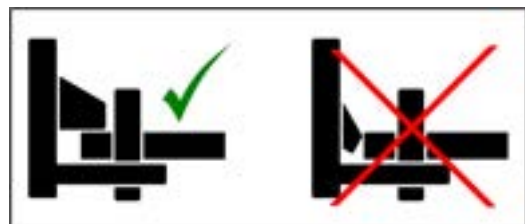

When pulling trailed implements or loads, be sure to use a tractor of greater or equal weight than the combined weight of the load and trailer.

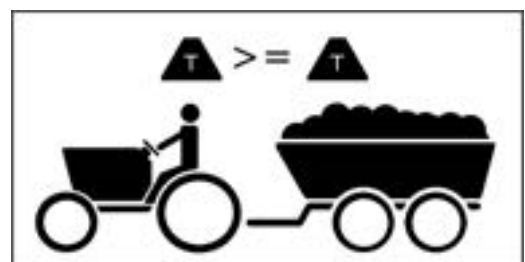

Carry a suitable fire extinguisher.

A fire can ignite under certain conditions, so please take the following precautions:

After running your machine for a short time, check for defective bearings. A faulty bearing can become very hot, eventually discolouring, requiring immediate replacement.

Do not allow combustible material to accumulate inside guards or around rollers and other moving parts.

If your machine becomes blocked, stop immediately and remove the obstruction.

Be careful when operating in hot or dry conditions or on extreme fire risk days.



Never operate your machine without the safety guards in place.



All chains should be properly adjusted and replaced when necessary.

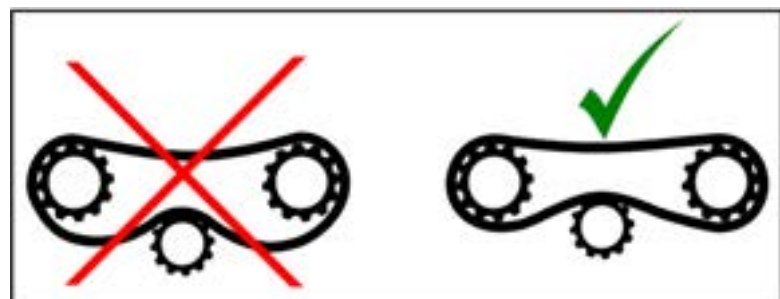

Release all hydraulic pressure from implements before commencing service work. Never look for suspected oil leaks with your hands or body - use a piece of cardboard instead. Any fluid that penetrates the skin will have to be removed immediately by a medical expert. Seek specialist advice on this type of injury.



Never attempt to unblock equipment while it is still operating. Always disengage power take-off, hydraulics and shut down engine before removing materials, checking or servicing. Failure to follow these precautions is likely to result in serious injury.



Wear proper protective clothing. Loose attire can easily be snagged by rotating machinery resulting in serious injury or death.



Pre-Service Guidelines & Settings

Prior to delivering your machine, your dealer should have completed a pre-delivery check.

It is beneficial to check the following points before using the machine for the first time, after the first few loads, then weekly.

CHECK FLOOR CHAIN TENSION. A simple check is to stand in the bin and exert a strong pull at the centre of the floor. There should be approximately **75mm (3")** of vertical movement in this area.

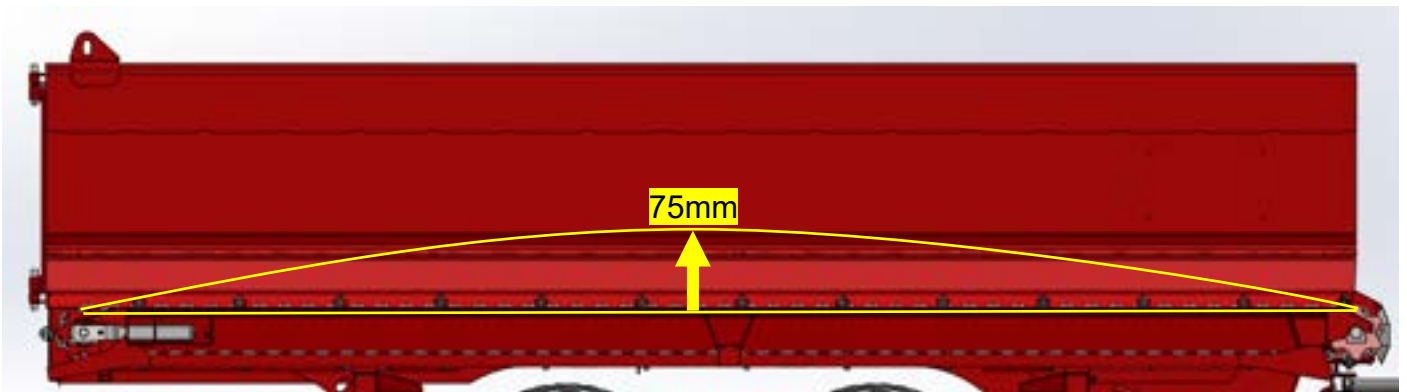

CHECK ELEVATOR CHAIN TENSION. With elevator fully raised, exert a pull at the mid-point of the outside elevator face. If necessary, adjust for approximately **50mm (2")** of movement from rest outwards.

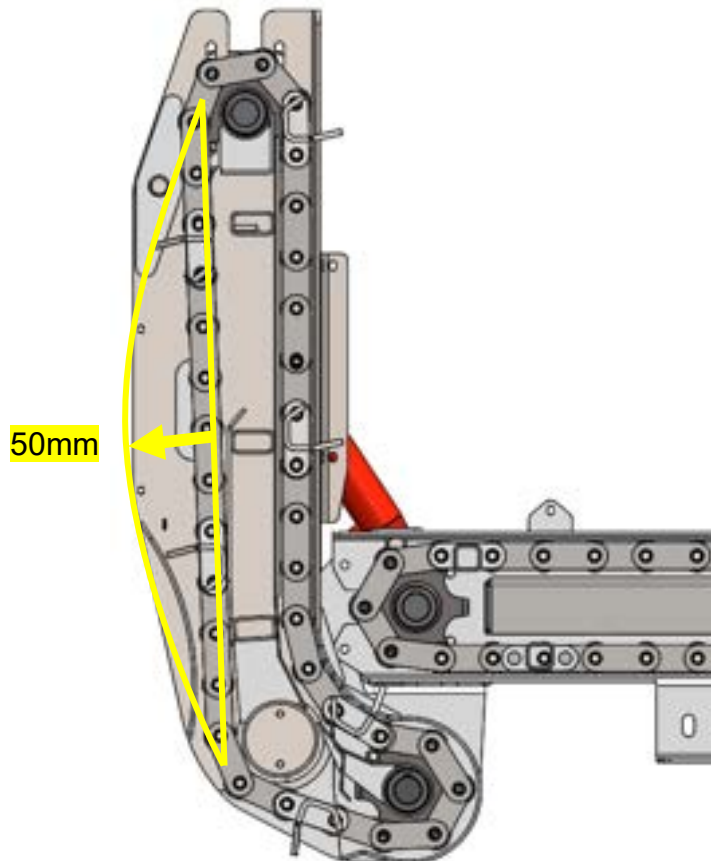

- CHECK ALL WHEEL NUTS ARE SUFFICIENTLY TIGHT.

Wheel Nut Recommended Torque Settings

M18 Stud	200 ft/lbs or 270Nm
M20 Stud	280 ft/lbs or 380Nm
M22 Stud	330 ft/lbs or 450Nm



- CHECK ALL TYRE PRESSURES ARE CORRECT.

Recommended Tyre Pressures

11.5/80-15.3	58psi	4.0 bar
400/60-15.5	50psi	3.5 bar
15.0/70-18	45psi	3.1 bar
400/55-22.5	46psi	3.2 bar
500/45-22.5	35psi	2.4 bar
500/60-22.5	35psi	2.4 bar
560/45R22.5	58psi	4.0 bar
560/60R22.5	58psi	4.0 bar
650/55R26.5	58psi	4.0 bar



- CHECK ALL AXLE MOUNTING BOLTS AND NUTS ARE SUFFICIENTLY TIGHT.

Axle Mounting Bolt Recommended Torque Settings

M16	180 ft/lbs or 245Nm
M20	355 ft/lbs or 480Nm



- THERE ARE SEVERAL GREASE POINTS on all Giltrap feeders. Check the yellow label on the side of your machine to see how many grease points there are. You should fully grease everything before running it for the first time. See page 11-13 for greasing and lubrication details.
- CHECK AND RETIGHTEN WHEEL NUTS AFTER:
 - First use
 - First laden journey
 - The first 50 hours of use and every 50 hours thereafter

Greasing & Lubrication

Greasing & Lubrication Schedule

- Elevator Shaft Bearings** – Grease monthly
- Cross Conveyor Shaft Bearings** – Grease monthly
- Elevator Ram Pivots** – Grease monthly
- Floor Driveshaft Deadeyes** – Grease every 10 loads
- Floor Idler Sprockets** – Grease every 10 loads
- Axle Bushes** – Grease every second day
- Wheel Hubs** – Grease every 3 months
- Rear Gate Latch** – Grease every 3 months
- Rear Gate Pins** – Grease monthly
- Tow Eye** – Grease monthly
- Jack Stand** – Grease monthly

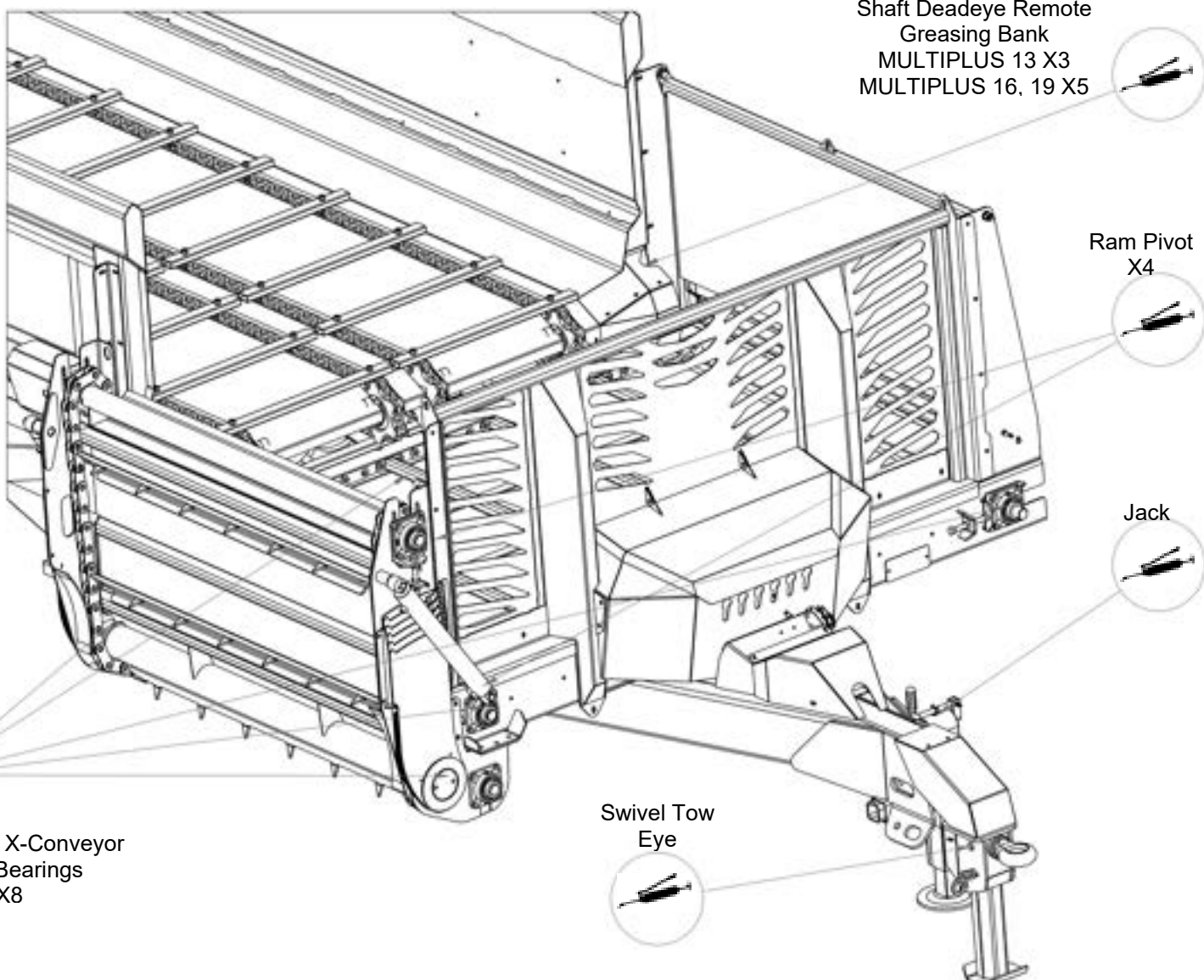

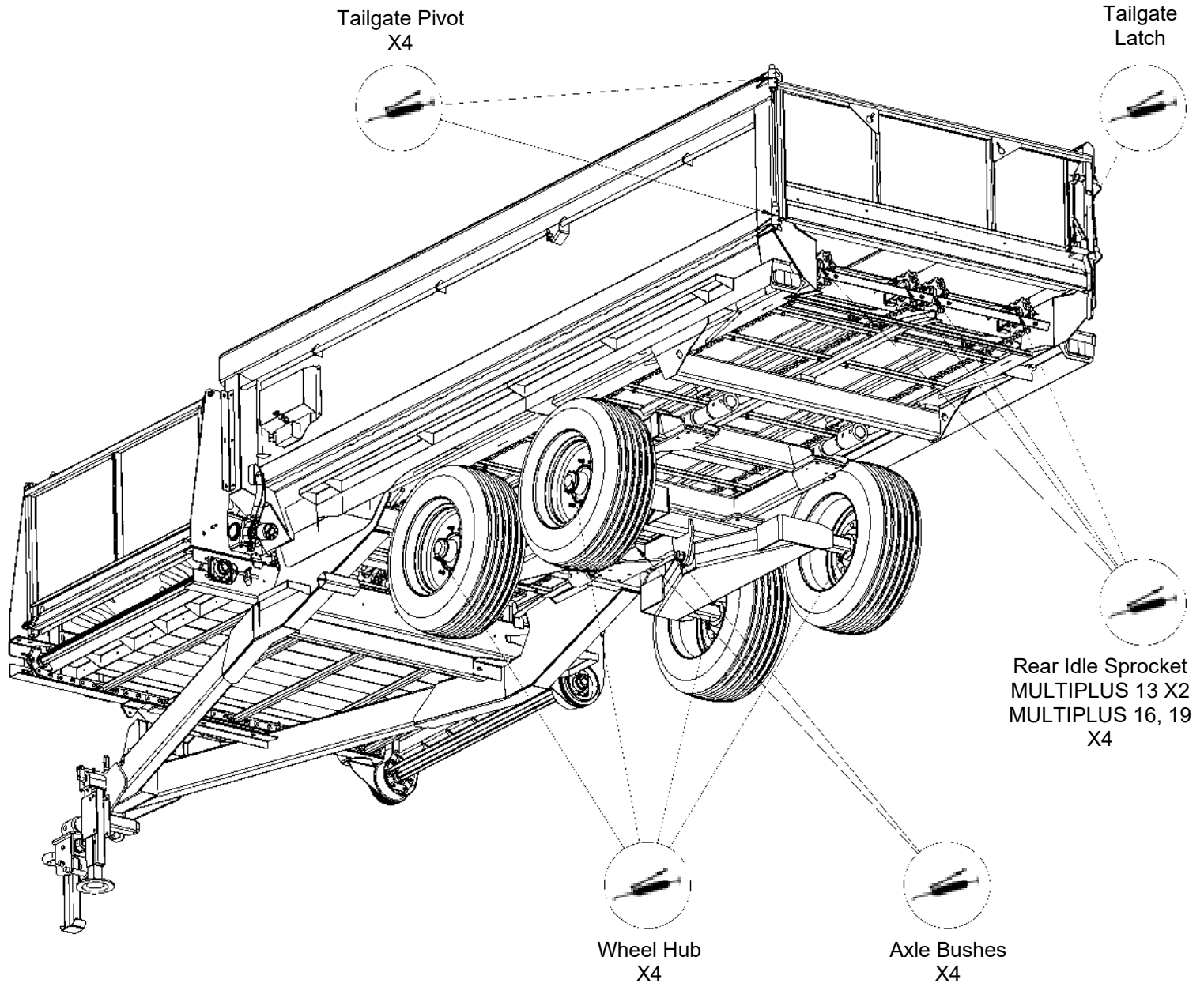

Oil & Grease

Grease Grade Recommended
NLGI 2 oil based

Cross Conveyor Gearbox
Type: Berma RT120-40
Oil: GL-5 80w-90

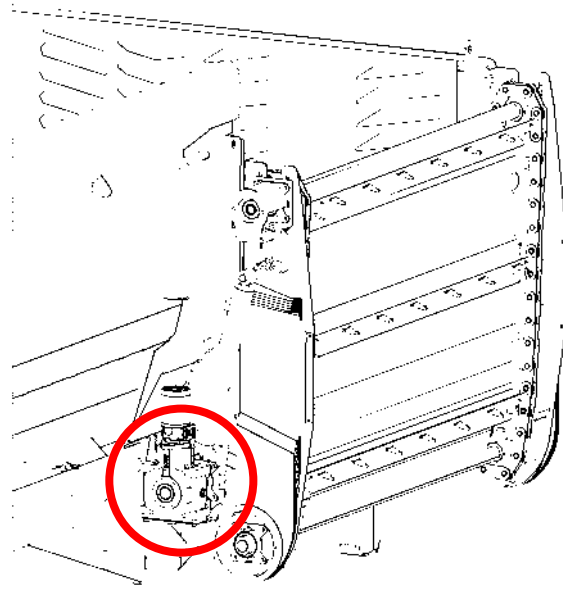

Main Floor Drive Gearbox
Type: Berma RT200-40
Oil: GL-5 80w-90

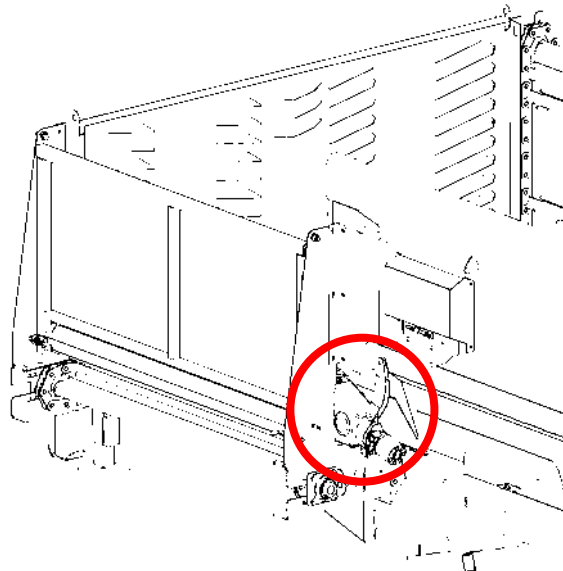

Operation

Loading the Feeder

Load the feeder from the rear to the front. When difficult material has to be handled, e.g. long, wet silage, load the material in sections.

Feeding Out

Best feeding out conditions occur when the feeder is freshly loaded. If left loaded overnight, the material can settle into a hard mass that becomes difficult to feed out. The practice of leaving a load in the machine for hours before feeding out will also accelerate the deterioration of the machine because of the acidic nature of the material.

Standard Control

Standard machines will require three hydraulic remotes - one for each of the main functions. The main floor conveyor, the cross conveyor / elevator, and the elevator position.

When pressure is supplied to the standard valve block (HCV1918A-1), the elevator will run continuously and the cross conveyor will move as required to keep the feed against the elevator. The relief on the valve block can be adjusted via the knob on the left of the machine. Winding the adjuster clockwise increases relief pressure which will increase the feed rate.

The main floor is manual and requires the operator to control the movement of feed from the bin onto the cross conveyor. If required, the main floor can be reversed.

The elevator position can be adjusted to feed into troughs or over/under fences.

The standard side gate on the left of the machine can be unlatched and can be used to feed out.

Diverter Valve Control Option

Machines fitted with a diverter valve will require two hydraulic remotes. One will supply the diverter valve and the other will control the standard valve block. The diverter valve can be switched via the in-cab control to supply the elevator ram circuit or the main floor conveyor motor. The other remote will control the cross conveyor and elevator (HCV1918A-1) as per standard spec above.

The diverter valve is controlled by a coil which is powered on or off to give the two selectable positions. When the coil is switched off, the valve is in position 1 which diverts flow to the main floor motor. When the control is switched on the coil moves the valve into position 2, diverting flow to the elevator ram circuit.

It is recommended that the diverter valve switch be connected to an ignition switched power supply so that if the controller is left set to the position where the coil is switched on and the tractor is turned off, the battery is not drained.

Joystick Control Option

Machines fitted with joystick control will require one hydraulic remote. This supplies a valve block which is controlled by the in-cab joystick and switch. The joystick controls the cross conveyor feed (Joystick left and right) and the main floor feed (Joystick up and down). The feed rate can still be adjusted as standard, using the adjustment knob on the left side of the machine. The momentary switch controls the elevator position.

The joystick control valve block is controlled by 6 coils. The coil plugs on the valve block, numbered 1-6, are connected as show below:

COIL 6	COIL 5	COIL 4	COIL 3	COIL 2	COIL 1
HOSE A1	HOSE B1	HOSE A2	HOSE B2	HOSE A3	HOSE B3
Elevator Up	Elevator Down	Main Floor Forward	Main Floor Reverse	CC Right	CC Left

Scales Display & Power Supply

The remote display is designed to be mounted in the tractor cab and be easily accessible to the driver. It contains a radio frequency (RF) communication device to communicate with the scale system. It will require shielding from the weather elements of sun and rain etc.

The remote display requires 12-24 volts DC to operate. It will typically only draw 0.2A. The power supply must originate from the tractor battery as part of the installation loom (supplied with the machine).

The scales system is powered from the tractor while operating. When disconnected from the tractor, it draws power from its own sealed lead acid battery.

The tractor requires an installation loom (supplied) which provides a switched and fused positive and negative supply from the tractor battery to the rear 7-pin socket. The tractor battery is the best power supply point as it provides the most stable and “quiet” power source. Do not use any other power source.

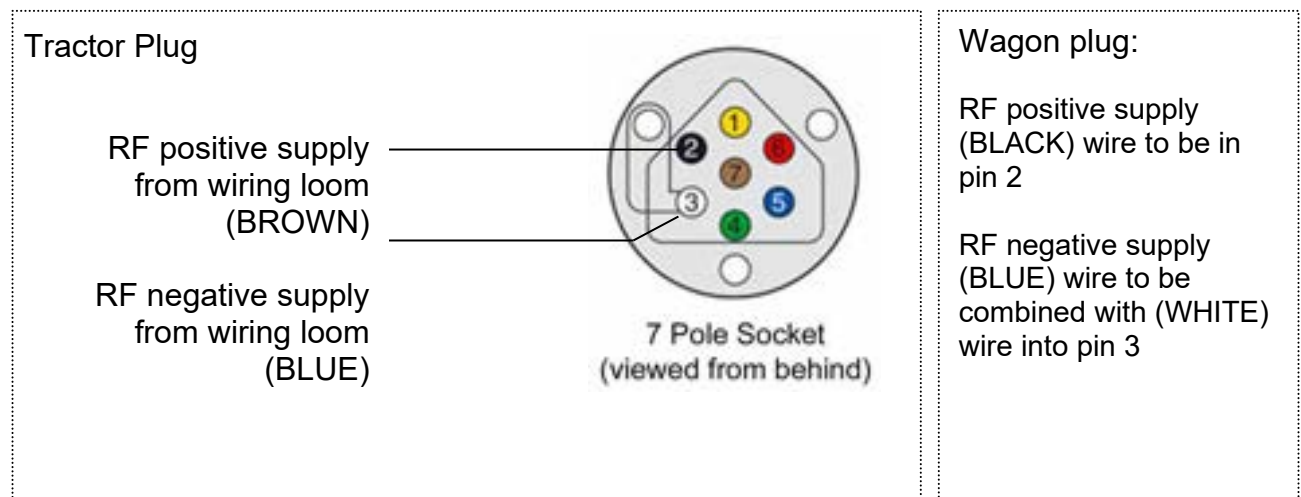

There are three CPC connectors on the Control module. If a connector is not used, place the terminal cap over it.

Remote Display Layout

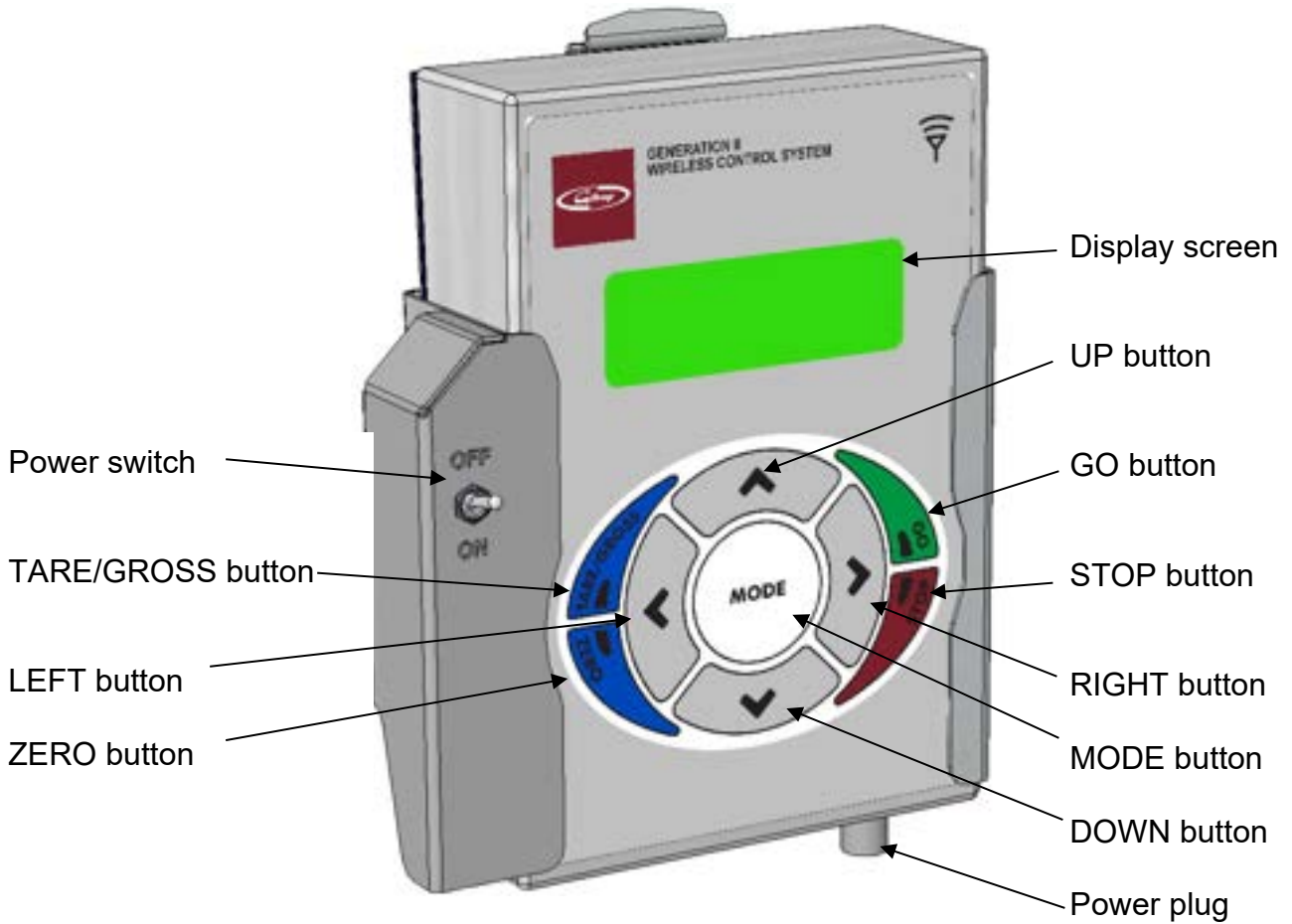

Controller Layout

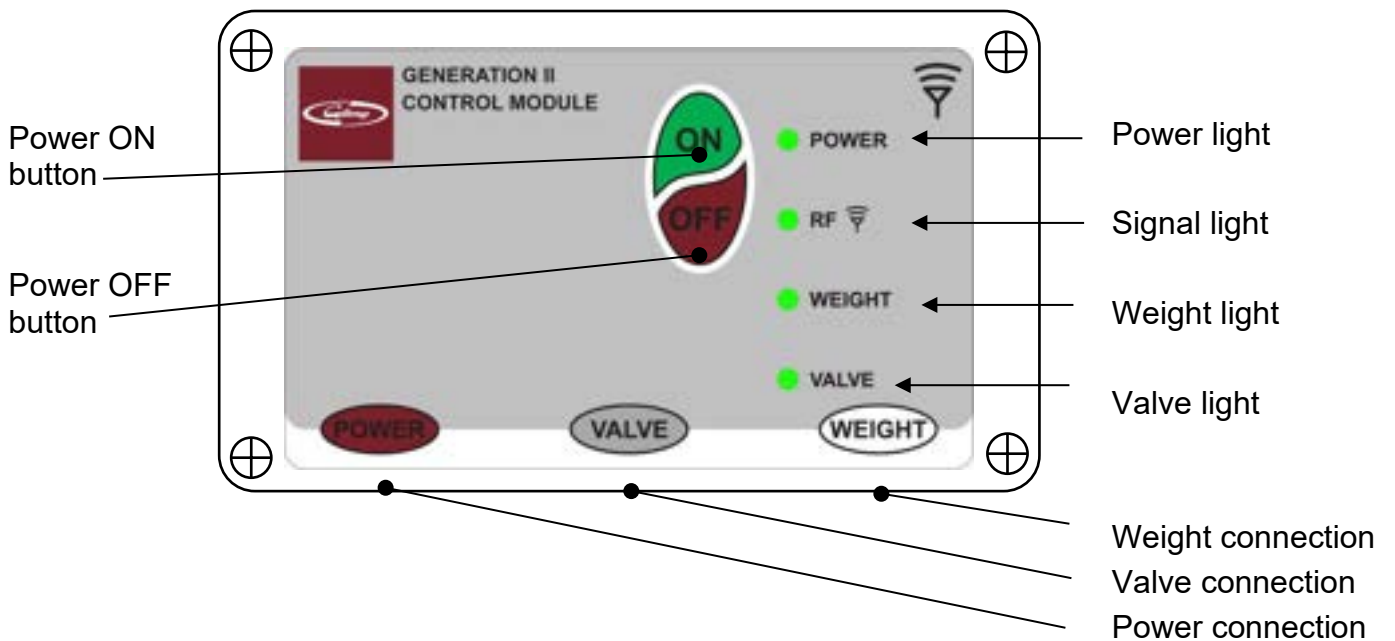

Scales Operation

Power for the system is controlled by the switch adjacent to the Remote Display.

1. Turn the switch on to provide power to the Remote Display and the wagon.
2. If the wagon is disconnected, press and hold the ON button on the Controller for one second. The Controller is now operating on its own battery.
3. Begin loading the wagon.
4. Once completed loading, connect the wagon to the tractor and connect the 7-pin plug.
5. Once ready to feed, select the appropriate mode and press GO button. You are now ready to proceed.

Note: The Controller power light will illuminate when the ON button is pressed or the wagon is plugged into the tractor. To turn off, the wagon must be un-plugged before pressing the OFF button.

Start-up Screen

When the Remote Display is powered up, the start-up screen is displayed for 3 seconds as below. After this the screen will change to the operating screen.

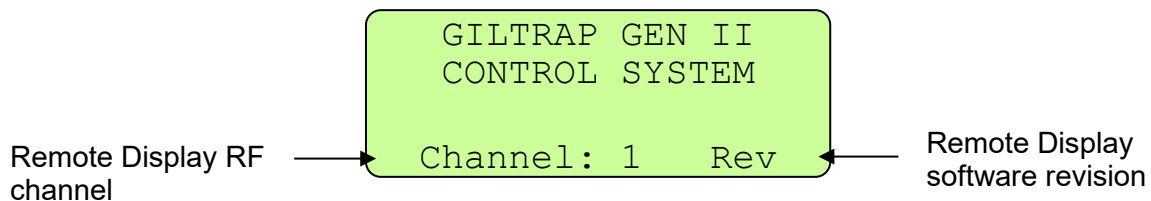

If the wagon is not connected i.e. not getting power from the tractor, the controller will not start. The screen below will display until communication has begun by plugging in the wagon or pressing and holding the GO button on the controller for 1 or more seconds. After establishing communication, it will proceed directly to the next screen.

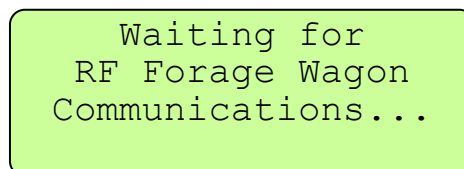

Once communication has begun between the devices, a screen similar to the one below will show.

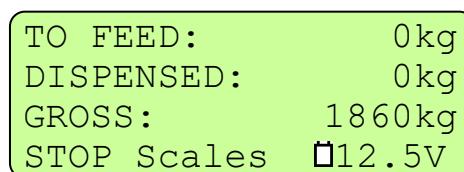

In Scales mode, the screen will only display weight figures.

The operator can enter a target weight to feed when a beeper will sound.

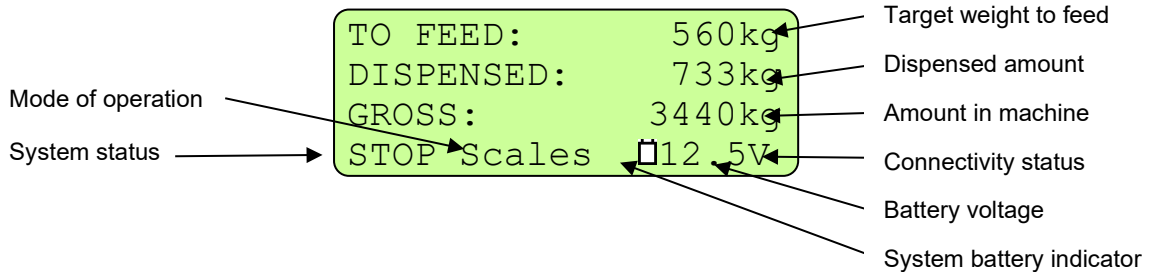

Features:

- The top line shows the weight to feed out before a beeper sounds.
- The second line shows the weight dispensed since GO was pressed.
- The third line shows the tare or gross weight in the machine.
- The bottom line of the screen shows the mode of operation (Scales), the battery voltage (highest voltage available to the unit. When disconnected from the tractor, this will be the internal battery voltage), and connectivity status.

Operating Notes:

The operator can adjust the weight to be dispensed by adjusting the 'TO FEED' figure. This is done by pressing UP or DOWN on the keypad when the 'TO FEED' figure is underlined. Use the RIGHT or LEFT button to move the underline cursor.

The operator can select between gross and tare weight to be displayed by pressing TARE/GROSS on the keypad.

The operator can zero only the dispensed weight by pressing GO on the keypad.

To allow the dispensed weight to accumulate and the target feed weight to work, the operator must press GO before commencing feeding.

The operator can zero the gross weight and dispensed weight by pressing ZERO on the keypad.

Hydraulic Requirements

For optimal machine performance the tractor used should be checked to provide an oil flow rate of between 30 and 60 litres per minute at full working pressure – Usually between 2500psi (170 Bar) and 2800psi (190 Bar). If these conditions are not satisfied, the feeder will perform poorly or not at all.

Technical Notes:

- Machines that develop or operate with a jerking or shuddering action can be rectified by fitting a non-standard inline valve (SCCB 154Z P8) with relevant fittings between the port marked “ELEV PRES: and the elevator motor. This preloads the hydraulic circuit and smooths the operation.

Quick Valve Orifice Diagnosis

If orifice (5) is blocked then the cross conveyor will not drive load onto elevator when loaded.

If orifice (6) is blocked then the floor will not slow down when the DPBB (3) is adjusted out and floor will likely overload and stall the elevator.

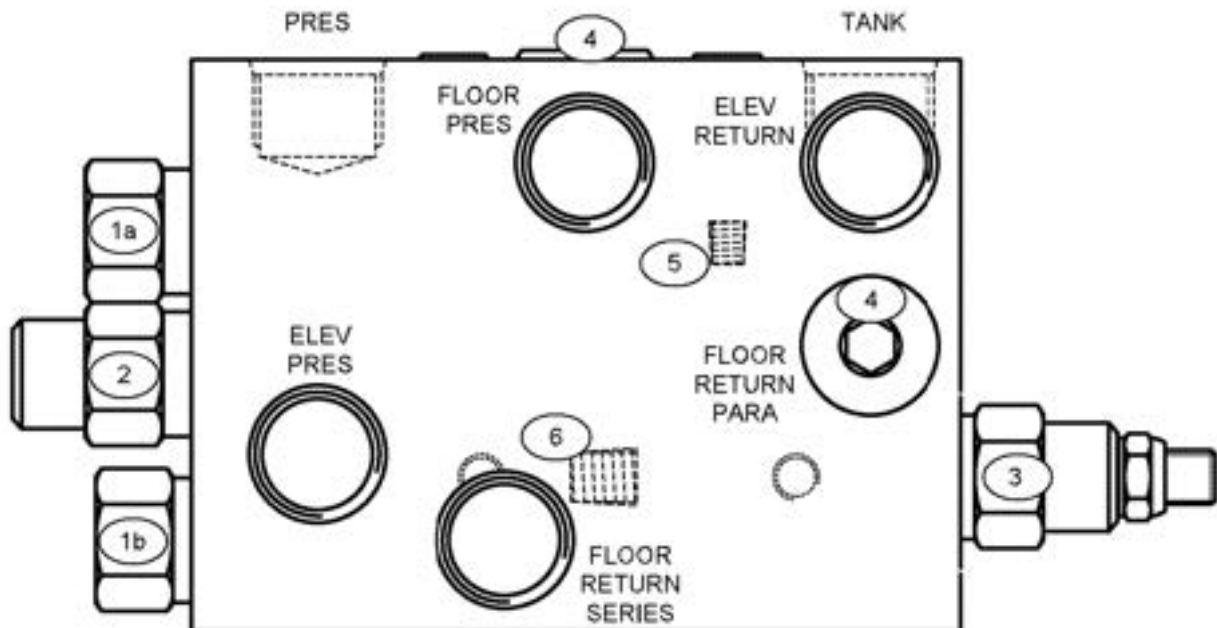

Hydraulic Hose Layout

Standard

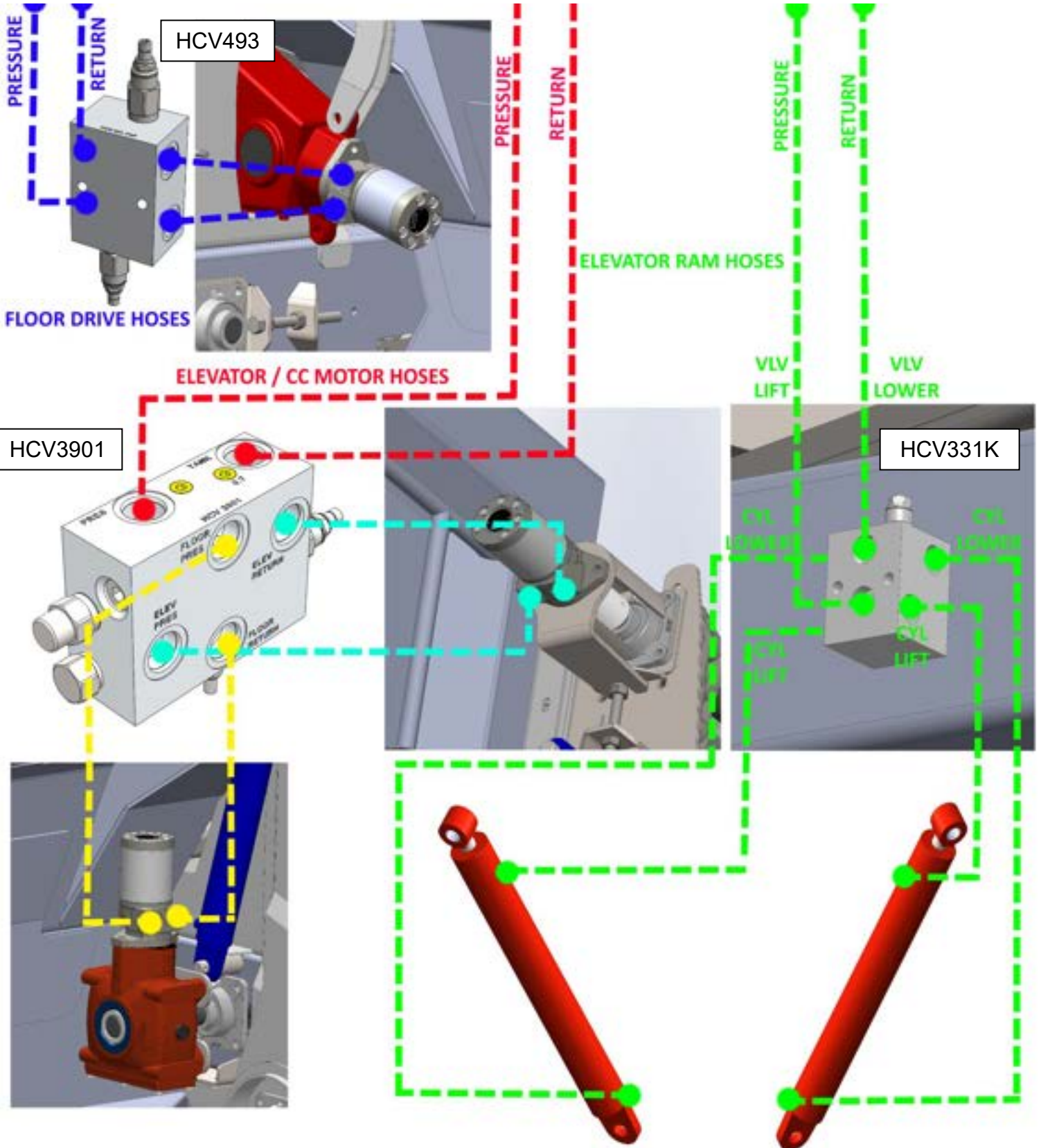

Option 2 – Diverter Valve

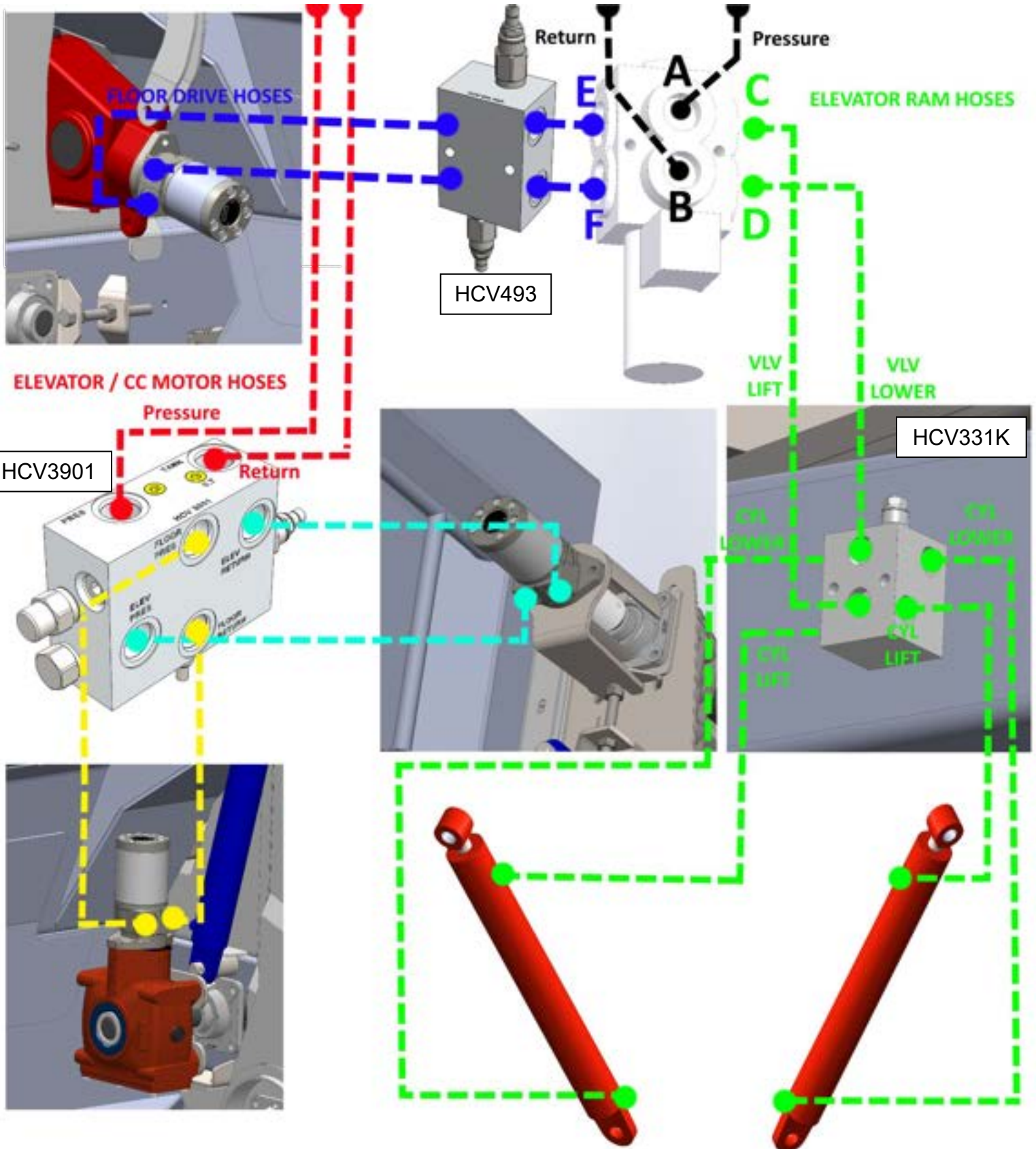

Option 3 – Joystick Control

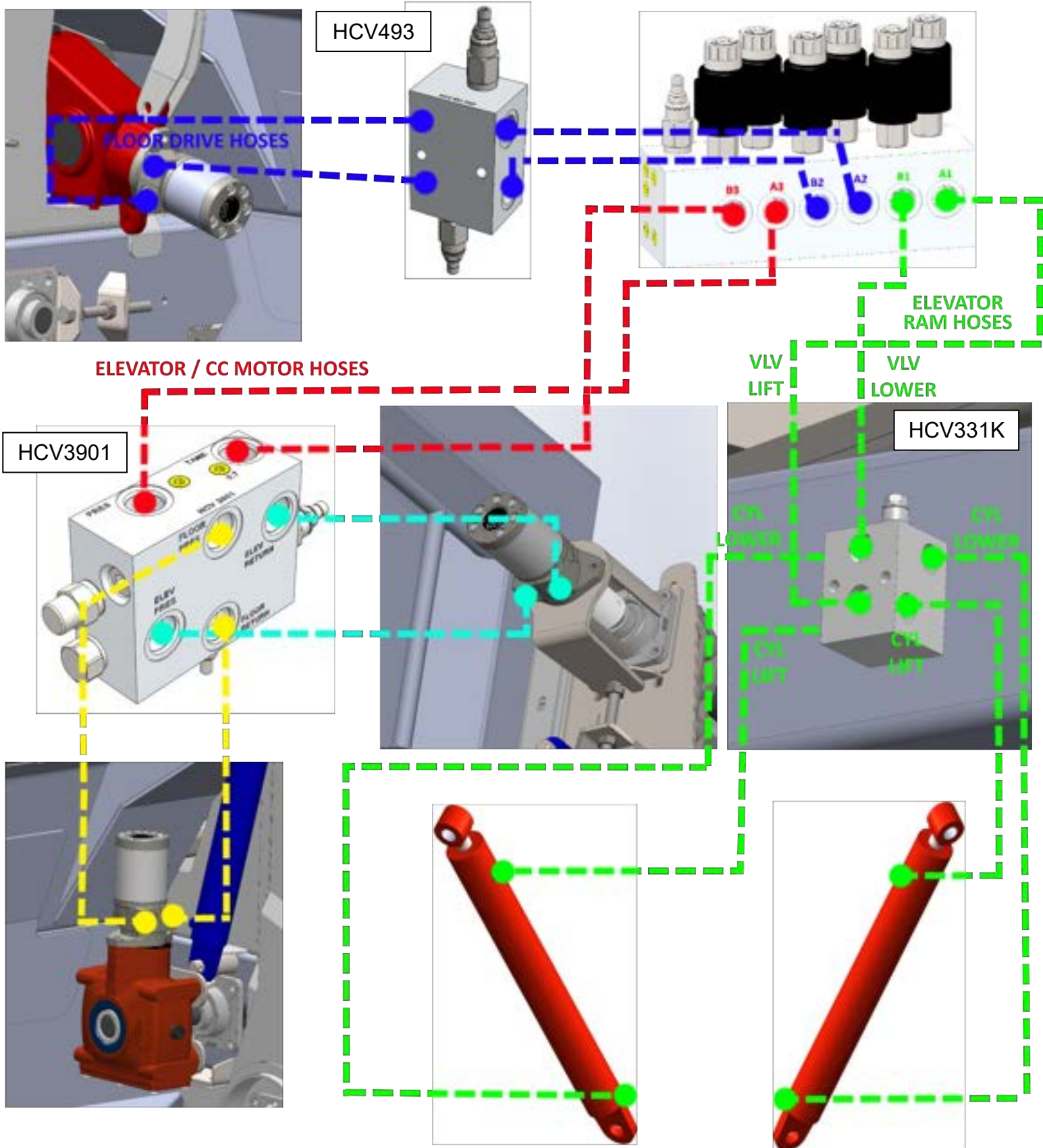

Maintenance



The location of the floor chain tensioners is at the rear of the machine as shown in Fig.1. To tension, loosen lock nut and wind adjuster bolt in to extend idler further rearward. Check tension of all chains as per the pre-service guidelines on page 10 then lock adjusters in place with lock nut.

Figure 1

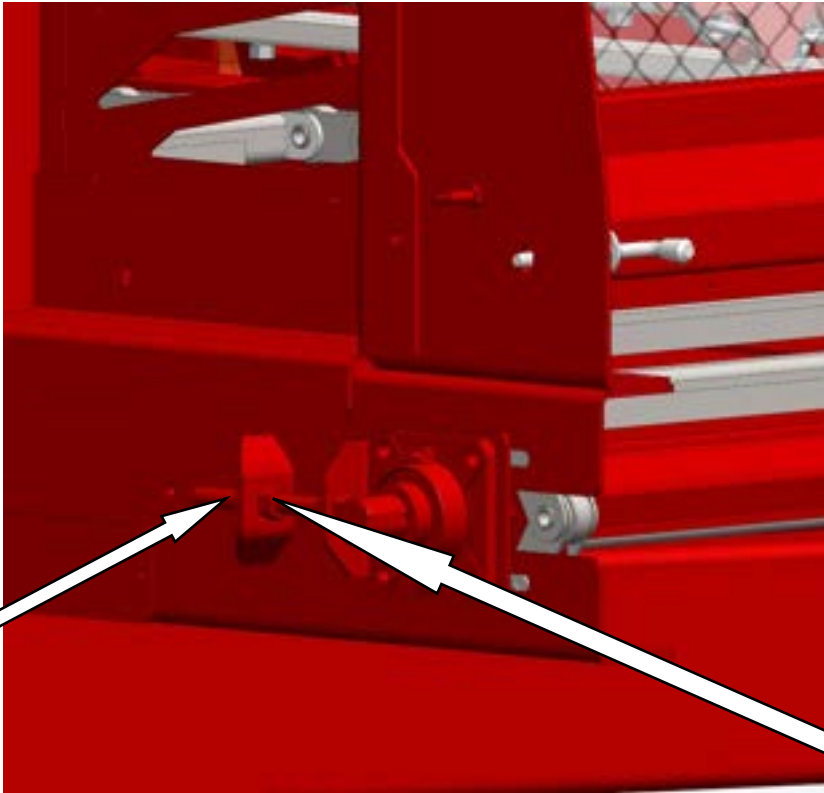

To tension cross conveyor chains, loosen bolts fastening the two bearing flanges on the left side of the machine. Evenly tension shaft adjusters on both sides and tighten nuts on both sides of adjuster tab to fix in place.

Figure 2

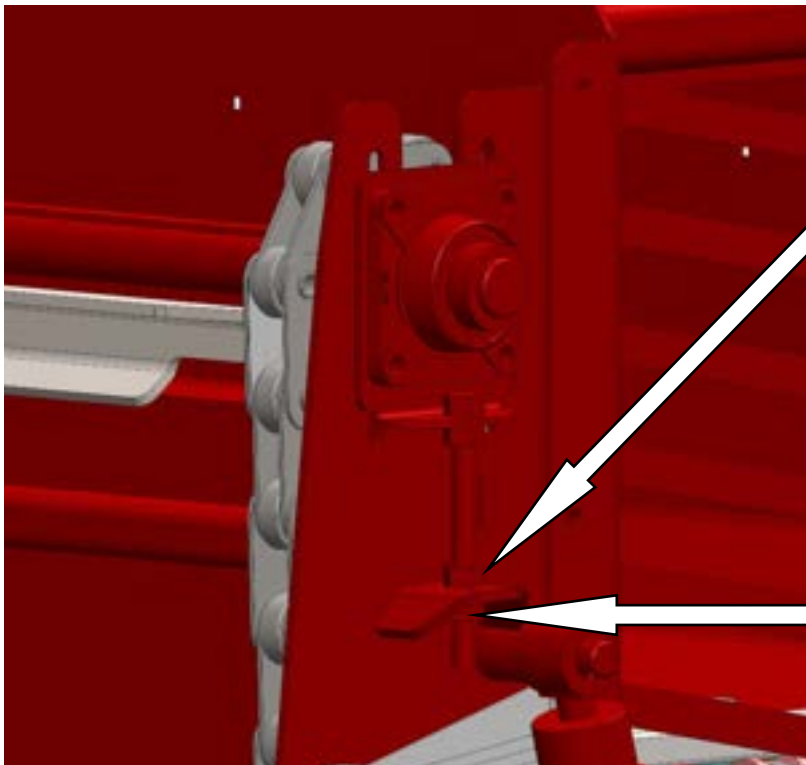

To tension elevator chains, loosen bolts fastening the two bearing flanges on the end of the elevator. Evenly tension shaft adjusters on both sides and tighten nuts on both sides of adjuster tab to fix in place. **ONLY TENSION WHEN ELEVATOR IS IN FULLY RAISED POSITION**

Figure 3

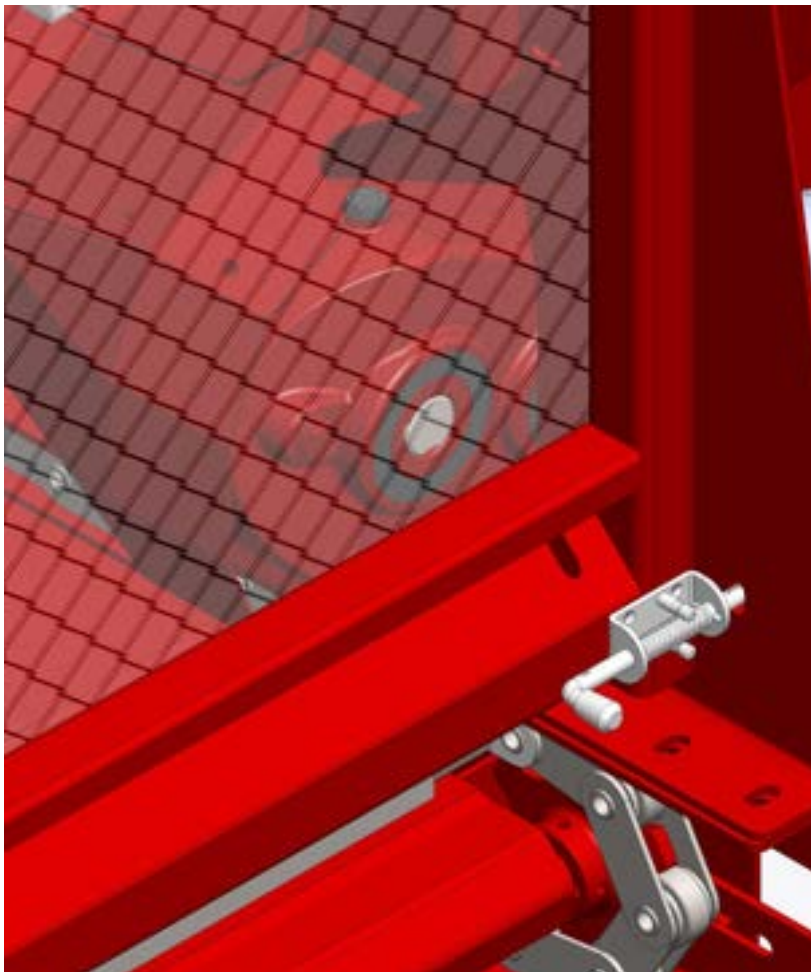

The main floor uses a motor and gearbox reduction drive located on the left side of the machine. Check oil levels through the sight glass on the side of the gearbox. Add oil as required through fill point on top.

Remote Greasing point for the driveshaft deadeyes located on front end of the bin on the left side – above step

Figure 4

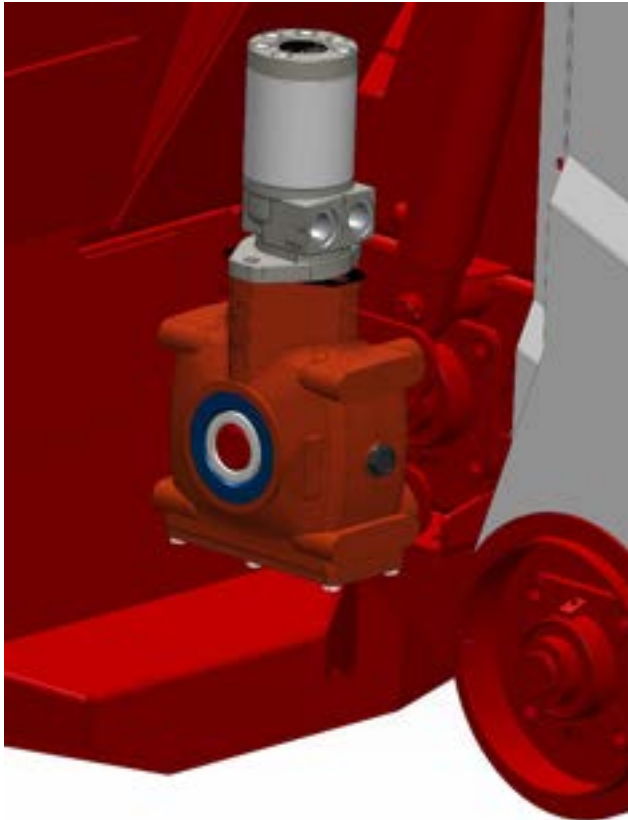

Figure 5

The cross conveyor uses a motor and gearbox reduction drive located on the right side of the machine. Check oil levels through the sight glass on the gearbox. Add oil as required through fill point on side.



Figure 6

The back gate is protected by a crash lock mechanism that can be opened manually by pulling on the handle shown; otherwise the gate will open under pressure applied by a reversing load on the floor.

The load setting of the crash lock system can be adjusted by removing the end cap fitting which encloses a compression spring that applies pressure to the ball bearing that locks the handle in place. The adjustment is made via a threaded adjuster within the spring assembly. Replace the end cap after adjusting.

Parts Section



Parts Section	28
TRANSFERS & DECALS	30
ELECTRONICS & CONTROL SYSTEM.....	31
<i>Scales</i>	31
<i>Diverter Valve Control – Up to May 2022</i>	32
<i>Diverter Valve Control – May 2022 on</i>	33
<i>Joystick Control</i>	34
HYDRAULIC CONTROL VALVES	35
<i>HCV 311K P6P CBCA</i>	35
<i>HCV 1918A-1</i>	36
<i>HCV 3901</i>	37
<i>HCV 3744</i>	38
<i>HCV 166H P8P RDDA</i>	39
<i>HCV 493 P8P</i>	40
<i>HCV 311H P8P CKCD</i>	41
.....	41
<i>Walvoil DFE052/6</i>	42
TOW EYE ASSEMBLY (MULTIPLUS 13)	43
TOW EYE ASSEMBLY (MULTIPLUS 16, 19)	44
JACK ASSEMBLY	45
FEED UNIT ASSEMBLY	46
ELEVATOR ASSEMBLY	47
CROSS CONVEYOR EXTENSION ASSEMBLY	49
REAR GATE ASSEMBLY.....	51
SIDE GATE ASSEMBLY SHREDDER ASSEMBLY – OPTIONAL.....	51
PANELS, GUARDS & COVERS	53
FLOOR TRANSMISSION – FOUR CHAIN MODELS (MULTIPLUS 16, 19)	56
AXLE / SUBFRAME ASSEMBLY – MULTIPLUS 13	56



AXLE / SUBFRAME ASSEMBLY – MULTIPLUS 16	57
AXLE / SUBFRAME ASSEMBLY – MULTIPLUS 19	59
HUB ASSEMBLY – ADR	59
GEARBOX	62
<i>Berma RT120</i>	62
<i>Berma RT200</i>	63
BRAKE HOSE & CYLINDER CONFIGURATIONS	64
.....	64
Notes	65

Transfers & Decals

ITEM NO.	PART NUMBER	DESCRIPTION	QTY.
1.1	12697	Transfer 'MULTIPLUS 13'	2
1.2	12698	Transfer 'MULTIPLUS 16'	2
1.3	12699	Transfer 'MULTIPLUS 19'	2
4	995-1025	Label 'Caution! Ensure Hydraulic...'	1
5	995-1212	Label 'Warning - Ensure Chains...'	3
6	995-1221	Label 'Stand Well Clear...'	3
7	995-1222	Label 'Do Not Stand In...'	2
8	995-1223	Label 'This Machine Has...'	1
9	995-1228	Label 'Ensure Jack Is In...'	1
10	995-1229	Label 'Do Not Operate...'	1
11	995-1230	Label 'Read Operators Manual...'	1
12	995-1240	Label 'DANGER'	1
13	995-1245	Label, Grease Gun	3
14	995-3045	Multiplus 'G' Decal - White	1
15	12754	Label, Warning - Drawbar	1
16	12754	Label, Warning - Chains & Bars	4
17		HARDOX Sticker	2

Electronics & Control System

Scales

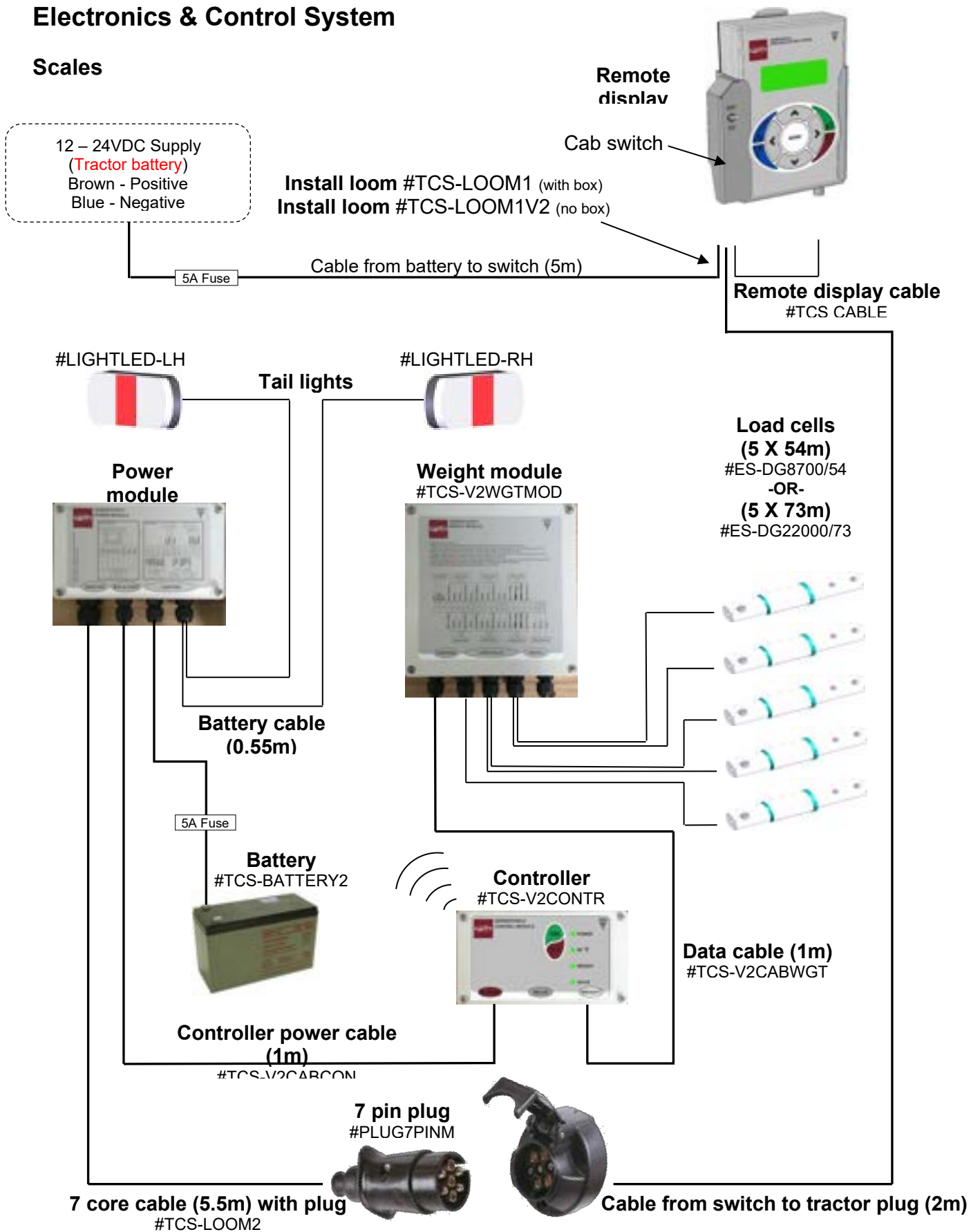

Diverter Valve Control – Up to May 2022

- Note: the red hand switch handle and loom may be replaced with switch box (see next page).



ITEM NO.	PART NUMBER	DESCRIPTION	QTY.
1	HYV12A270026	Walvoil DFE052/6 6 Port Diverter Valve	1
2	GE-SPSL-1	Handle Loom c/w Power Terminals, Socket, and Switch Handle	1
3	GE-SPSL-1A	Implement Loom c/w Loom Plug and DIN Plug	1
4	135-4555	Switch Handle	1

Diverter Valve Control – May 2022 on



ITEM NO.	PART NUMBER	DESCRIPTION	QTY.
1	HYV12A270026	Walvoil DFE052/6 6 Port Diverter Valve	1
2	14263	Switch Box Loom c/w Power Terminals, Socket and Switch box	1
3	GE-SPSL-1A	Implement Loom c/w loom Plug and DIN Plug	1

Joystick Control



ITEM NO.	PART NUMBER	DESCRIPTION	QTY.
1	HYHCV 3744	HCV 3 Bank Remote	1
2	GE-12693	Implement Loom	1
3	GE-SPSL-6	Control Unit Loom	1
4	12691	Circuit Board	1
5	12668	Joystick Box Assembly	1
6	825-2593	Joystick	1
7	12669	Adaptor Plate	1

Hydraulic Control Valves

HCV 311K P6P CBCA

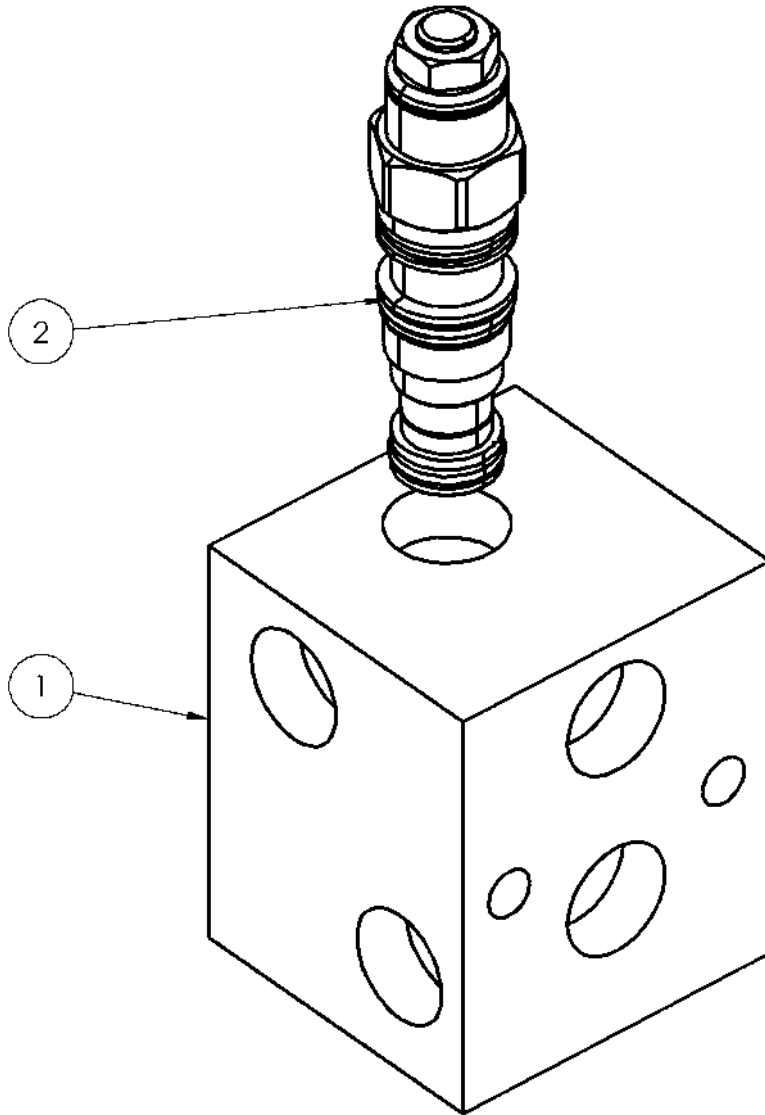

ITEM NO.	PART NUMBER	DESCRIPTION	QTY.	SETTING
1	HYHCV 331K	Valve Block	1	-
2	CBCA-LHN	Counterbalance Valve (3:1)	1	3000psi

HCV 1918A-1

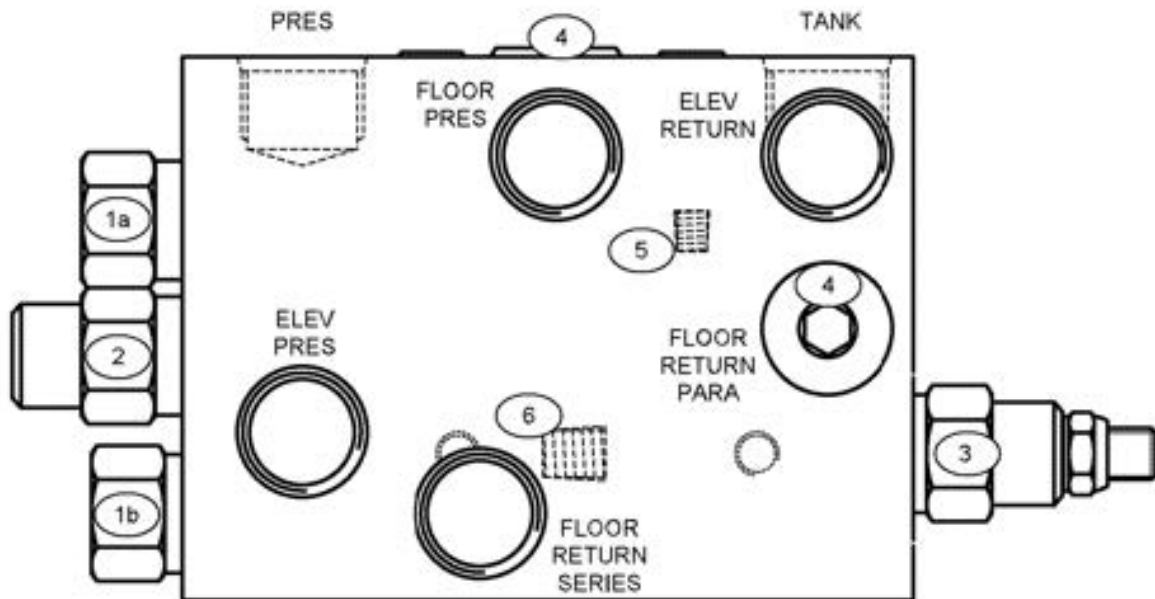

Position	Qty	Part Number	Description	Setting
1 (a & b)	2	CXDA XAN	Check Valve	4 psi
2	1	LHDA XEN	Flow Compensator	75 psi
3	1	DPBB LWN	Unload Sensing Valve	
4	1	7/8" UN Plug	Blank Plug	
5	1	1/16" NPT x 0.8mm	Dampening Orifice	
6	1	1/8" BSPT x 0.8mm	Dampening Orifice	

*HCV1918A-1 superseded by HCV3901

*If machine is fitted with valve HCV1918A-1, HCV311H P8P CKCD will be plumbed into the "ELEV RETURN" & "FLOOR PRES" ports.

HCV 3901

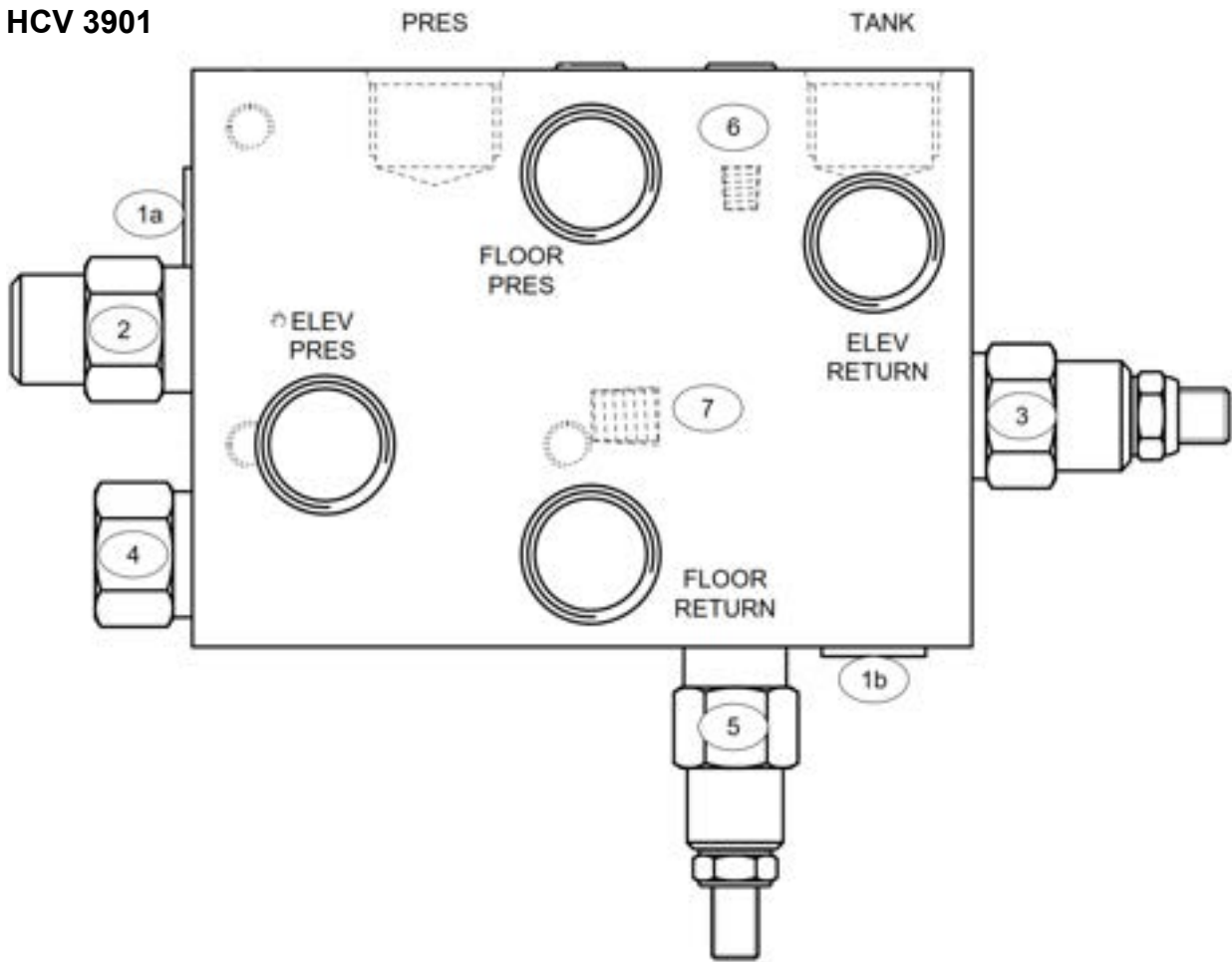

Position	Qty	Part Number	Description	Setting
1 (a & b)	2	CXBG XAN	Check Valve	4 psi
2	1	LHDA XEN	Flow Compensator	75 psi
3	1	DPBB LCN	Unload Sensing Valve	1700 psi
4	1	CXDA XAN	Check Valve	4 psi
5	1	RDBA LAN	Floor Relief Valve	1700 psi
6	1	1/16" NPT x 0.8mm	Dampening Orifice	
7	1	1/8" BSPT x 0.8mm	Dampening Orifice	

HCV 3744

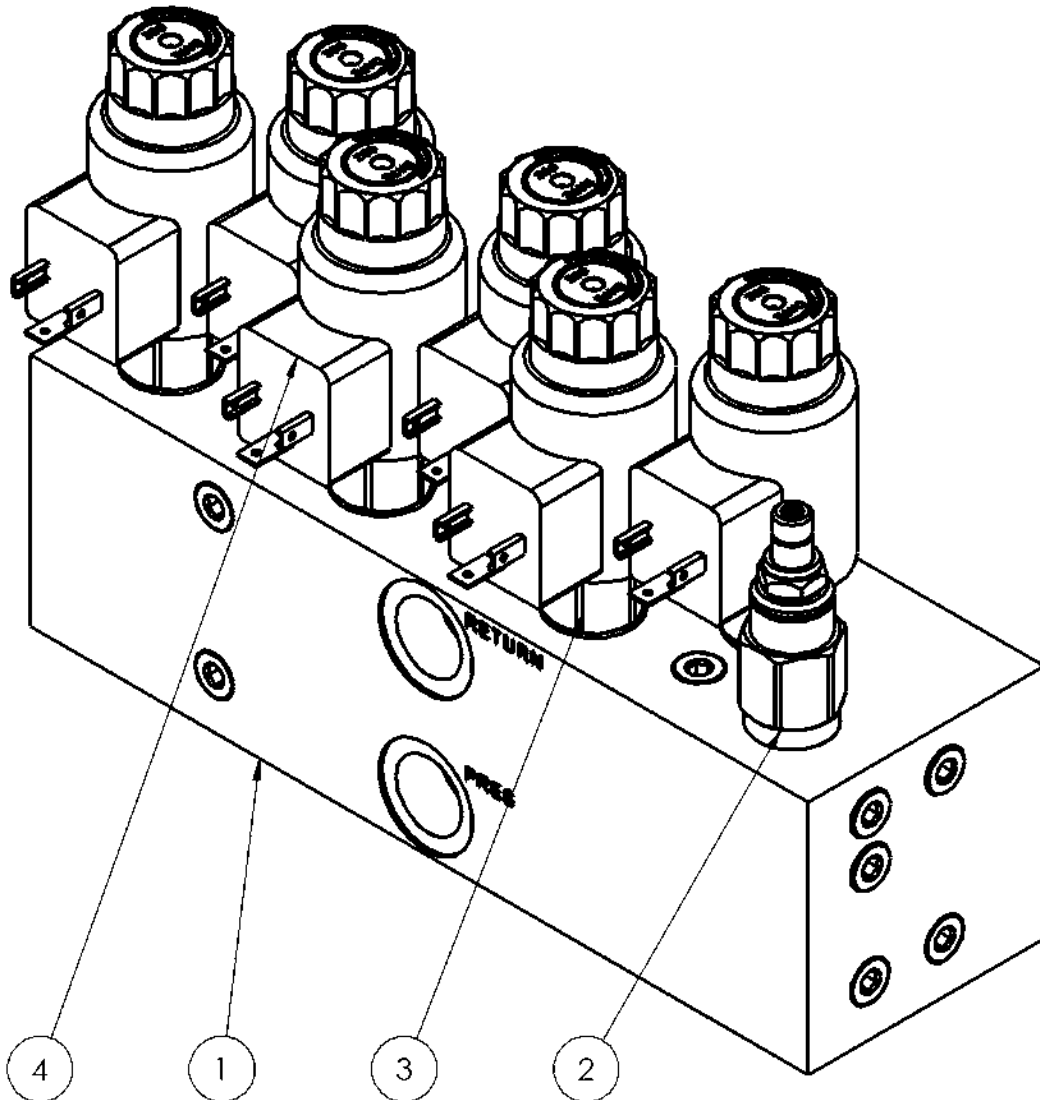

ITEM NO.	PART NUMBER	DESCRIPTION	QTY.	SETTING
1	HYHCV 3744	HCV 3 Bank Remote - Complete	1	-
2	RDDA LWN	Direct Acting Relief	1	3000psi
3	DMDA MNN	3 Port Solenoid Selector Spool	6	-
4	770 212	12V DC DIN Coil	6	-

HCV 166H P8P RDDA

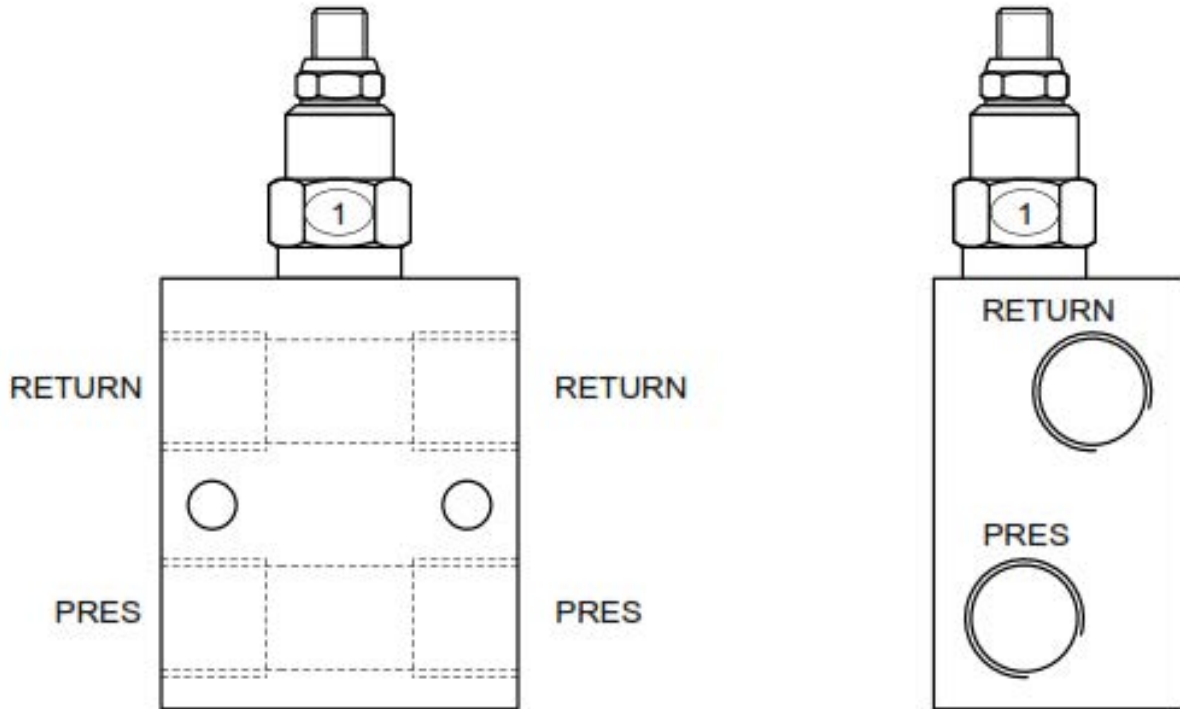

Position	Qty	Supplier Part #	Description	Setting
1	1	RDDA LWN	D.A Relief Valve	

HCV 493 P8P

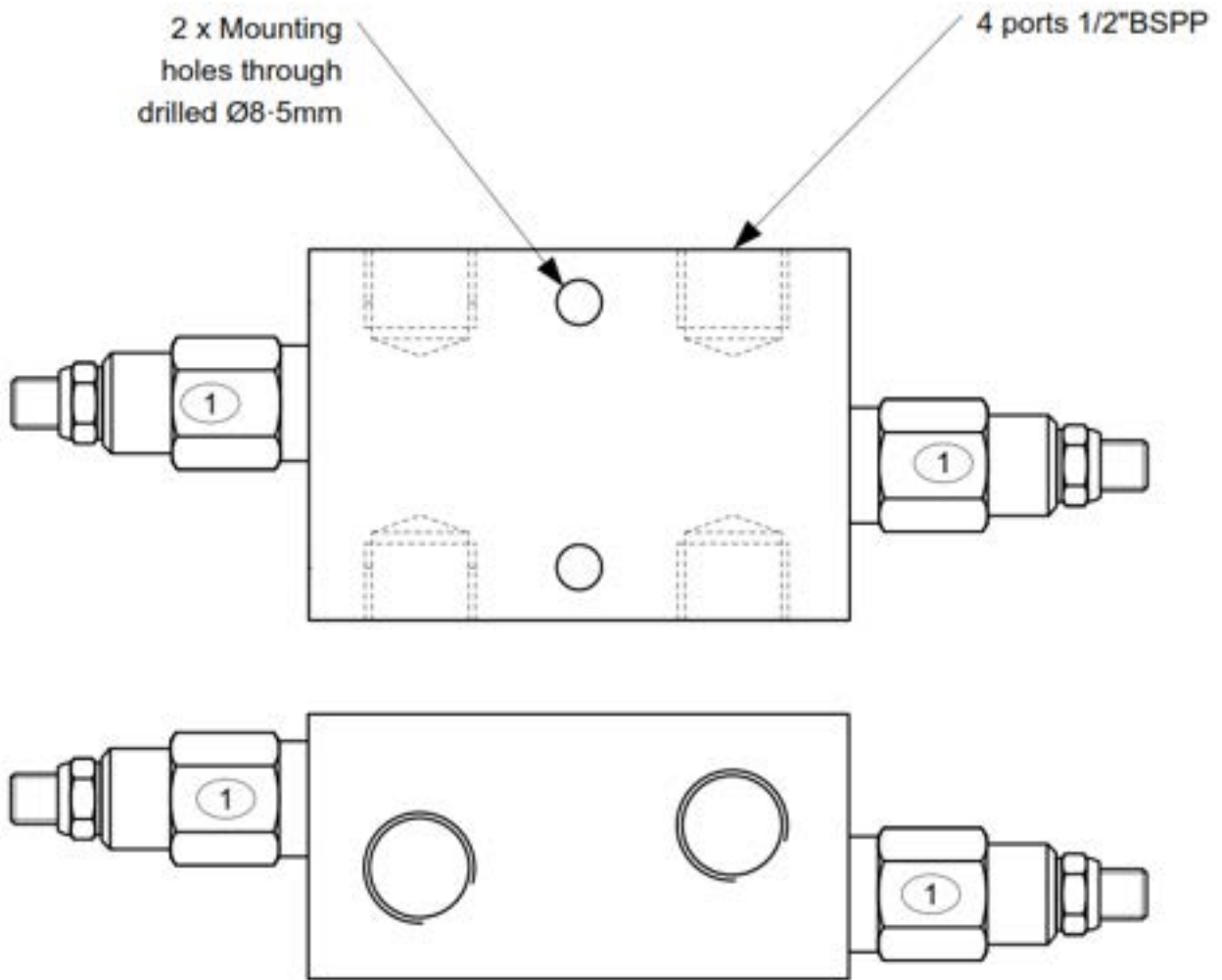

Position	Qty	Supplier Part #	Description	Setting
1	2	RDDA L*N	D.A Relief Valve	1800psi

HCV 311H P8P CKCD

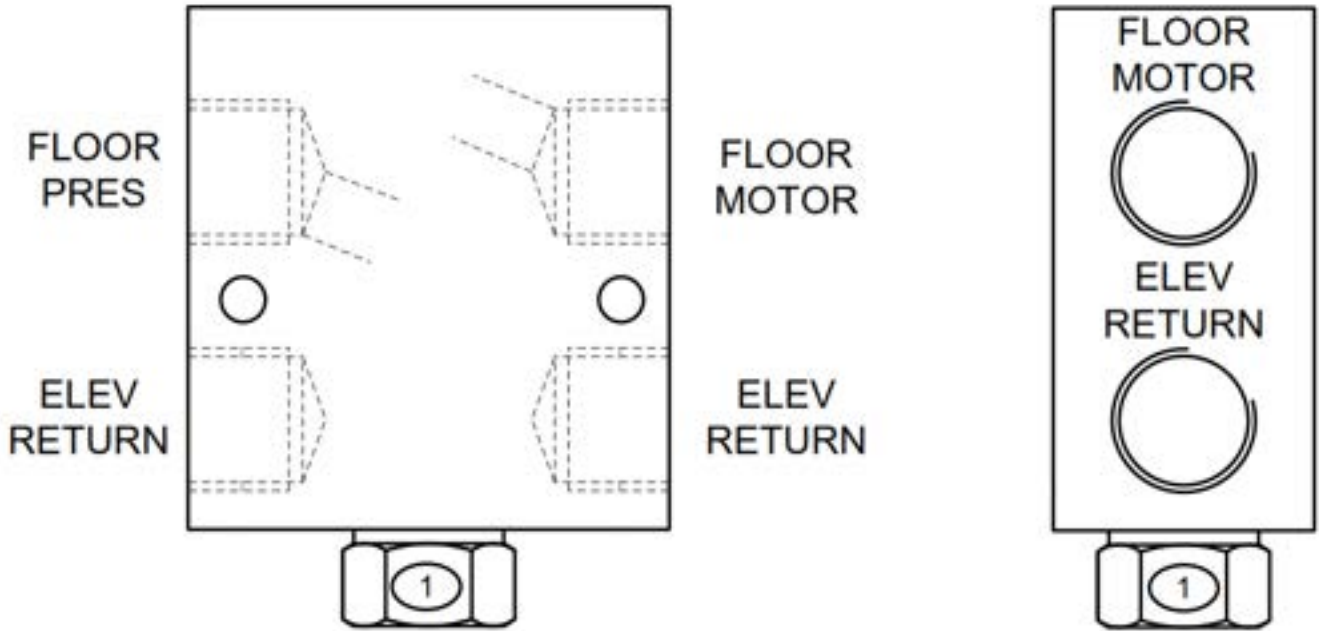

Position	Qty	Supplier Part #	Description	Setting
1	1	CKCD XCN	Pilot To Open Check Valve	

Walvoil DFE052/6

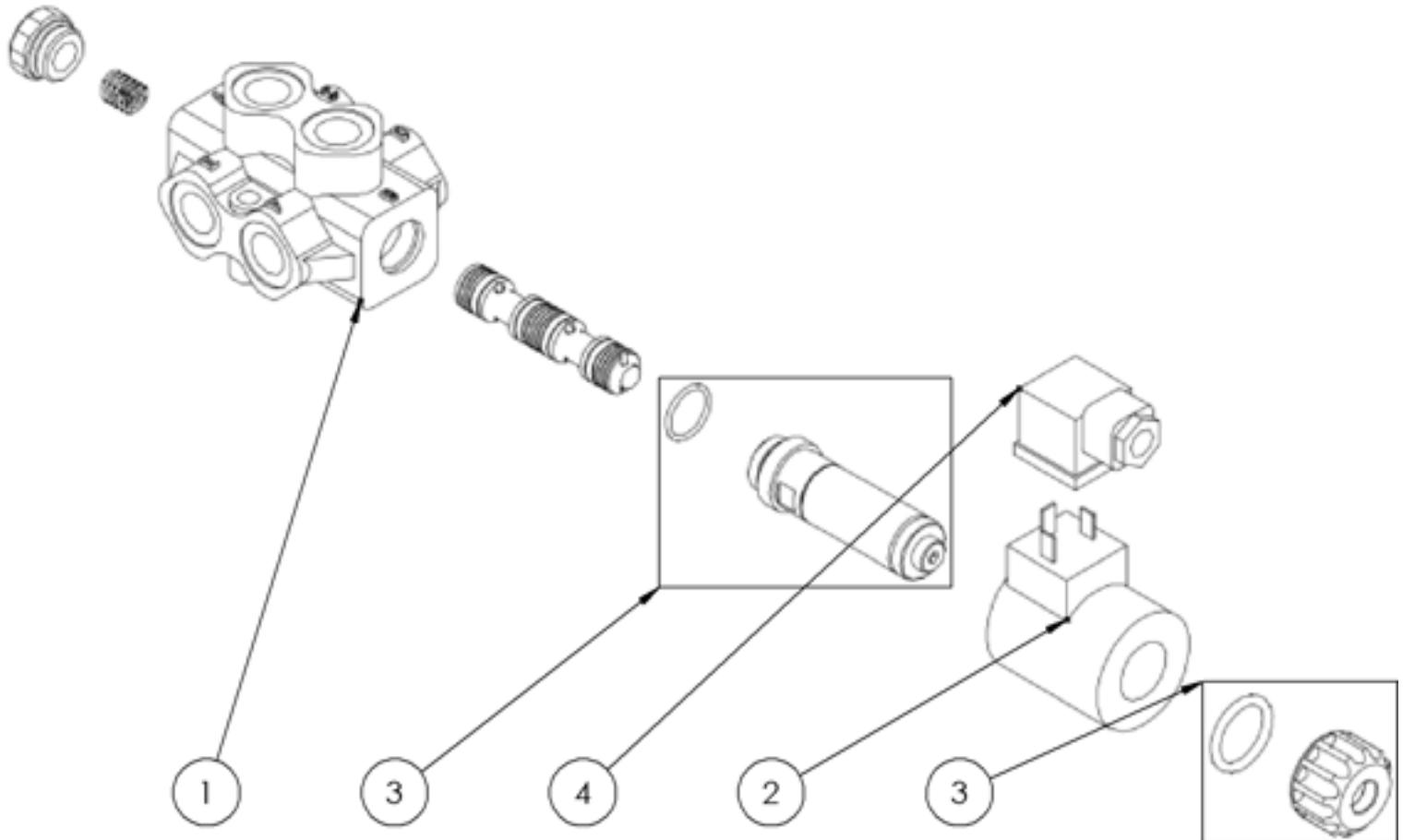

ITEM NO.	PART NUMBER	DESCRIPTION	QTY.
1	HYV12A270026	Valve Block - Complete	1
2	4SOL515012	12V DC DIN Coil	1
3	5SOL515000	Solenoid Assembly	1
4	11695	DIN Coil Plug	1

Tow Eye Assembly (MULTIPLUS 13)

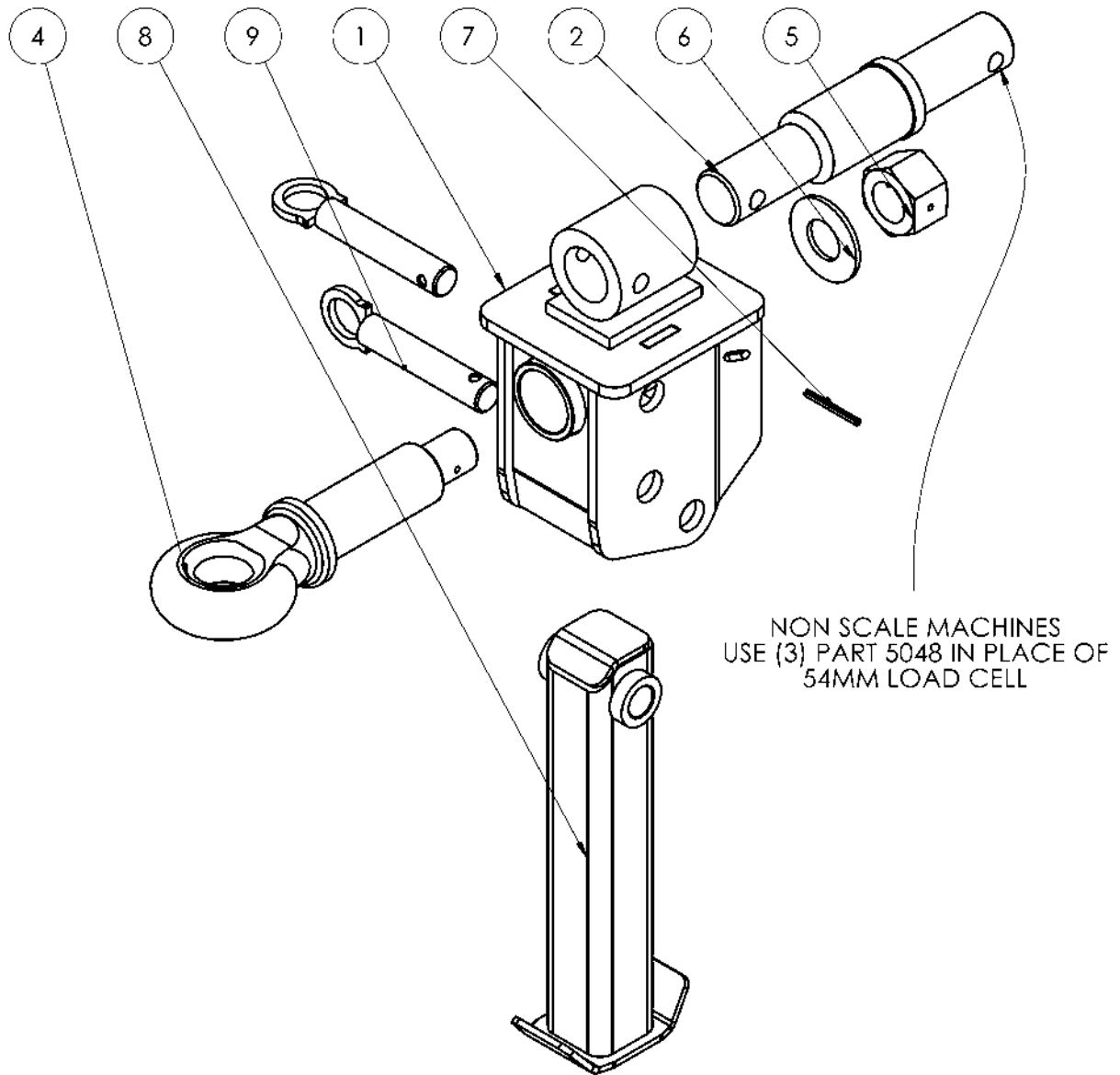

ITEM NO.	PART NUMBER	DESCRIPTION	QTY.
1	12565 - Load Cell Tow Eye Assy	Load Cell Tow Eye Assy	1
2	ES-DG8700/54	54MM LOAD CELL	1
3	50481	Load Cell Block	1
4	te-07.910		1
5	toe eye nut		1
6	Tow eye washer	Tow eye washer	1
7	Tow eye roll pin	Tow eye roll pin	1
8	12570 - Drawbar Foot	Drawbar Foot	1
9	12571 - Drawbar Foot Pin	Drawbar Foot Lock Pin	2

Tow Eye Assembly (MULTIPLUS 16, 19)

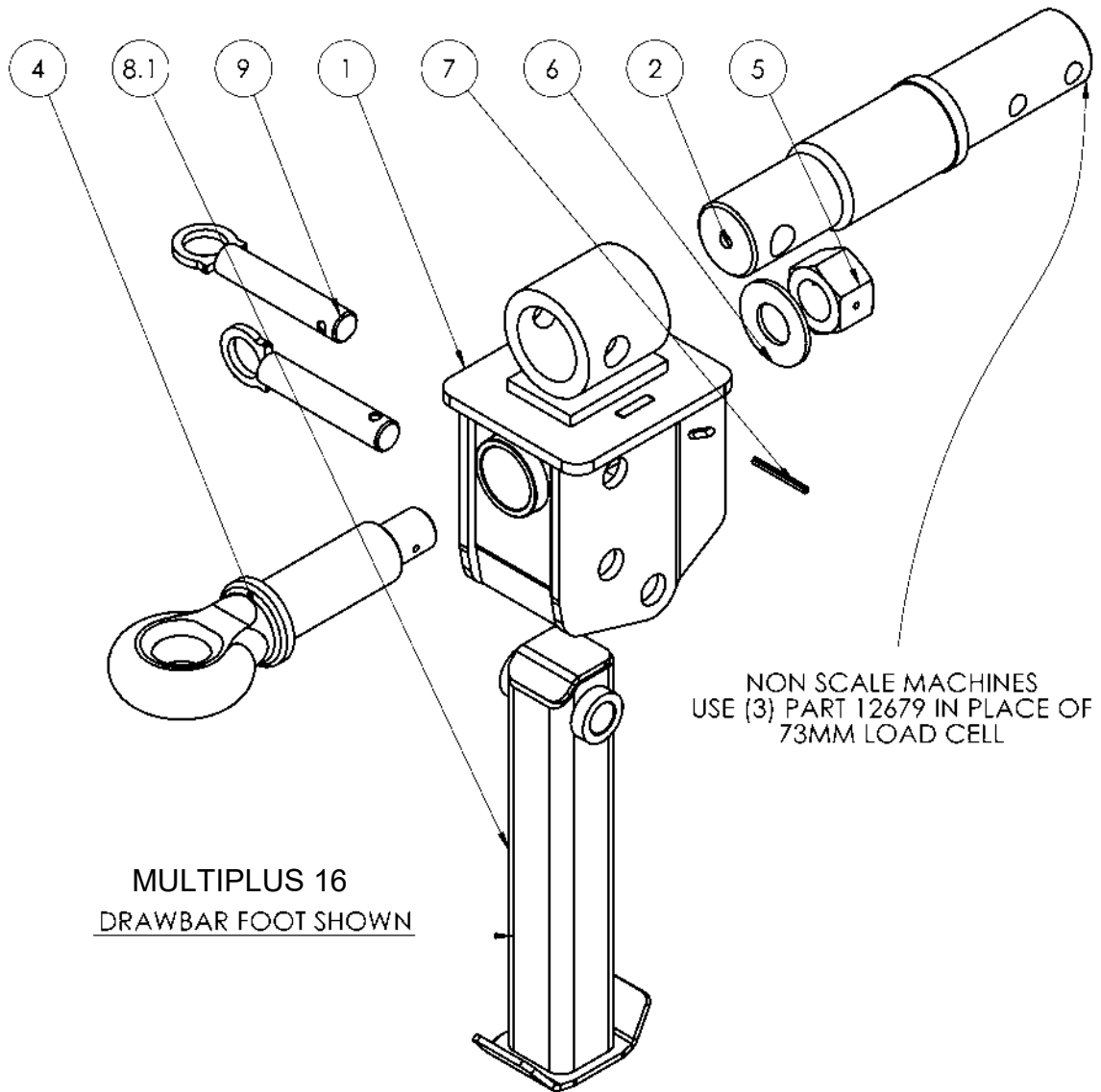

ITEM NO.	PART NUMBER	DESCRIPTION	QTY 5B	QTY 6B
1	12636 - 73mm Load Cell Tow Eye Assy	Load Cell Tow Eye Assy	1	1
2	ES-DG22000/73	73MM LOAD CELL	1	1
3	12679	Load Cell Block	1	1
4	te-07.910	Tow Eye	1	1
5	Tow eye nut	Tow Eye Nut	1	1
6	Tow eye washer	Tow eye washer	1	1
7	Tow eye roll pin	Tow eye roll pin	1	1
8.1	12570 - Drawbar Foot	Drawbar Foot	1	-
8.2	12643 - Drawbar Foot	Drawbar Foot	-	1
9	12571 - Drawbar Foot Pin	Drawbar Foot Lock Pin	2	2

Jack Assembly

RIMA Parking Jack

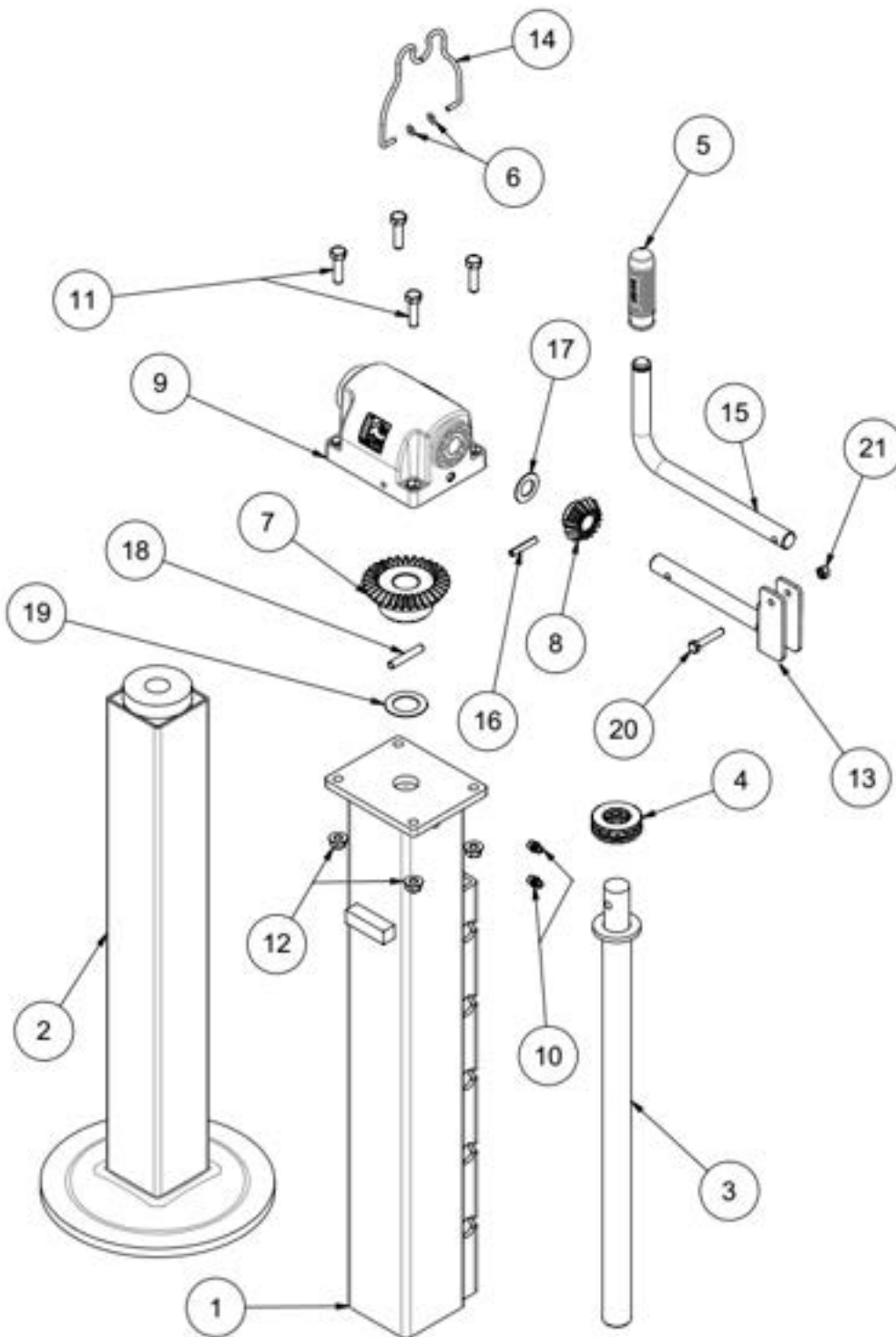

21	90064755	1
20	90076770	1
19	90068800	1
18	90070956	1
17	90068720	1
16	90071940	1
15	900411324	1
14	900416341	1
13	979303981	1
12	90064766	4
11	90079350	4
10	90039930	2
9	90049035	1
8	90033262	1
7	90033253	1
6	90069014	2
5	90041090	1
4	90034200	1
3	90057712	1
2	940655403	1
1	940275933	1
Item:	Code:	Q.ty:

Feed Unit Assembly

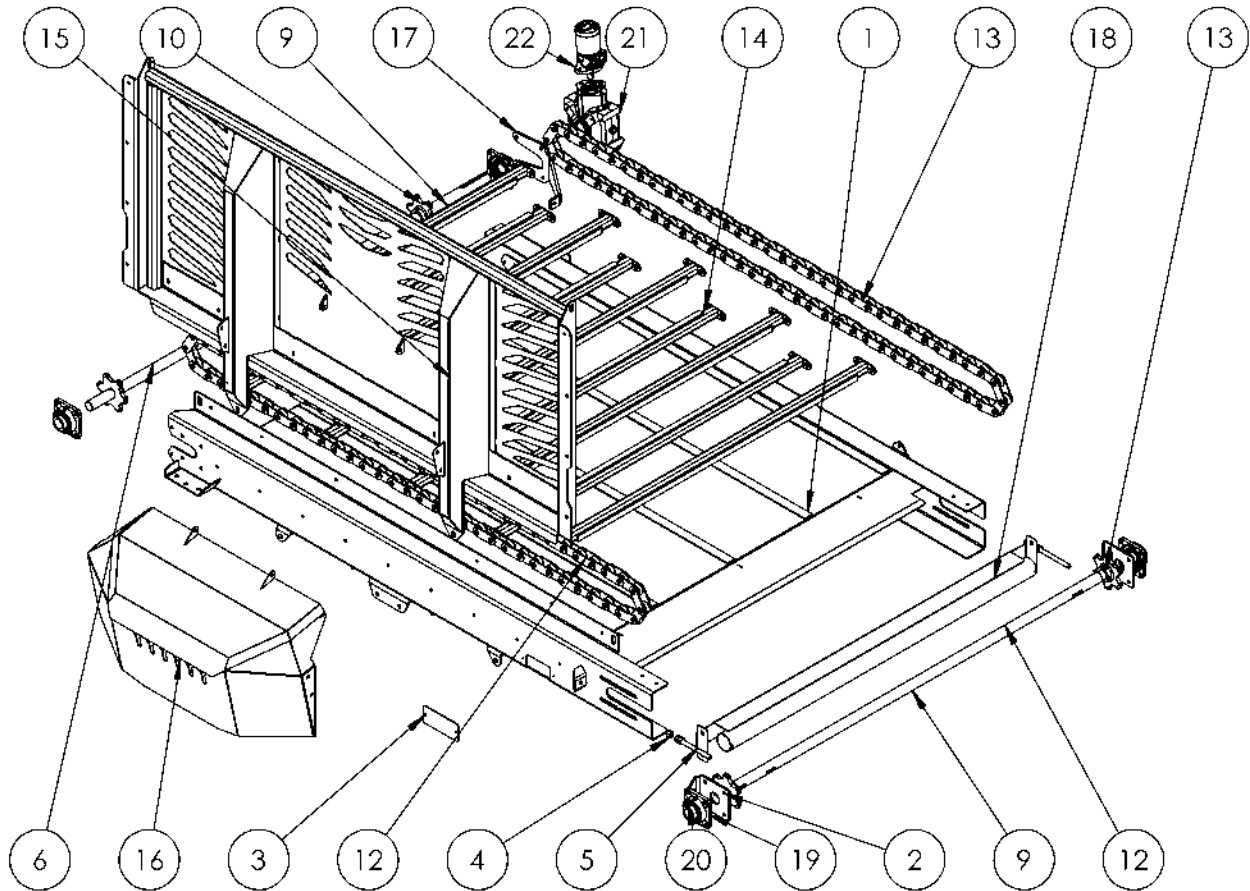

ITEM NO.	PART NUMBER	DESCRIPTION	QTY.
1	12582	CC Bed	1
2	12586-2	Bearing Adjuster	2
3	12586-8	Cover Plate	1
4	N16	M16 HEX	6
5	596-1004 adj screw	Adjuster Screw	2
6	12590 - Cross Conveyor Drive Shaft Assy	CC Drive Shaft Assy	1
7	12590-1	Cross Conveyor Drive Shaft	1
8	12620	6T 40mm Bore Sprocket	2
9	12591 - Cross Conveyor Idler Shaft Assy	CC Idler Shaft Assy	1
10	12591-1	Cross Conveyor Idle Shaft	1
11	12620	6T 40mm Bore Sprocket	2
12	12583	CC Chain & Bar Assy	1
13	Cross Conveyor Chain Assy	3" Pitch Roller Chain	2
14	12584 - Cross Conveyor Bar	Multifeeder CC Bar	11
15	12592	Front Wall Assy	1
16	12577	String Bin Assy	1
17	12564-3	CC Gearbox Mount	1
18	12564-2	CC Shaft Cover	1
19	HSGF208	Bearing Housing, 4 Bolt	4
20	BRGYET208	Bearing, 40mm w/ Locking Collar	4
21	GBRT120/40-PT	gearbox	1
22	HYM260-PT	Parker 260cc Hydraulic Motor	1

Elevator Assembly

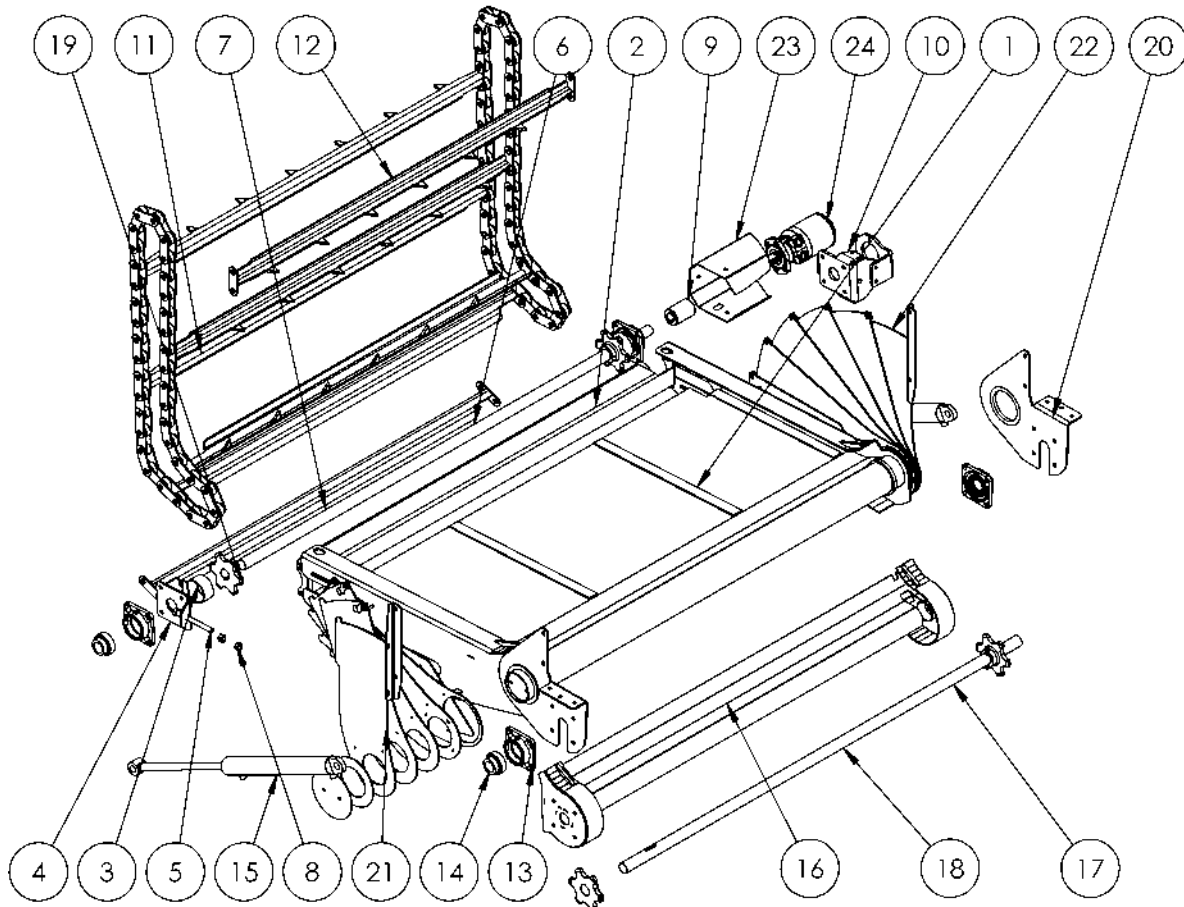

ITEM NO.	PART NUMBER	DESCRIPTION	QTY.
1	12756	Elevator Assy	1
2	13490	Elevator Drive Shaft Guard	1
3	12587-12	Sprocket Cover	2
4	12756-9	Bearing Adjuster	1
5	596-1004 adj screw	Adjuster Screw	2
6	12594 - Elevator Drive Shaft Assy	Elevator DShaft Assy	1
7	12594-1	Elevator Drive Shaft	1
8	N16	M16 HEX	6
9	13074	32 - 35 Shaft Coupling	1
10	13161	Motor Mount Assembly	1
11	12599	Elevator Chain & Bar Assy	1
12	12595L / 12595R	Multifeeder Elevator Bar	7
13	HSGF208	Bearing Housing, 4 Bolt	4
14	BRGYET208	Bearing, 40mm w/ Locking Collar	4
15	RAM2X1X459-DA	12760 - Multiplus Elevator Ram	2
16	12757	Lower Elevator Assy	1
17	12600 - Elevator Idler Shaft Assy	Elevator Idle Shaft Assy	1
18	12600-1	Elevator Idle Shaft	1
19	12620	6T 40mm Bore Sprocket	4
20	12758	Elevator Mount Assy	2
21	13022	Elevator Concertina Assy, RH	1
22	13407	Elevator Concertina Assy, LH	1
23	13146	Motor Guard	1
24	HYM500-PT	Parker TG0530 Hydraulic Motor	1

*Early machines fitted with 400cc motor use 127-2502 in place of Item 10, 13074

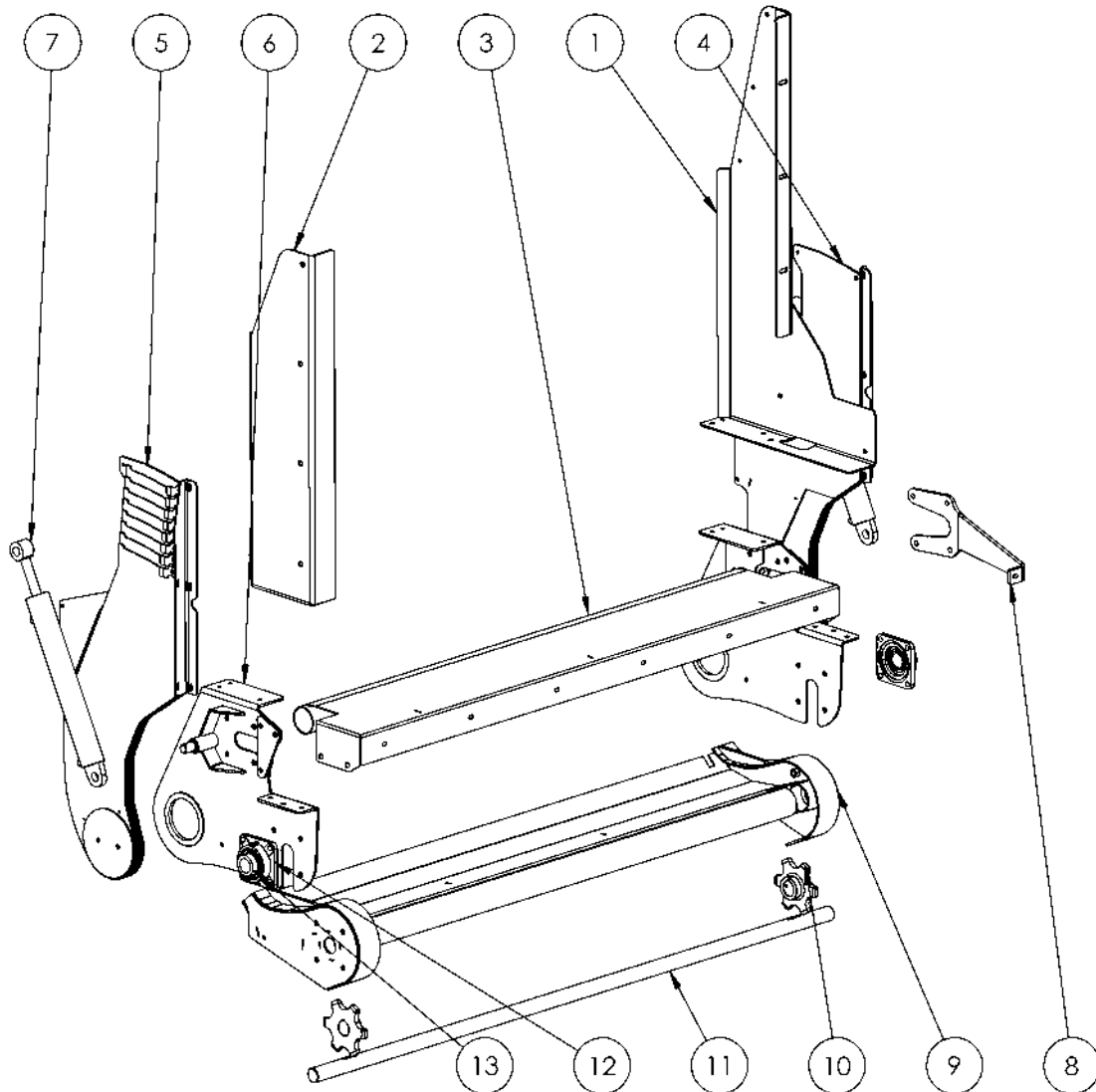

ITEM NO.	PART NUMBER	DESCRIPTION	
1	13802	SKF 40mm Y Bearing	1
2	13801	Elevator Fill Plate, Front	1
3	13795-1	Cross Conveyor Drive Shaft Cover	1
4	13799	RH Concertina Assembly	1
5	13805	LH Concertina Assembly	1
6	13798	Elevator Mount Assembly	2
7	RAM2X1X375	Multiplus Elevator Ram, 375mm Stroke	2
8	13796	Gearbox Mount, Extended	1
9	13797	Extended Lower Elevator Assembly	1
10	12620	6th Cast Sprocket, 40mm bore	2
11	12600-1	Multiplus Elevator Idler Sprocket	1
12	HSGF208	4 Bolt Bearing Housing	2
13	BRGYET208	Bearing, 40mm w/ Locking Collar	2

Cross Conveyor Extension Assembly

*Fitted to machines manufactured after June 2021

Rear Gate Assembly

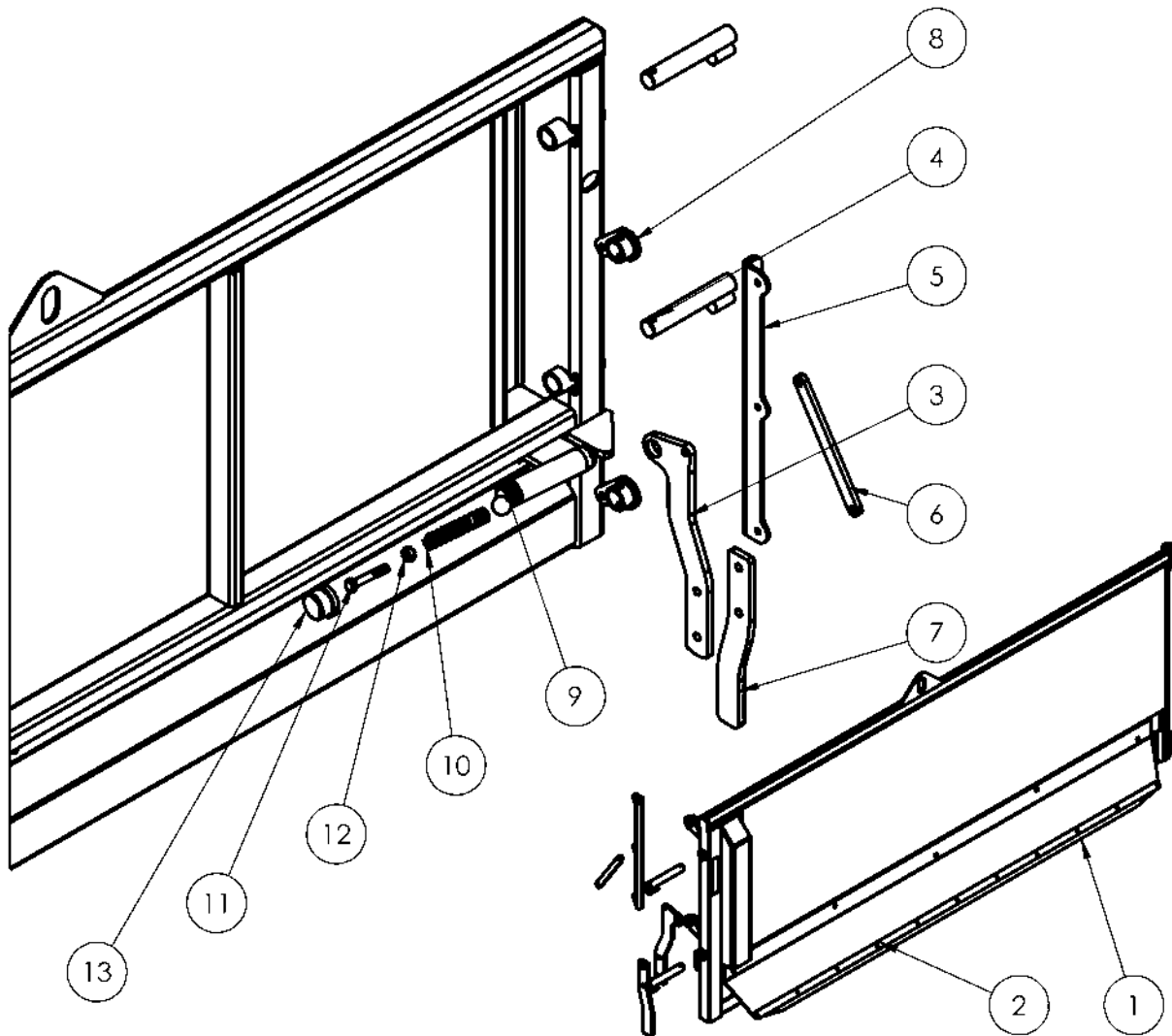

ITEM NO.	PART NUMBER	DESCRIPTION	QTY.
1	12568-1	Seal Strip Plate	1
2	12568-3	Retaining Strip	1
3	12568-5	Latch Lever	1
4	12568-6	Locking Rod	2
5	12568-7	Latch Link	1
6	12568-8	Latch Pushrod	1
7	12568-12	Lever Handle	1
8	12652 - Tailgate Collar		2
9	BRGUC1	Ball Bearing, 1"	1
10	SGC100X24	Spring, Compression	1
11	B10X65	M10 X 65 Bolt	1
12	NN10	NUT, NYLOC M10	1
13	PFCAP25G	Cap, Galvanised	1

Side Gate Assembly

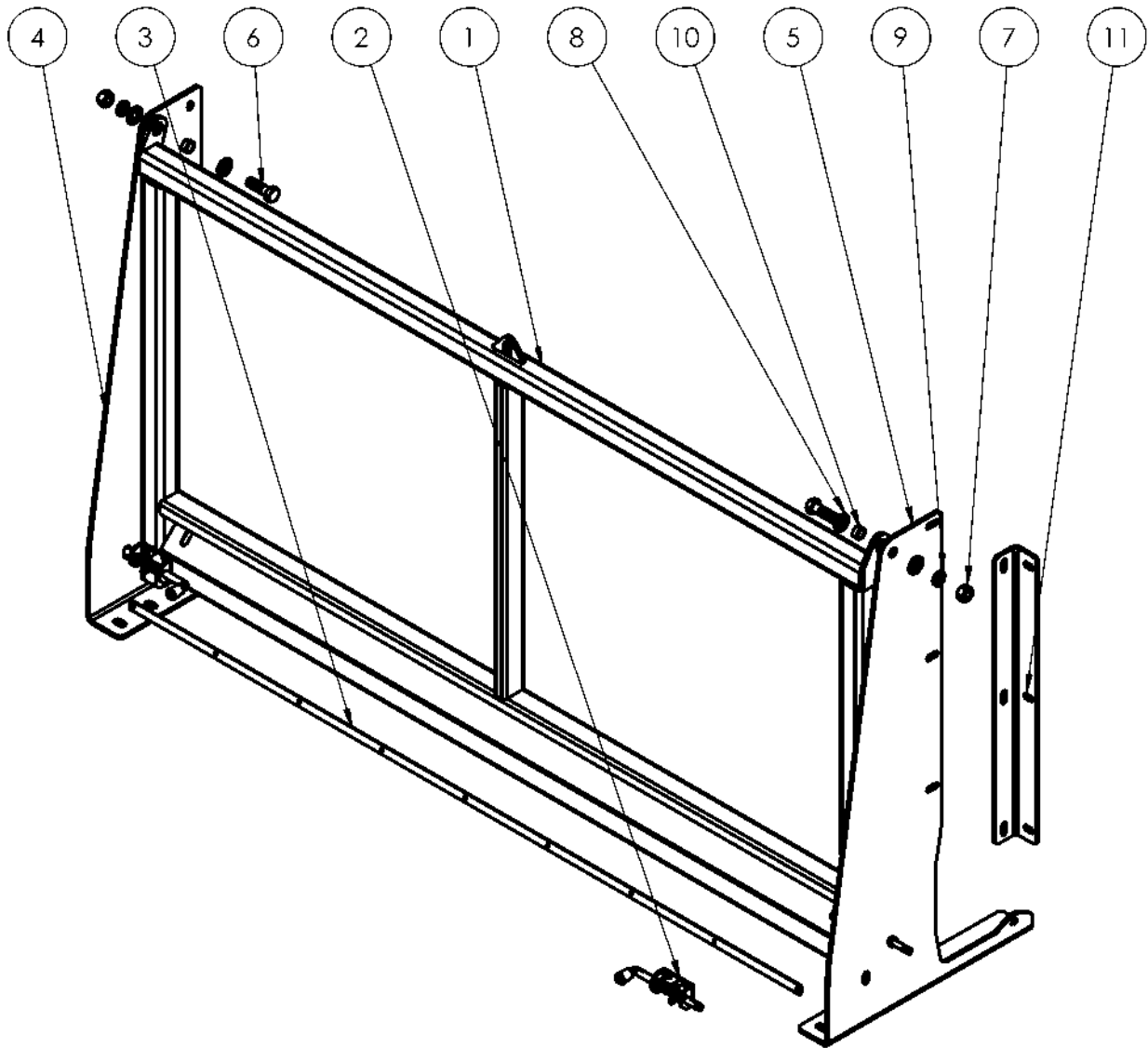

ITEM NO.	PART NUMBER	DESCRIPTION	QTY.
1	12601 - Side Top Hinge Gate	Top Hinge Gate Assy	1
2	COMAC4518	Pin Spring Bolt 12mm	2
3	12573-5	Retainer Strip	1
4	12573-1	Front Gate Panel	1
5	12573-2	Rear Gate Panel	1
6	B16X50	M16 X 50 Bolt	2
7	N16	M16 HEX	2
8	WA16	M16 Washer	4
9	WASG16	M16 SPRING	2
10	12573-3	Door Bolt Bushing	2
11	12573-4	Angle Mount	1

Shredder Assembly – Optional

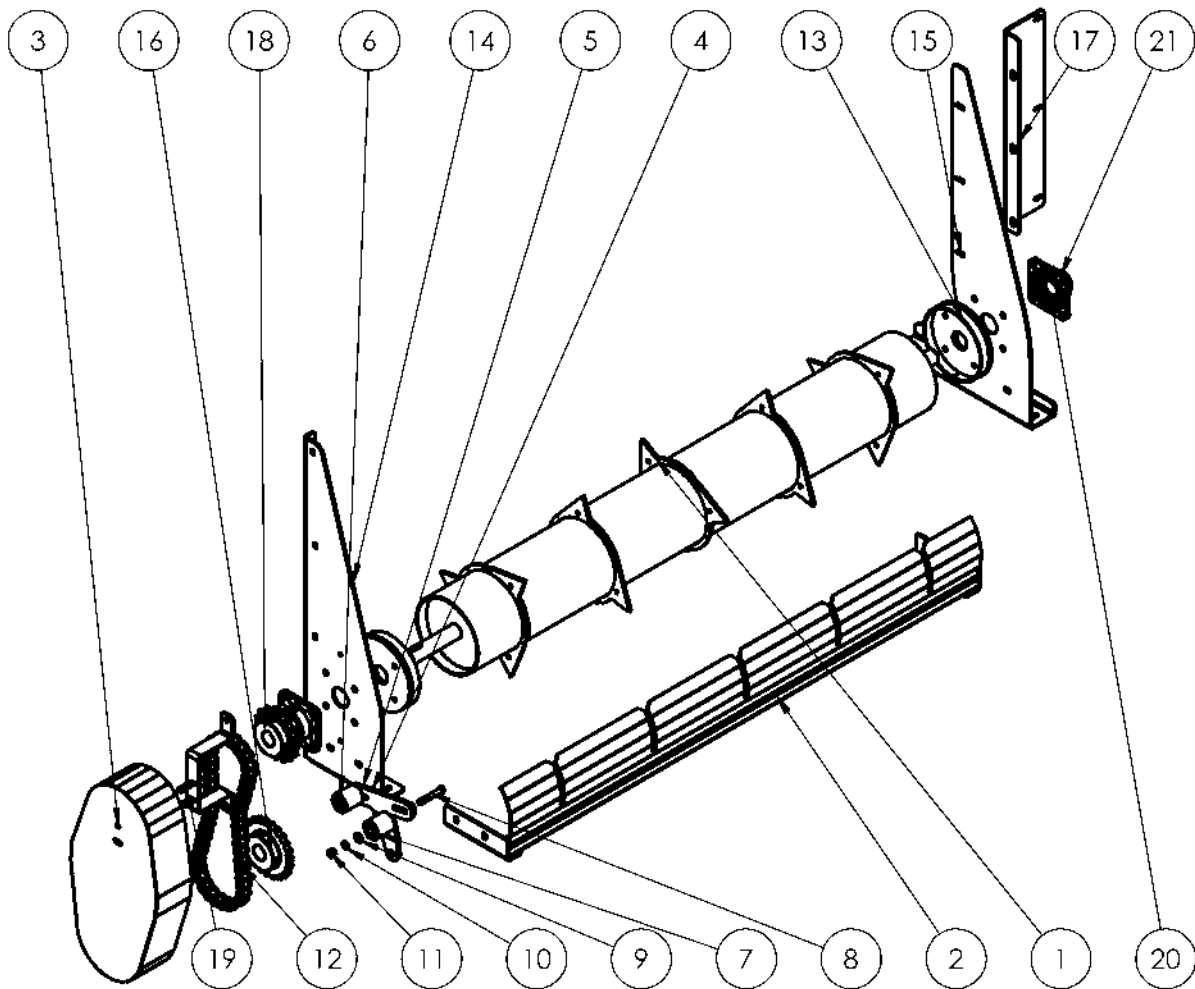

ITEM NO.	PART NUMBER	DESCRIPTION	QTY.
1	12597	Shredder Shaft Assy	1
2	12598	Shredder Scraper Assy	1
3	12974 - Shredder Chain Cover Assy	Chain Guard	1
4	12644 - Shredder Chain Tensioner	Chain Tensioner	1
5	12644-1	Chain Tensioner Profile	1
6	595-1062 ass	tension roller assy	2
7	595-1062	Roller	1
8	B12X75	M12 X 75 Bolt	1
9	WA12	M12 Washer	2
10	WASG12	M12 Spring Washer	1
11	N12	M12 Nut	1
12	CH16B	16B 1" Pitch Chain	1
13	12596-1	Shaft Ring	2
14	12596-2	Front Mount Panel	1
15	12596-3	Rear Shredder Panel	1
16	12596-4	16B 23T Shredder Sprocket	1
17	12596-5	Mount Plate	1
18	12596-6	16B 17T Shredder Sprocket	1
19	12596-7	Chain Guard Mount	1
20	BRGYAR208-2F	Bearing, 40mm	2
21	HSGF208	Bearing Housing, 4 Bolt	2

Panels, Guards & Covers

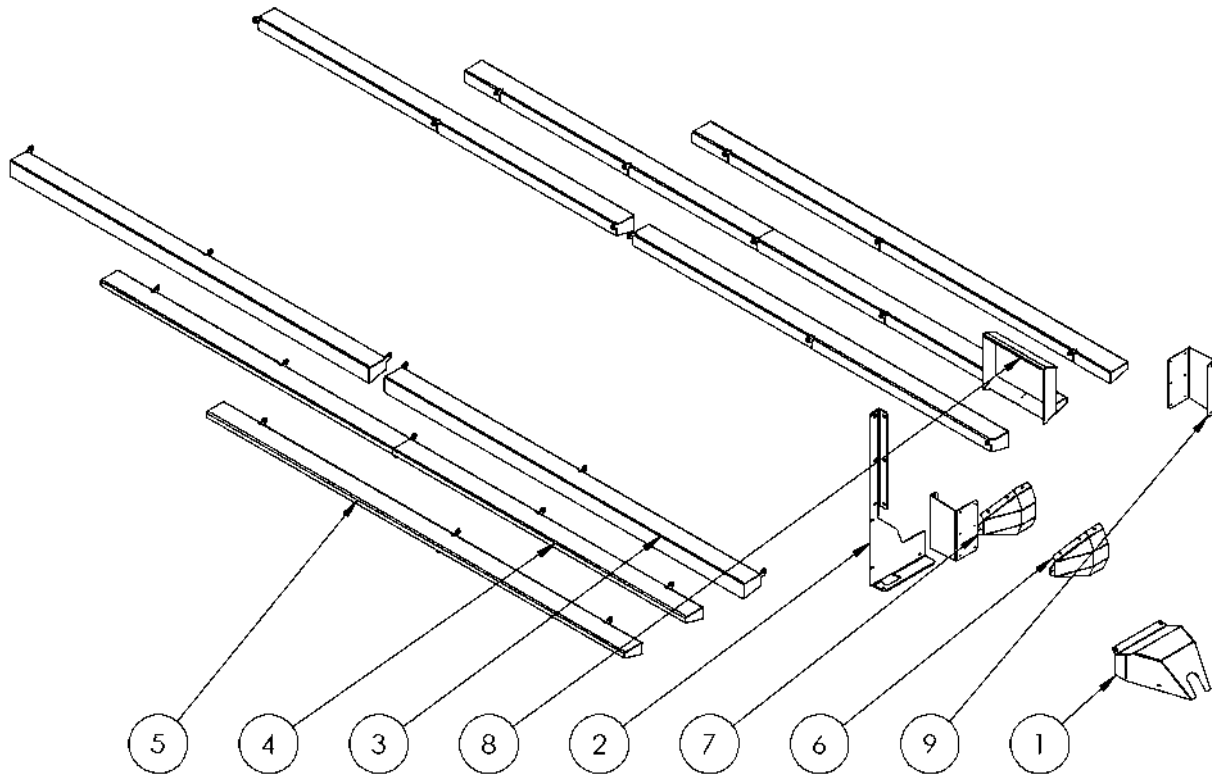

ITEM NO.	PART NUMBER	DESCRIPTION	MP13 QTY.	MP16 QTY.	MP19 QTY.
1	12677	Valve Block Cover	1	1	1
2	12641	Elevator Fill Plate	1	1	1
3	12687	MP18 Mudguard Extension	-	-	4
4	12648	MP16 Mudguard Extension	-	2	-
5	12653	MP13 Mudguard Extension	2	-	-
6	12658	4 Chain Gearbox Guard	-	1	1
7	12657	2 Chain Gearbox Guard	1	-	-
8	12670-3	Enclosure Cover	1	1	1
9	12798L/12798R	Hazard Panel Mount	2	2	2

*Early machines use 12656 - Valve block cover (separate stainless mount bolted to drawbar) in place of Item 1, 12677

*Item 8 only fitted to machines with scales

*Item 9 only fitted to machines with Visibility Kit

Floor Transmission – Two Chain Models (MULTIPLUS 13)

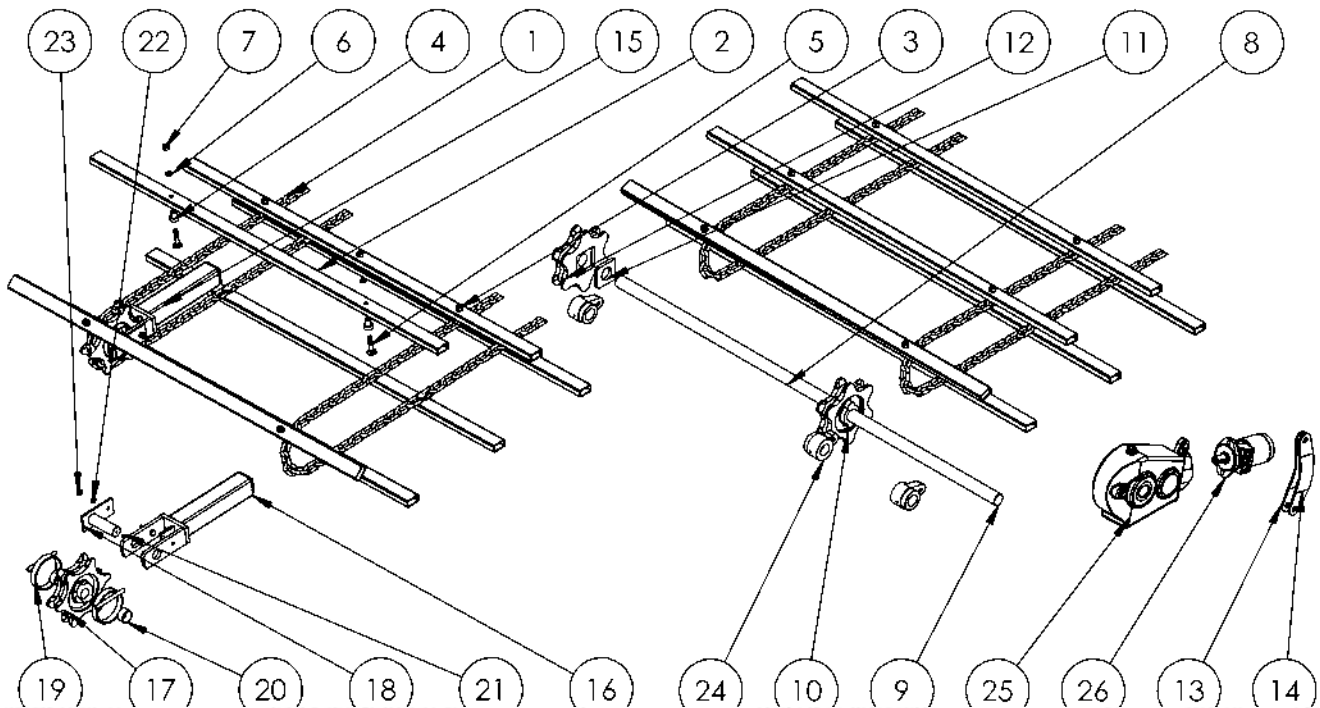

ITEM NO.	PART NUMBER	DESCRIPTION	QTY.
1	CH10HTLL	Chain 10mm High Tensile Long Link	8.5m/85 Links
2	605-2030	Floor Slat, RF Series, 4 Chain	46
3	605-3000	Bush Assembly	92
4	605-3001-1	Chain Attachment Bush	1
5	BCH12x60	M12X60 Coach Bolt	1
6	WASG12	M12 Spring Washer	1
7	N12	M12 Nut	1
8	12567 - 4B Front Drive Shaft Assy	Front Drive Shaft Assy	1
9	12567-1	4B Drive Shaft	1
10	210-0020	Sprocket c/w Drive Plate	4
11	211-0114	Sprocket Drive Plate	1
12	CSTSPKT6D-SGSQ	Sprocket	1
13	12578 - Gearbox Torque Arm Assy		1
14	12578-1	Gearbox Torque Arm	2
15	571-0085	Rear Idler Assembly	4
16	571-0087	Adjuster Frame	1
17	210-0012	Idle Sprocket	1
18	597-1029-1	6TH IDLER AXLE ASSY (MAY '02 ON)	1
19	597-1036	Shaft Wrapping Guard	2
20	625-0040	Sprocket Spacer	2
21	GRN8-ST	GREASE NIPPLE	1
22	WASG10	M10 Spring washer	1
23	N10	M10 Nut	1
24	615-2002_	∅40mm Shaft Deadeye	3
25	GBRT200-40-PT	gearbox	1
26	HYM260-PT	PARKER 260CC Hydraulic Motor	1

Floor Transmission – Four Chain Models (MULTIPLUS 16, 19)

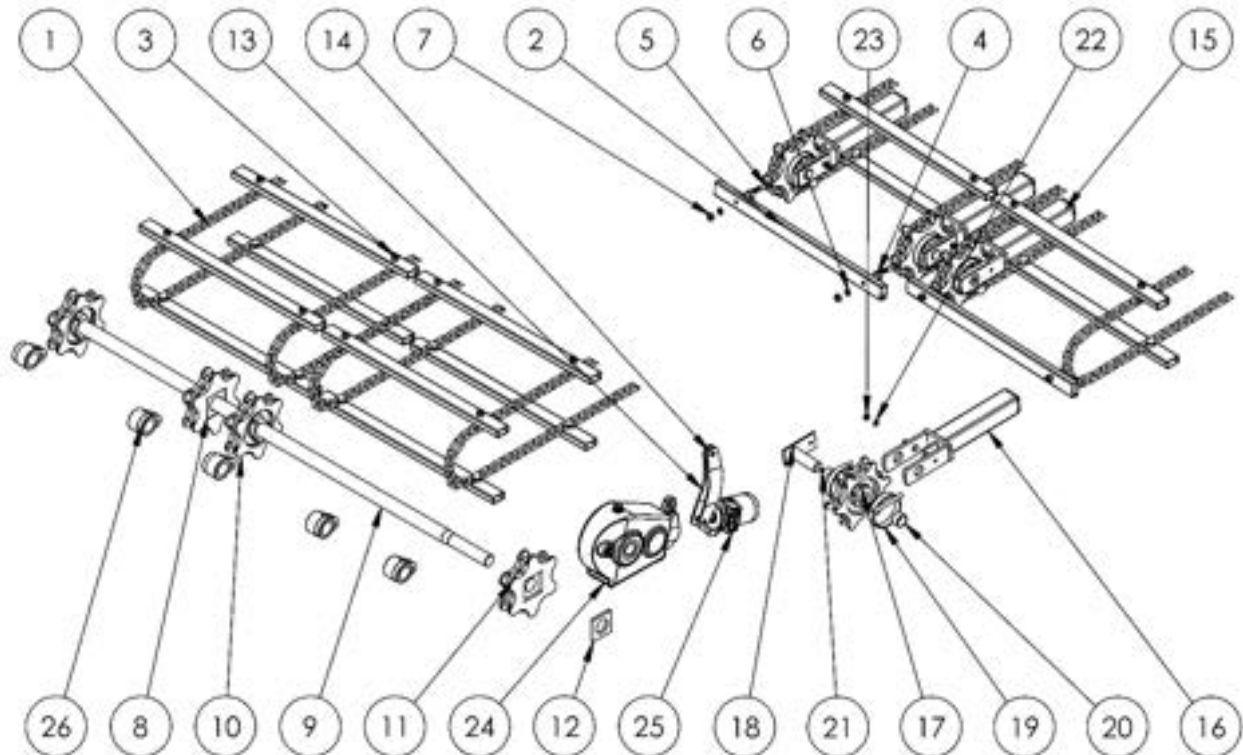

ITEM NO.	PART NUMBER	DESCRIPTION	QTY. (58 / 68)
1	CH10HTLL	Chain 10mm HT Long Link	10.9m/13.2m 109 Links/132 Links
2	605-2030	Floor Stat, RF Series, 4 Chain	54 / 66
3	605-3000	Bush Assembly	108 / 132
4	605-3001-1	Chain Attachment Bush	1
5	BCH12x60	M12X60 Coach Bolt	1
6	WASG12	M12 Spring Washer	1
7	N12	M12 Nut	1
8	12632 - 58 Front Drive Shaft Assy	Front Drive Shaft Assy	1
9	12632-1	58 Driveshaft	1
10	210-0030	Drive Sprocket c/w Drive Plate	4
11	CSTSPKT6D-SGSQ	Sprocket	1
12	211-0121	Sprocket Drive Plate	1
13	12578 - Gearbox Torque Arm Assy		1
14	12578-1	Gearbox Torque Arm	2
15	571-0085	Rear Idler Assembly	4
16	571-0087	Adjuster Frame	1
17	210-0012	Idle Sprocket	1
18	597-1029-1	6TH IDLER AXLE ASSY (MAY '02 ON)	1
19	597-1036	Shaft Wrapping Guard	2
20	625-0040	Sprocket Spacer	2
21	GRN8-ST	GREASE NIPPLE	1
22	WASG10	M10 Spring washer	1
23	N10	M10 Nut	1
24	GBRT200-40-PT	gearbox	1
25	HYM260-PT	Parker 260cc Hydraulic Motor	1
26	615-2023-1.00-45mm deadeye bearing	Ø 45mm Shaft Deadeye	5

Axle / Subframe Assembly – MULTIPLUS 13

- Parts list applies to all machines fitted with standard 400 X 15.5 Tyres

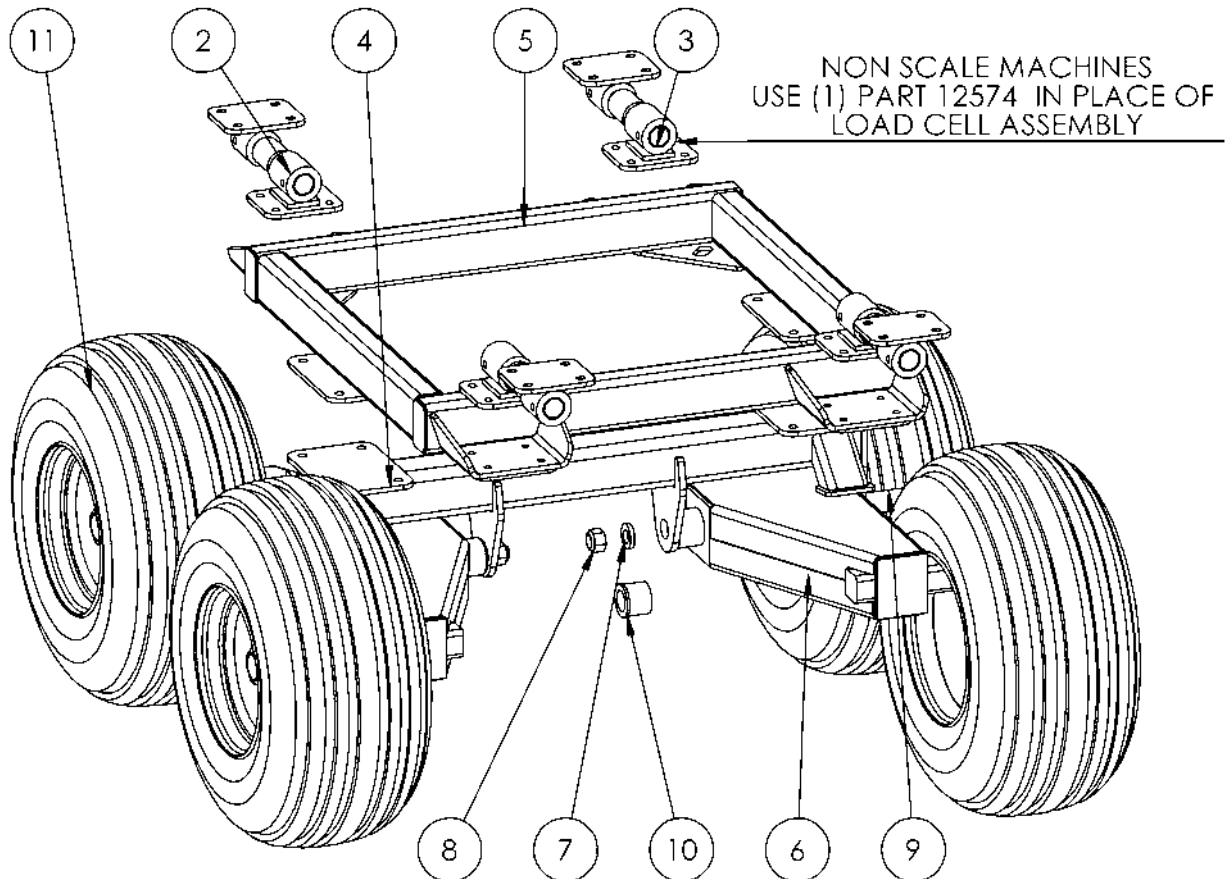

ITEM NO.	PART NUMBER	DESCRIPTION	QTY.
1	12574	Load Cell Spacer Assy	4
2	12569 - Multifeeder Load Cell Assy	Load Cell Assy	4
3	ES-DG8700/54	54MM LOAD CELL	4
4	12580 - Axle Beam Assy	Axle Beam Assy	1
5	12581 - 4B Axle Subframe	Axle Subframe	1
6	50334	Walking Beam Axle Assembly	2
7	50045 axle pivot washer	Axle Pivot Washer	2
8	NNF1-1/4	Nylock nut 1.25 UNF	2
9	BEAPHD	Axle Shaft	2
10	C28176 axle bush	Axle Bush	4
11	400x15.5		4

Axle / Subframe Assembly – MULTIPLUS 16

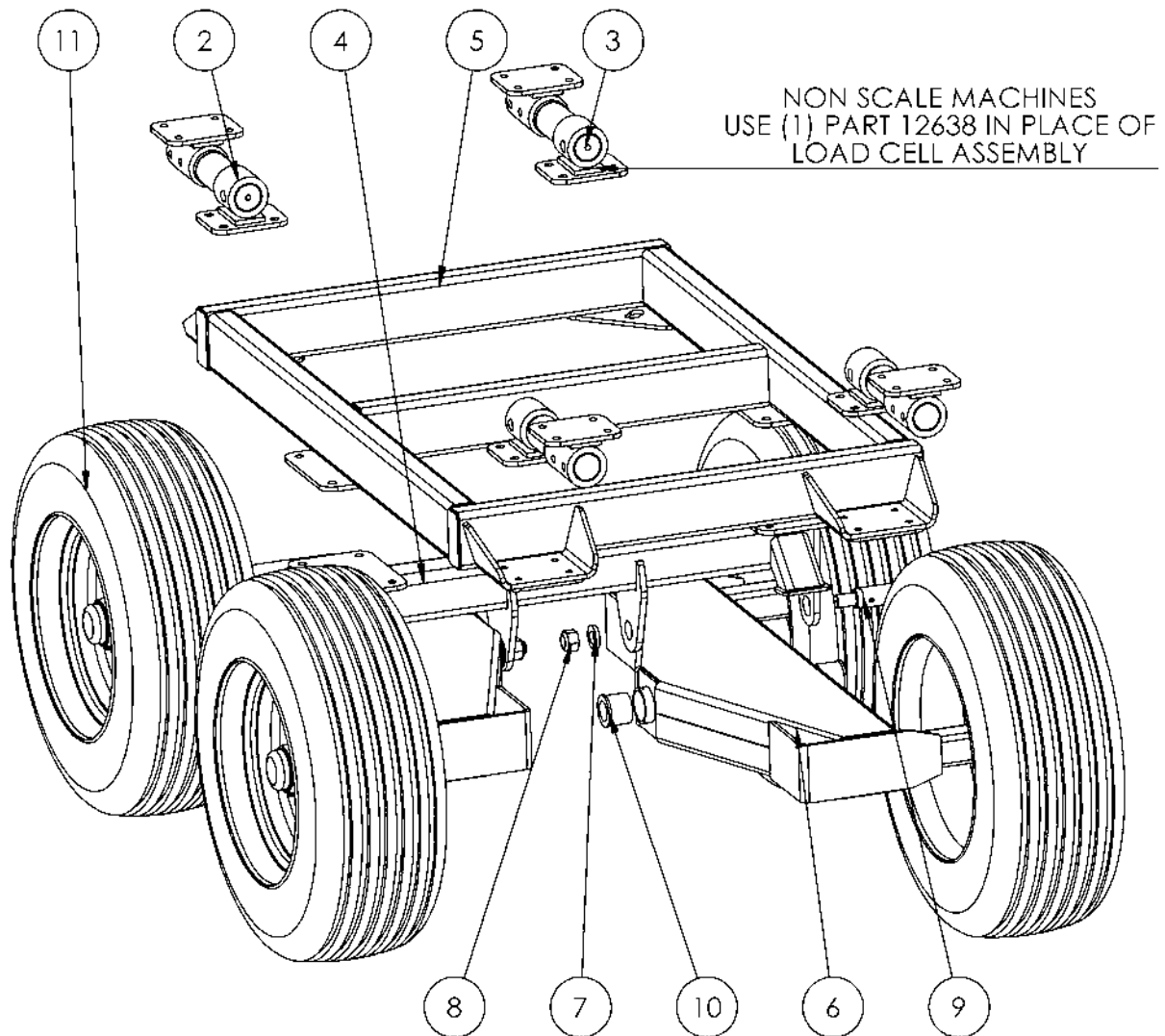

ITEM NO.	PART NUMBER	DESCRIPTION	QTY.
1	12638	Load Cell Spacer Assy	4
2	12637 - 73mm Load Cell Assy	Load Cell Assy	4
3	ES-DG22000/73	73MM LOAD CELL	4
4	12633 - Axle Beam Assy	Axle Beam Assy	1
5	12634 - 5B Axle Subframe	Axle Subframe	1
6	50524 Axle beam welded assy	Walking Beam Assy	2
7	50045 axle pivot washer	Axle Pivot Washer	2
8	NNF1-1/4	Nylock nut 1.25 UNF	2
9	BEAPHD	Axle Shaft	2
10	C28176 axle bush	Axle Bush	4
11	15.70-18		4

- Parts list applies to all machines fitted with standard 15.0 / 70 - 18 Tyres

Axle / Subframe Assembly – MULTIPLUS 19

- Parts list applies to all machines fitted with standard 500 / 60 – 22.5 Tyres

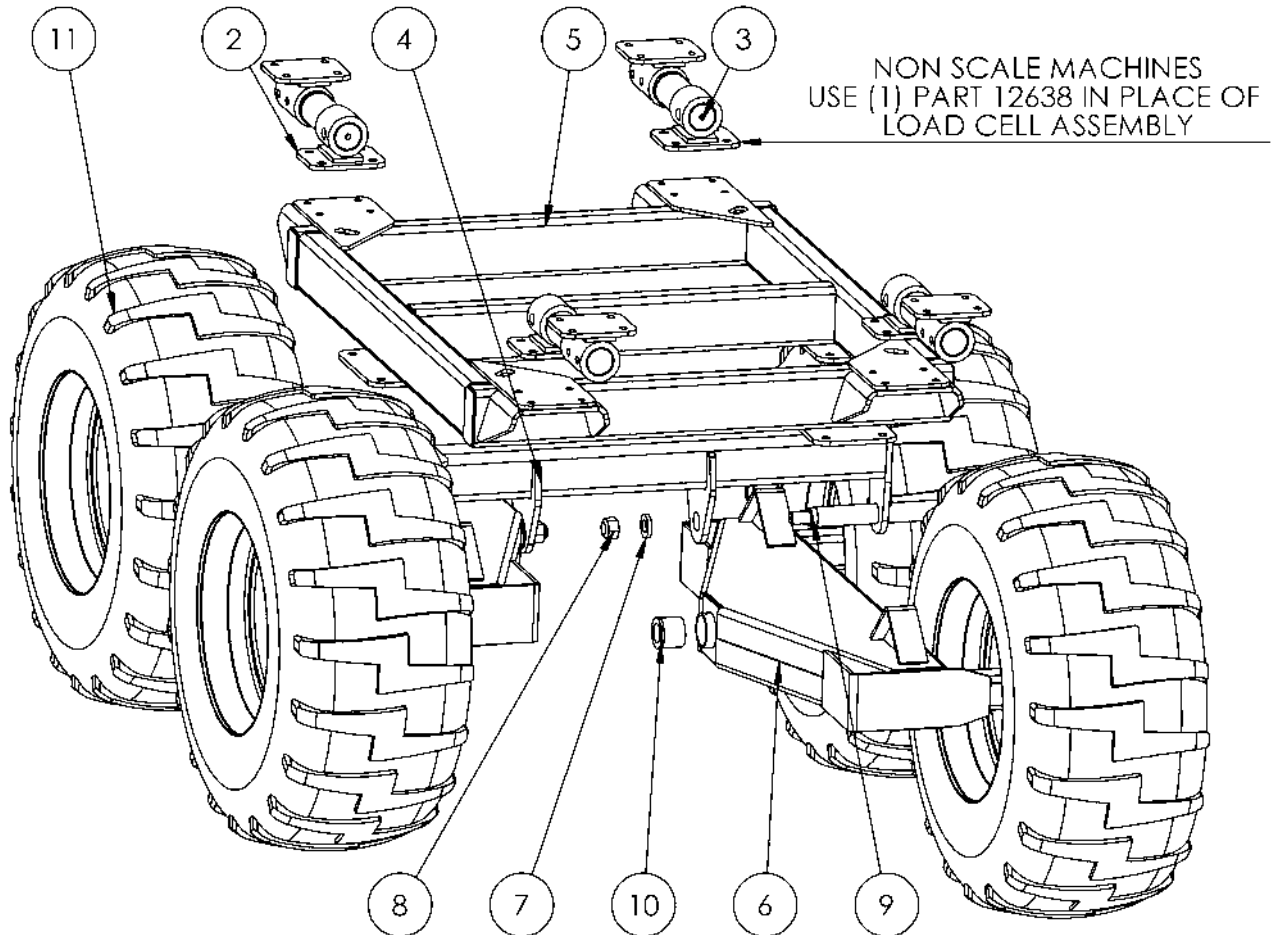

ITEM NO.	PART NUMBER	DESCRIPTION	QTY.
1	12638	Load Cell Spacer Assy	4
2	12637 - 73mm Load Cell Assy	Load Cell Assy	4
3	ES-DG22000/73	73MM LOAD CELL	4
4	12684 - Axle Beam Assy	Axle Beam Assy	1
5	12685 - 6B Axle Subframe	Axle Subframe	1
6	50797 Axle Beam Welded Assy	Walking Beam Assy	2
7	50045 axle pivot washer	Axle Pivot Washer	2
8	NNF1-1/4	Nylock nut 1.25 UNF	2
9	BEAPHD	Axle Shaft	2
10	C28176 axle bush	Axle Bush	4
11	500.60-22.5		4

Hub Assembly – ADR

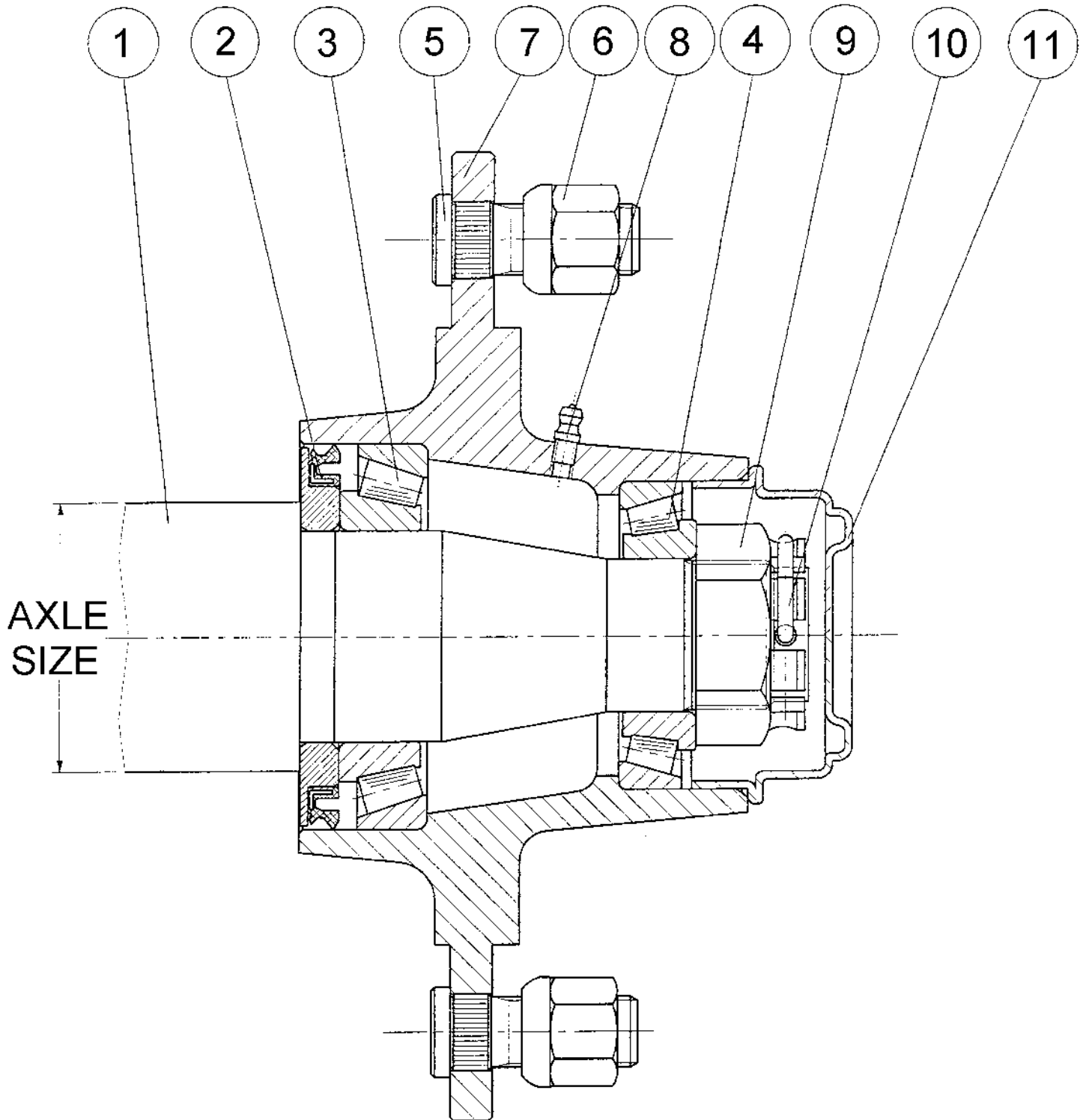

Item	Giltrap Part #	Description	Quantity		
			70mm	80mm	90mm
1	HUB3000KG	Complete Stub Axle, ADR 6	1		
1	HUB4250KG	Complete Stub Axle, ADR 8		1	
1	HUB5000KG	Complete Stub Axle, ADR 8			1
2	110-0194	Seal 67x120x12 O/A	1		
2	110-0195	Seal 78x130x10 O/A		1	
2	110-0196	Seal 82x140x10 O/A			1
3	BRG32210J2	Taper Roller Bearing, 32210 J2	1		
3	BRG32212J2	Taper Roller Bearing, 32212 J2		1	
3	BRG32213J2	Taper Roller Bearing, 32213 J2			1
4	BRG30213J2	Taper Roller Bearing, 30213 J2	1		
4	BRG32215J2	Taper Roller Bearing, 32215 J2		1	
4	BRG32216J2	Taper Roller Bearing, 32216 J2			1
5	110-0945	Wheel Stud, M18x50	6	8	
5	110-0950	Wheel Stud, M20x60x1.5			8
6	110-0917	Wheel Nut, M18	6	8	
6	110-0919	Wheel Nut, M20x1.5			8
7	-	Hub Only	1	1	1
8	GRN8-45	Grease Nipple, M8x1.0 45 deg	1	1	1
9	110-1047	Slotted Nut, M39x1.5	1		
9	110-1060	Slotted Washer Nut, M48x1.5		1	1
10	-	Retaining Clip (or Split Pin	1		
10	-	Retaining Clip (or Split Pin		1	
10	-	Retaining Clip (or Split Pin			1
11	110-0881	Grease Cap ADR Pressed	1		
11	110-0883	Grease Cap ADR Pressed		1	
11	110-0884	Grease Cap ADR Pressed			1

Gearbox

Berma RT120

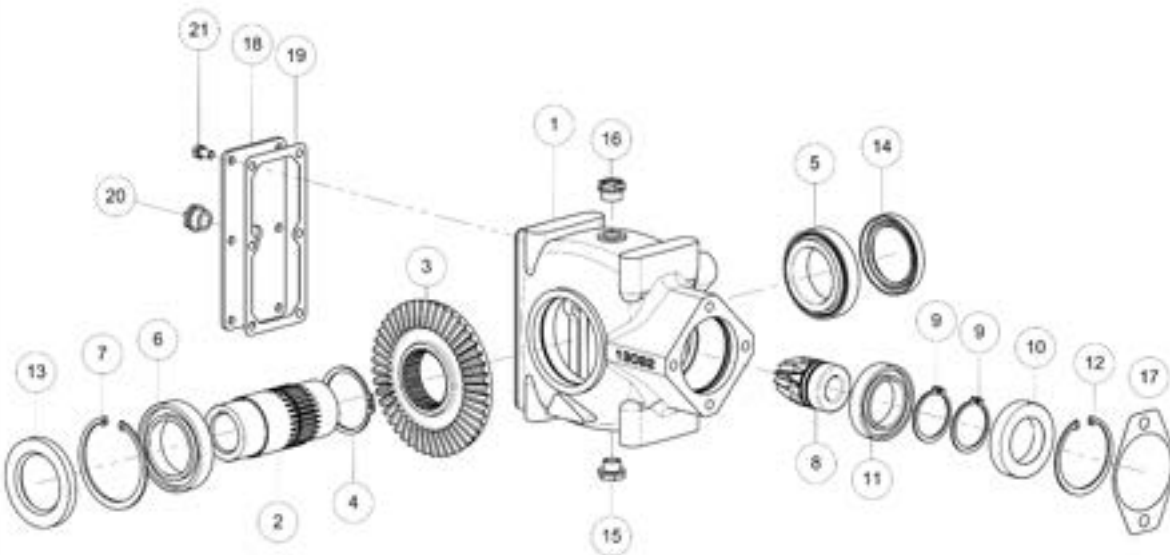

Riduttore RT120 Ø40

CODICE 13039

Fig.	Rif.	Descrizione	Qt.
1	13092	Scatola RT120	1
2	13094	Mozzo Ø40	1
3	13093	Corona Z=45	1
4	3429	Seeger E 65	1
5	13109	Cuscinetto 32012	1
6	3353	Cuscinetto 6012	1
7	3438	Seeger I 95	1
8	13091	Pignone Z=11	1
9	13108	Seeger E 50x3 rinf.	2
10	10552	Cuscinetto 6010-2RS	1
11	1538	Cuscinetto 6010	1
12	3435	Seeger I 80	1
13	8889	Anello di ten. 60/65/10	1
14	3660	Anello di ten. 60/85/10	1
15	1714	Tappo scarico Ø1/2"Gas	1
16	5689	Tappo sfiato Ø1/2"Gas	1
17	8671	Guarnizione x motore	1
18	13097	Coperchio	1
19	13107	Guarnizione coperchio	1
20	1257	Spia liv. olio Ø1/2"Gas	1
21	3284	Vite TE M8x16-6G	6

Berma RT200

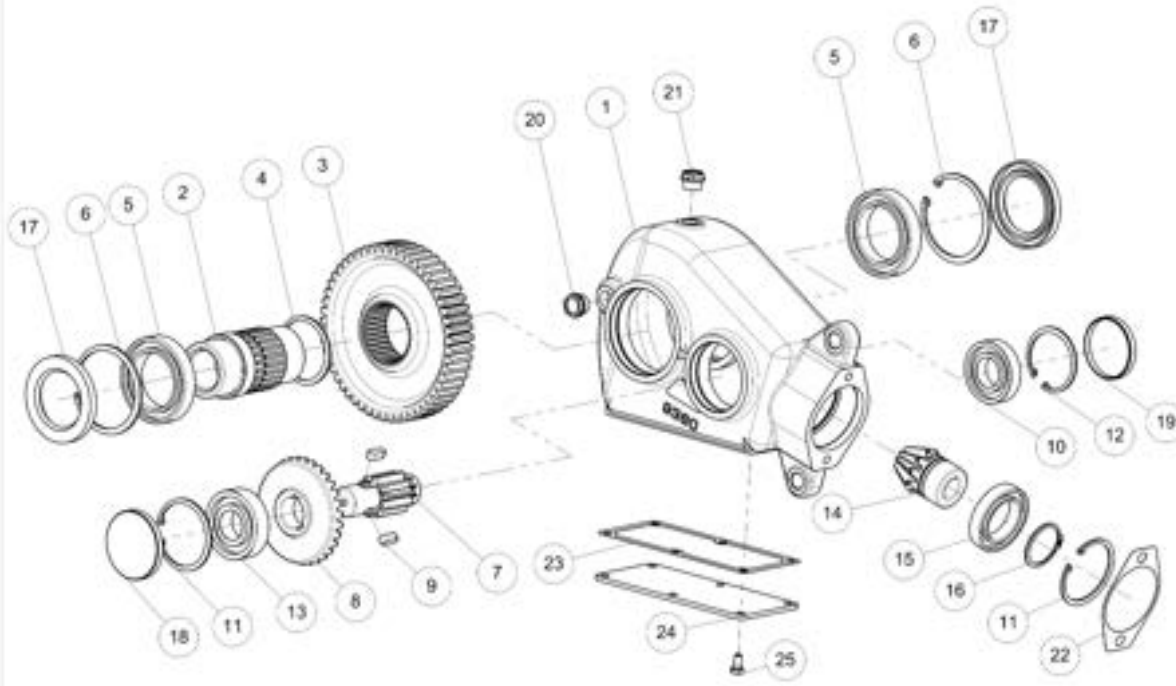

Riduttore RT200 Ø45

CODICE 9358

Fig.	Rif.	Descrizione	Qt.
1	9360	Scatola RT200	1
2	8670-8	Mozzo Ø45	1
3	9347	Ruota dentata Z=53	1
4	8703	Seeger E 72	1
5	8702	Cuscinetto 6013	2
6	3439	Seeger I 100	2
7	9346	Pignone di rinvio Z=10	1
8	9359	Corona Z=31	1
9	3401	Chiavetta 10x8x25	2
10	3333	Cuscinetto 6207	1
11	3435	Seeger I 80	2
12	3434	Seeger I 72	1
13	3339	Cuscinetto 6307	1
14	9255	Pignone Z=10	1
15	1538	Cuscinetto 6010	1
16	3428	Seeger E 50	1
17	8701	Anello di ten. 65/100/10	2
18	8243	Tappo Ø60 sp.10	1
19	8490	Tappo Ø72 sp.10	1
20	1257	Spia liv. olio Ø1/2"Gas	1
21	5689	Tappo sfuato Ø1/2"Gas	1
22	8671	Guarnizione x motore	1
23	9361	Guarnizione coperchio	1
24	9362	Coperchio	1
25	3284	Vite TE M8x16-8G	6

Brake Hose & Cylinder Configurations

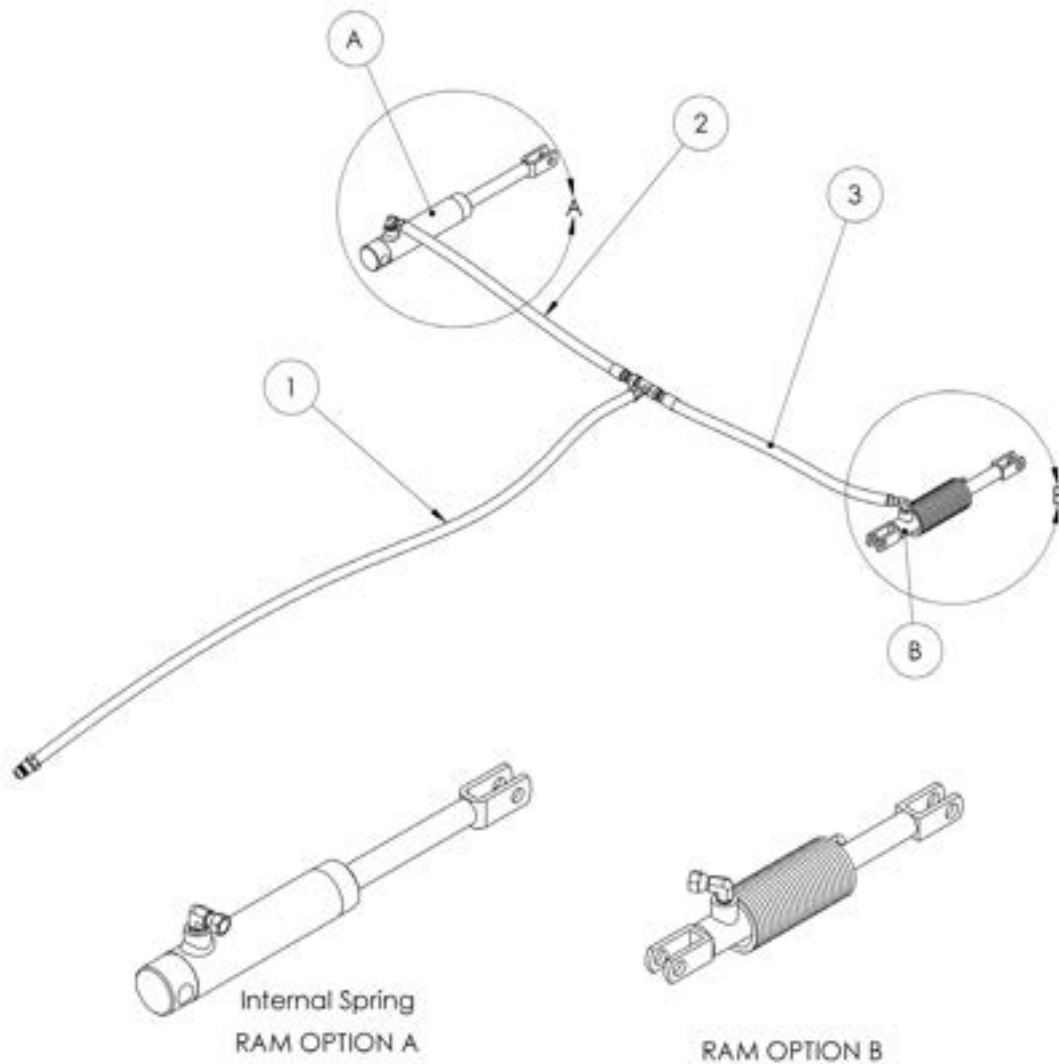

Item No	Part Number	Description	Quantity
A	RAMAX94125S-PT	Type A Brake Ram	2
B	RAMADR030/025-PT	Type B Brake Ram	2

Notes