

65 YEARS

100%
MADE IN
NZ



Giltrap Pro-Series Spreader

Operation & Parts Manual



Disclaimer

Although every endeavour has been made to compile as near to complete records as possible for the machine described, it is possible some information is incomplete or missing.

Giltrap Engineering request that you treat this book as a guide only and offer any assistance necessary to procure the information or part you may require.

For parts or service enquiries, please contact the applicable numbers on the previous page.

General Description of Machine

The GILTRAP ENGINEERING Orchard Spreader, 3T-2501, 4T-3802, 6T-5001, 8T-6601, and 10T-8301 are fertiliser spreading machines, used for spreading fertiliser or similar products behind a towing tractor, usually in an agricultural environment. All the machines have identical operating procedures, and they all require a remote power source to provide motive power and hydraulic pressure. The machines operate by dropping product off a belt onto the two spinners. The spinners spread fertiliser behind the machine while being towed behind an agricultural tractor. The towing tractor provides all motive power, including the hydraulic power. These machines are constructed from 5 to 9mm wall thickness box section for the chassis and 3 to 8mm stainless steel plate for the bin.

The machines are intended for use on terrain suitable for operation of tractor towed machinery. Should the machine require maintenance, or in the event of accident or breakdown, it should be parked on flat ground and appropriately restrained from rolling. Where the towing tractor is disconnected, the parking jack should be adjusted to hold the machine level.

Original Instructions

Produced February 2024

Copyright © 2024 by Giltrap Engineering Ltd.
Printed in New Zealand

All rights reserved. Reproduction or use, without express permission, of editorial or pictorial content, in any manner, is prohibited.

Table of Contents

Introduction	7
Delivery	7
Warranty	8
Serial Number Identification	9
General Safety	10
Pre-Service Guidelines & Settings	13
Initial Setup	14
HYDRAULIC REQUIREMENTS	14
COUPLING THE HYDRAULICS	14
POWER.....	14
Setting Door Height 5001 / 6601 / 8301 / 10001 / 12401	15
Setting Door Height 2501 / 3802	16
Clearing a Blockage	16
Basic Spreader Maintenance	17
ADJUSTING THE CONVEYOR BELT	17
GREASING THE MACHINE	18
GEARBOX OIL FILLING	18
Bulk Densities Rough Guide	21
Measuring Bulk Density of Product	22
Plumbing Diagram for all Except 3T / Orchard	24
Plumbing Diagram for 3T / Orchard	25
Fitting Rear Cross Conveyor to 3T / Orchard	26
Parts Book Section	27
TRANSFERS & LABELS.....	28
FARMSCAN COMPONENTS.....	29
APPLICATION RATE SENSORS	30
LOAD CELL MOUNTING COMPONENTS	32
FLOOR CONVEYOR COMPONENTS.....	34
SPINNER ASSEMBLY 2501 / 5001 / 6601 / 8301 / 10001 / 12401.....	37
SPINNER DISC OPTIONS	39
HYDRAULIC REAR DOOR ASSEMBLY.....	41
MANUAL REAR DOOR ASSEMBLY	42
AXLE ASSEMBLY	43
MODULAR AXLE ASSEMBLY	44
HUB ASSEMBLY – ADR.....	46
MONROC 60MM HUBS	48
MONROC 70MM HUBS	49
MONROC 80MM HUBS	50
MONROC 90MM HUBS	51
MONROC 100MM HUBS.....	52
DOOR CONTROL VALVE – HYHCV-3213	54
SPREADER CONTROL VALVE – HYHCV-3542 – TO FIT 3801 - 12401	55
SPREADER CONTROL VALVE – HYHCV-3656 – TO FIT 2501	56
GEARBOX DETAILS – RT200	57

GEARBOX DETAILS – RT300	58
GEARBOX DETAILS – RT400	59
GEARBOX DETAILS – RT400-2V	60
OPTIONAL ROLL-OVER COVER.....	61
OPTIONAL LIGHTS	61
BANDING ATTACHMENT – SINGLE SIDE	62
BANDING ATTACHMENT – DUAL SIDE.....	63
3T/ORCHARD CROSS CONVEYOR ATTACHMENT	64
3T/ORCHARD DUAL SIDE CROSS CONVEYOR ATTACHMENT.....	65
4T TO 15T CROSS CONVEYOR ATTACHMENT	66
Farmscan Section	67
SCREEN OVERVIEW	68
SETTING MAIN PARAMETERS.....	72
SPREAD RATE INDICATION ARROWS.....	75
HECTARE METER.....	76
PRODUCT DENSITY	77
ALTERING FLOW FACTOR.....	78
SPINNER CONTROL	79
SPINNER SPEED INDICATION ARROWS	80
SPINNER CALIBRATION	81
FLOW FACTOR CALIBRATION	83
JOB CREATION	86
USB DRIVES.....	87
OPERATION.....	88
CHECKING SOFTWARE VERSION	89
UPDATING SOFTWARE VERSION	90
EXPORTING SETTINGS TO USB	91
IMPORTING SETTINGS FROM USB	92
ZEROING BIN WEIGHT	93
USING GPS SPEED SOURCE	94
EXPORT GPS MAPPING TO USB	95
CLEARING GPS MAPPING.....	96
ENABLE PRIME MODE.....	97
SETTING SPINNER TURBO AND HALF SPEEDS	98
SECTION CONTROL	100
HEADLAND CONTROL.....	108
MONITOR LED STATUS LIGHTS – 7000 SERIES SCREEN ONLY	116
TROUBLESHOOTING	118
Orchard-MD Operation	121
SPREAD METHOD SELECTION	121
REAR SPINNER OPERATION.....	121
FRONT CROSS CONVEYOR OPERATION.....	122
Orchard-MD Maintenance.....	126
ADJUST FLOOR BELT TENSION	126
ADJUST CROSS CONVEYOR BELT TENSION.....	126
Orchard-MD Parts Manual	127
CHAIN ASSEMBLY	128
CHAIN BED – DRIVE END	129
CHAIN BED – IDLER END	130
SPINNER ASSEMBLY	131
DOOR – REAR	133
DOOR – FRONT	134
CROSS CONVEYOR.....	135
BIN – REAR.....	136
BIN – FRONT	137

EU Declaration of Conformity 138

Introduction

Thank you for purchasing a Giltrap product. Giltrap Engineering Ltd has enjoyed a long-standing success with their machinery. We would like you to enjoy the benefits of owning a Giltrap too. By following the guidelines laid out in this book, you will ensure trouble free, low maintenance operating for years.

Giltrap Engineering Ltd is a progressive company which continually strives to satisfy your needs, so we welcome any feedback which you can provide to help us improve our products and services and to ensure that they perform to your expectations. Any constructive comments about this operator's manual are also welcome.

Your machine has been designed to perform its task efficiently and with a minimum of maintenance. This handbook provides safety guidelines, instructions, maintenance requirements and parts listings. We recommend that you read the entire handbook, before operating the machine as this will enable you to take full advantage of your new machine's considerable potential.

Delivery

Before you begin to use your machine, please check it to make sure there is no delivery damage. If damage is evident, contact the dealer who supplied the machine so that they can make the appropriate claims.

If you have any other queries, please contact your dealer or Giltrap Engineering Ltd (0800 80 GILTRAP).

Please fill in the details below for future reference.

Model:

Serial No:

Delivery Date:

Dealer:

Warranty

The goods specified in the Price List as designed and supplied by Giltrap Engineering Ltd are warranted against faulty workmanship and defective materials for a period of 24 months from the date of purchase. In addition to the primary 24 month warranty for Giltrap products, there is a further 12 month structural warranty for the goods, against faulty workmanship and/or defective materials for structural items only. The structural warranty does not apply to electronics or component parts.

Such warranty is subject to the following conditions:

1. This warranty covers the repair or replacement of parts or machinery sold by the manufacturer and damaged as a result of the faulty workmanship or materials in such parts or machinery. It does not extend to any other loss or damage including consequential loss or damage or loss to other property or persons.
2. Without limiting the generality of paragraph 1 above, this warranty does not cover the following:
 - (a) Travel expenses.
 - (b) Damage caused by accident, misuse or abuse.
 - (c) Damage to any goods which have been altered or modified by someone other than the manufacturer or its authorised agent.
 - (d) Damage or loss to the goods due to their unsuitability for any particular use or for using with any particular tractor except where such use or tractor had been specifically approved by the manufacturer.
 - (e) Damage or loss where the fitting and installation of the goods were not carried out by the manufacturer or its authorised dealer.
3. Procedure for recovery under warranty.

No loss or damage will be covered by this warranty unless the loss or damage is reported immediately to the dealer (who will contact the distributor who will advise whether it is covered by the warranty and undertake the necessary action).

No warranty repair work is to be undertaken prior to an order number being obtained.

This warranty shall be interpreted according to the laws of New Zealand and the parties agree to submit to the jurisdiction of the Courts of New Zealand.

Serial Number Identification

Before ordering any parts, check the serial number of the machine and include this information with all orders.



General Safety

For the safety of others and yourself, please read and follow the precautions in this operator's manual. Pay particular attention to the following safety aspects of operating machinery.

Do not ride on or allow passengers on the machine.



Always use a recognised hitch pin with a safety clip to hook trailed implements on behind the tractor.

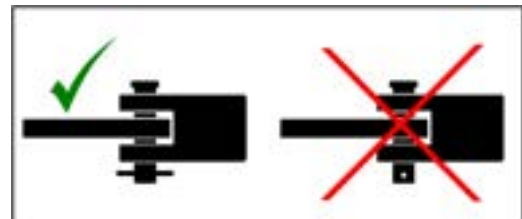

Always ensure when using a quick hitch that the locking tab has come out and is in the locked position before moving.

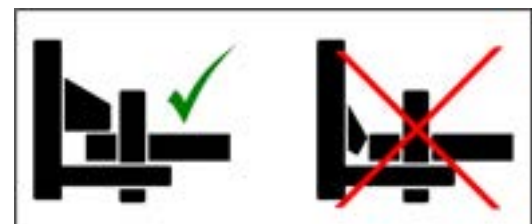

Do Not operate tractor – trailer combination outside of manufacturers recommended drawbar loading.

Carry a suitable fire extinguisher.

A fire can ignite under certain conditions, so please take the following precautions:

After running your machine for a short time, check for defective bearings. A faulty bearing can become very hot, eventually discolouring, requiring immediate replacement.

Do not allow combustible material to accumulate inside guards or around rollers and other moving parts.

If your machine becomes blocked, stop immediately and remove the obstruction.

Be careful when operating in hot or dry conditions or on extreme fire risk days.



Never operate your machine without the safety guards in place.



All chains should be properly adjusted and replaced when necessary.

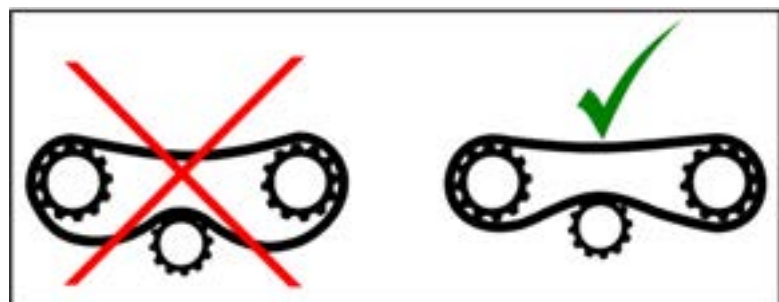

Release all hydraulic pressure from implements before commencing service work. Never look for suspected oil leaks with your hands or body - use a piece of cardboard instead.

Any fluid that penetrates the skin will have to be removed immediately by a medical expert. Seek specialist advice on this type of injury.



Never attempt to unblock equipment while it is still operating.

Always disengage power take-off, hydraulics and shut down engine before removing materials, checking or servicing.

Failure to follow these precautions is likely to result in serious injury.

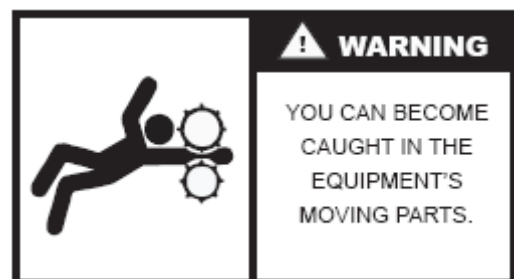

Wear proper protective clothing. Loose attire can easily be snagged by rotating machinery resulting in serious injury or death.



Pre-Service Guidelines & Settings

Prior to delivering your machine, your dealer should have completed a pre-delivery check. It is required to check the following points before using the machine for the first time.

- CHECK ALL WHEEL NUTS ARE SUFFICIENTLY TIGHT.

Wheel Nut Recommended Torque Settings

M18 Stud	200 ft/lbs or 270Nm
M20 Stud	280 ft/lbs or 380Nm
M22 Stud	330 ft/lbs or 450Nm

- CHECK ALL TYRE PRESSURES ARE CORRECT.

Recommended Tyre Pressures

11.5/80-15.3	58psi	4.0 bar
400/60-15.5	50psi	3.5 bar
15.0/70-18	45psi	3.1 bar
400/55-22.5	46psi	3.2 bar
500/45-22.5	35psi	2.4 bar
500/60-22.5	35psi	2.4 bar
560/45R22.5	58psi	4.0 bar
560/60R22.5	58psi	4.0 bar
650/55R26.5	58psi	4.0 bar

- CHECK ALL AXLE MOUNTING BOLTS AND NUTS ARE SUFFICIENTLY TIGHT.

Axle Mounting Bolt Recommended Torque Settings

M16 - 180 ft/lbs or 245Nm
M20 - 355 ft/lbs or 480Nm

- THE CONVEYOR BELT should be checked for alignment and tension, and adjusted if necessary to ensure it is tracking correctly. See page 15 for information on conveyer belt adjustment.
- THERE ARE SEVERAL GREASE POINTS on all machines. Check the yellow label on the side of your machine to see how many grease points there are. You should fully grease everything before running it for the first time. See page 16 for lubrication details.
- CHECK AND RETIGHTEN WHEEL NUTS AFTER:
 - First use
 - First laden journey
 - The first 50 hours of use and every 50 hours thereafter

Initial Setup

Hydraulic Requirements

The spreader is fitted as standard with two 32cc hydraulic motors running in parallel, requiring an oil flow of 60 l/min @ 2500 psi.

For tractors with flows below this amount, it is possible to plumb the motors in a series arrangement. In this setup, 35 l/min will suffice.

Two spinner motors running in parallel. This option gives the spinners more torque and runs the spinners at lower pressures but the machine would then only operate with a minimum of 60 l/min flow. See the diagram below to change between parallel and series.

If the hydraulic flow from the tractor is adjustable, reduce the flow too slightly above the point where the spinners begin to slow.

Coupling the Hydraulics

The pressure hose must be coupled to a high pressure outlet point on the tractors external system.

The return hose can be coupled into the same double acting bank using the quick release coupling supplied but can give better performance if plumbed directly back to tank via a large $\frac{3}{4}$ " or 1" dump connection.

Giltrap Engineering recommends connection to a large $\frac{3}{4}$ " or 1" dump connection where available.

With the tractor at idle, engage the hydraulics. For most common setups, the right hand spinner should rotate clockwise and the left hand spinner run anticlockwise.

Nothing should operate when the hydraulics are reversed.

Note: all machines have a reversible spinner circuit fitted as standard so the spinner direction can be reversed if required for bulky material such as mulch or compost.

Power

12V supply is required **directly from the tractor's battery** through the supplied fused loom.

Setting Door Height 5001 / 6601 / 8301 / 10001 / 12401

The door is controlled by a separate hydraulic circuit from the floor and spinners; it is recommended that this circuit is connected to a tractor spool valve that has been adjusted to provide low flow to reduce speed of movement.



Remove shaft lock pin, and move collar to control height that door will open to.

IMPORTANT – It is vital that the machine is operated with the door opened fully against collar.

The 5001 – 8301 have 11 positions including fully closed.

Preset the opening as per the Spreading Rate Guide chart. A sticker of this chart has been placed on the machine; there is also a copy without annotations in this manual.

The door opening is measured from the top of the belt to the bottom of the door. Enter this value into the controller.

DO NOT measure from the top of the cleats on the belt.

Note that the 6601 and 8301 have an optional 2 speed gearbox available to spread high rates when necessary.

Setting Door Height 2501 / 3802

The 2501 – 3802 models have 25 positions including fully closed.

Preset the opening as per the Spreading Rate Guide chart. A sticker of this chart has been placed on the machine; there is also a copy without annotations in this manual.

The door opening is measured from the top of the belt to the bottom of the door. Enter this value into the controller.

DO NOT measure from the top of the cleats on the belt.



Clearing a Blockage

Should the machine experience a blockage of the door or the spinner assembly, follow the operating method below:

1. Stop the machine and turn off the tractor
2. Inspect the machine for the location of the blockage.
3. If the spinners are blocked, clear the material with suitable tools. Be careful not to damage hydraulic hoses or electrical cables.
4. If the door is blocked, it may be advantageous to open the door fully. With the machine off, adjust the height stop block to allow maximum height. Start the tractor and lift the door fully up. **Turn off the tractor.** Clear the blockage using a suitable tool from the rear of the machine. If the machine is equipped with a fold down ladder, this may be used to reach the blockage from the side of the machine.

Basic Spreader Maintenance

Adjusting the Conveyor Belt

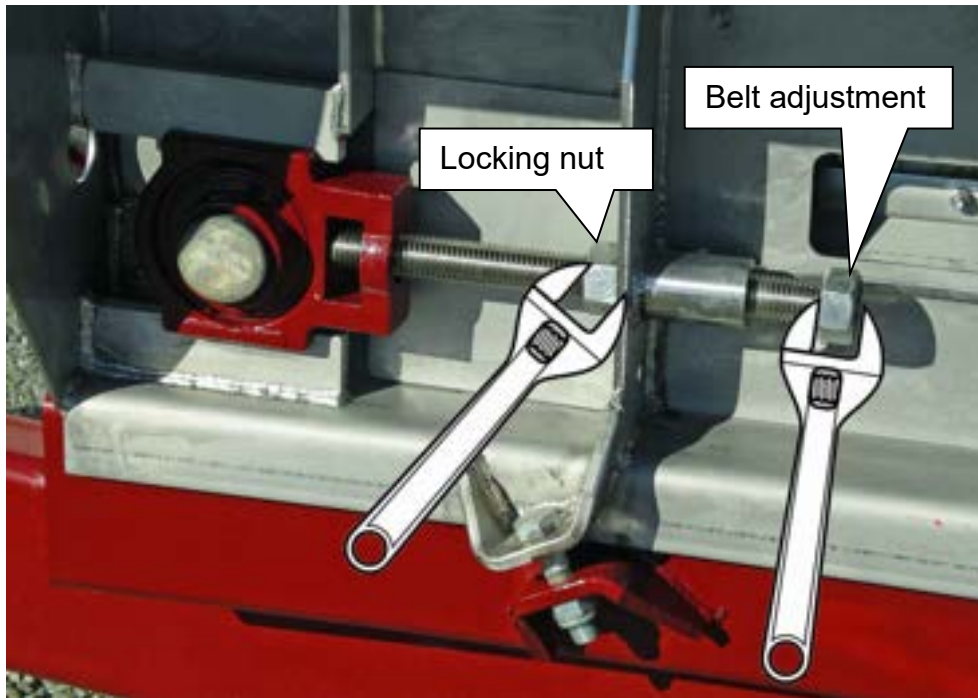

- If the drive roller slips (belt won't turn) hold a spanner on the locking nut and tighten (turn clockwise) the belt adjustment screw (1 full turn with spanner on both sides of the machine) and retry.
- If the belt moves across to one side, hold a spanner on the locking nut on the side that the belt moved to and tighten (turn clockwise) the belt adjustment screw $\frac{1}{4}$ turn per time then let it run for 5 minutes. **The belt will move away from the side that you tighten.**
- **Do not touch the rear adjuster nuts. These are for setting the rear roller square to the bin and should not need to be adjusted.**



Greasing the Machine

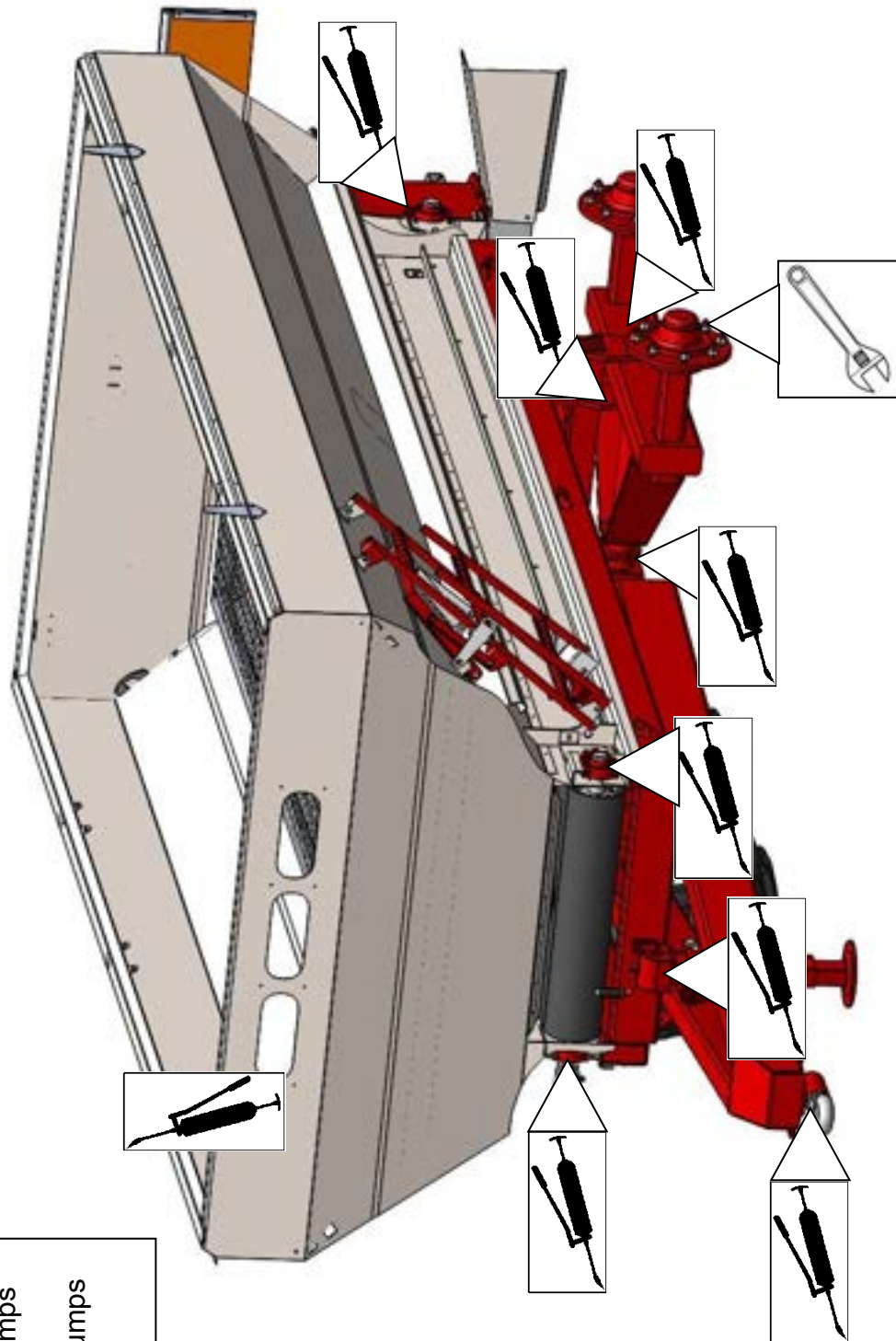

Axle Bushes (x6) – 4 pumps every second day
Wheel Hubs (x4) – Repack bearings 6 monthly
Conveyor Bearings (x4) – 1 pump every 2nd day
Jack Stand (x1) – 4 pumps weekly
Towing Eye (x1) – 4 pumps weekly

Gearbox Oil Filling

RT200 (2.3L Fill Capacity) – Fitted to 2501, Orchard, and 5001

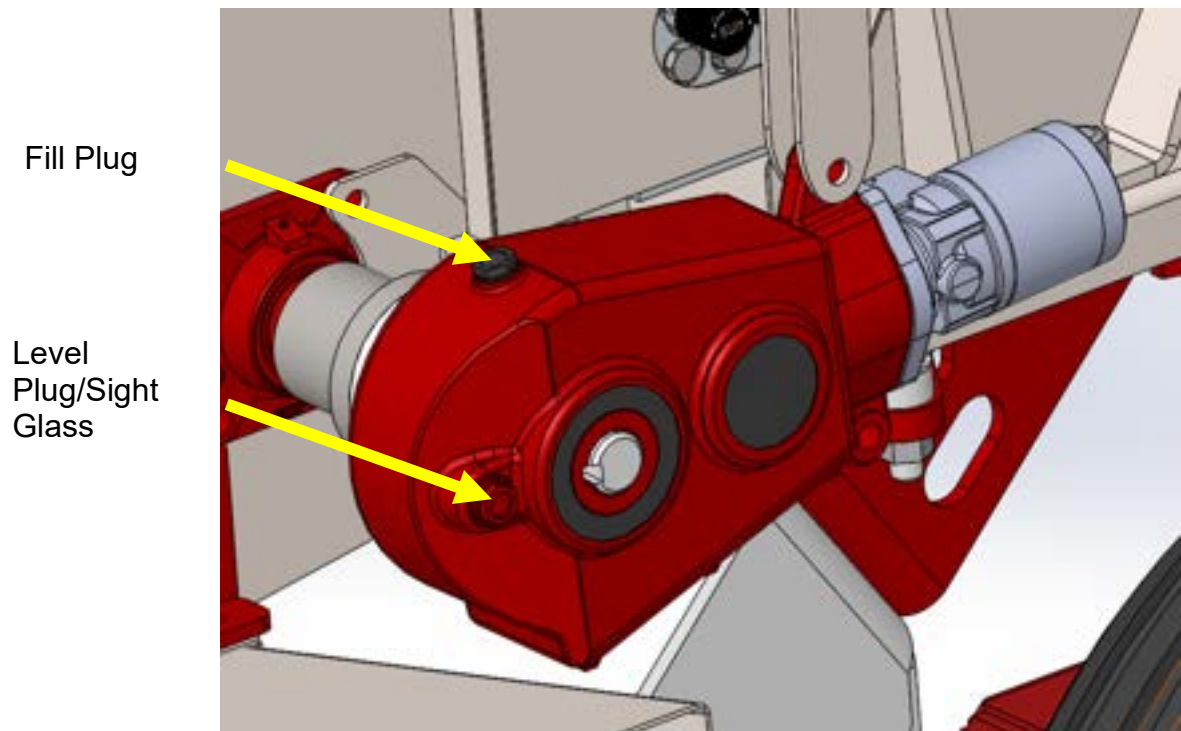

RT300 (3.8L Fill Capacity) – Fitted to 6601

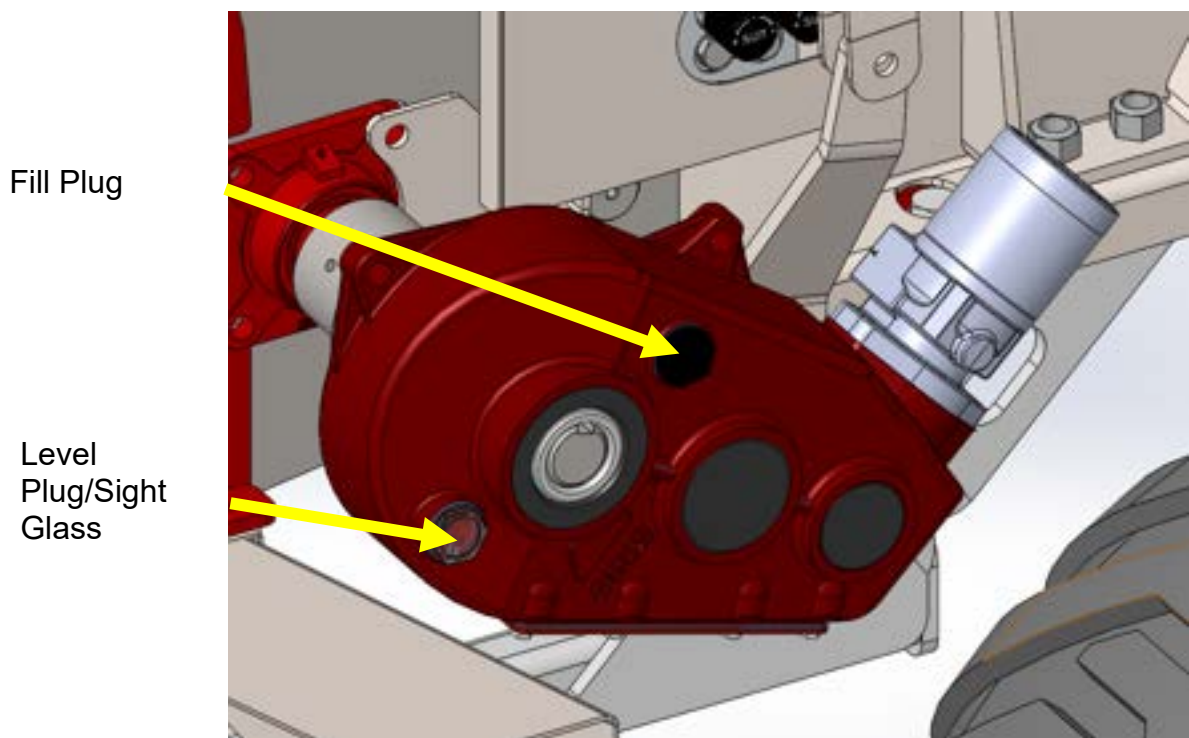

When filling the RT300 Gearbox, the sight glass must be completely submerged in oil.

RT400 (4.3L Fill Capacity) – Fitted to 8301, 10001, and 12401

Fill Plug

Level
Plug/Sight
Glass

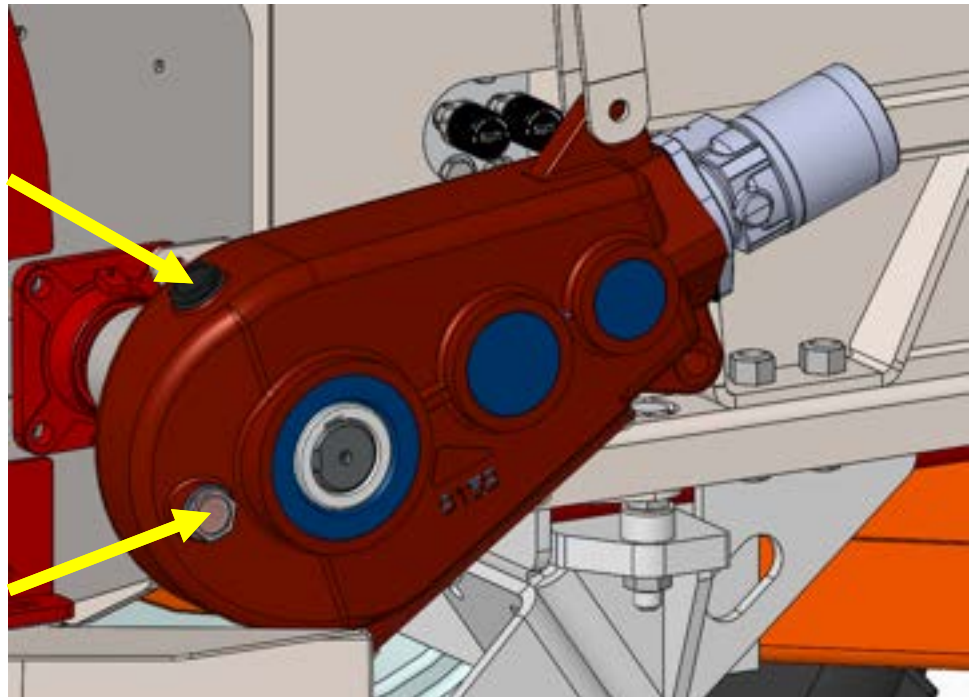

RT400-2V (5.0L Fill Capacity) – Option on 8301, 10001, and 12401

Fill Plug

Level
Plug/Sight
Glass

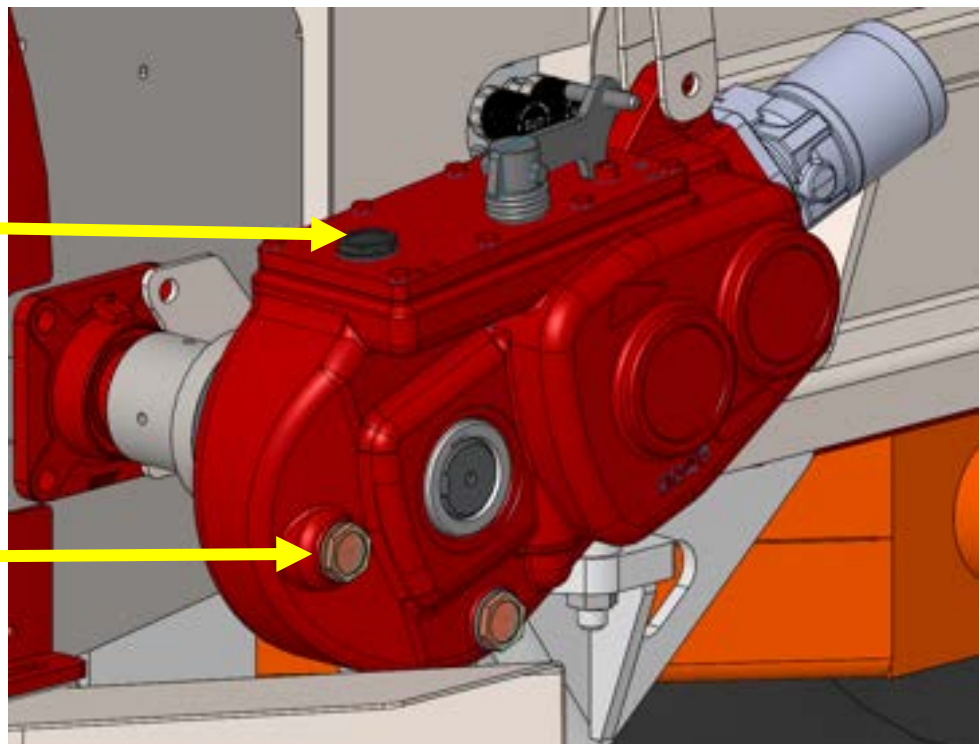

Bulk Densities Rough Guide

Please note these densities are a guide only and for accurate spreading each batch of product should be measured with the provided scales and measuring cup as per the instructions on the following page

PRODUCT	kg / liter
CAN	1.1
DAP	1.1
Dolomite	1.4
Durasul Sulphur	1.35
Granmag	1.1
Lime	1.55
MAP	1.1
Meat and Bone Meal	0.8
Muriate of Potash	1.2
Nitrophoska 12-10-10	1.1
Nitrophoska Blue	1.1
Reactive Rock - Sechura	1.5
Salt	1.2
Serpentine Super	1.25
Sulphate of Ammonia	1.0
Sulphate of Potash	1.1
Sulphur (raw)	1.35
Superphosphate (granular)	1.2
Superphosphate (powder)	1.1
Triple Super	1.15
Urea	0.85

Measuring Bulk Density of Product

Follow the instructions below for the most accurate way of measuring the bulk density of products, this is crucial in order to achieve accurate rates of spreading.



Turn scale on by pressing and holding button marked



Ensure units are in grams (displayed g), if needed change by pressing the unit button



Place empty cup on scale and then zero scale by pressing button marked



Fill the cup with product, ensuring it is level with the top



Weigh the product

Divide the weight in grams by 1000 to get the product density.

For example if the cup weighed 1644 grams the density would = 1.64KG/L

A cup weighing 900 grams would = 0.90KG/L

Take 3 samples of product and average them for best results

Enter density into control system

Spreading Rate Guide Chart

GILTRAP SPREADING RATE GUIDE CHART

How to use the chart

- 1) Select your spreading application rate in kg/hectare.
- 2) Move up until you hit your average spreading speed line. This is your door height setting (mm).
- 3) Set door to recommended height.
- 4) Enter door height into controller.

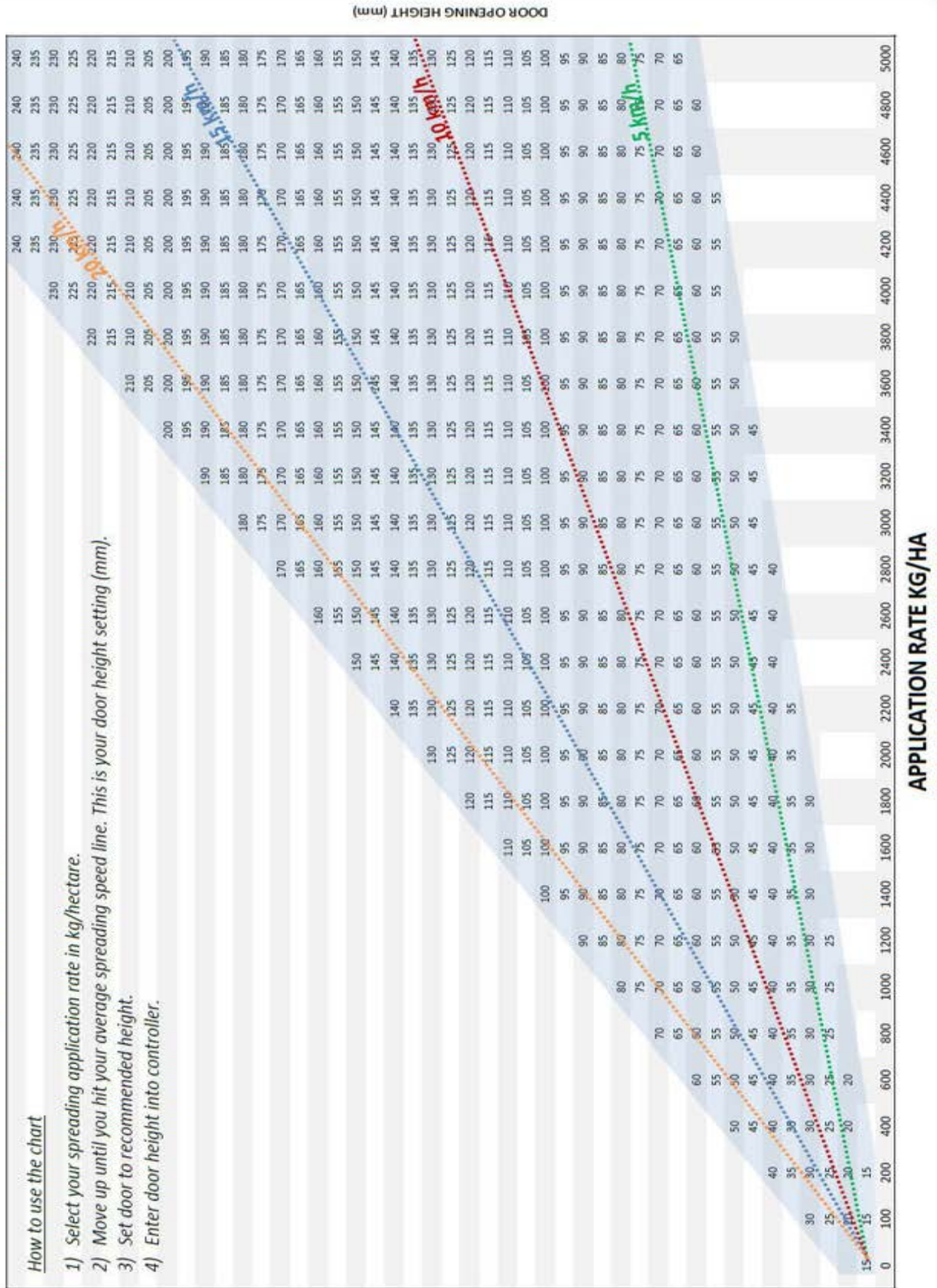

Plumbing Diagram for all Except 3T / Orchard

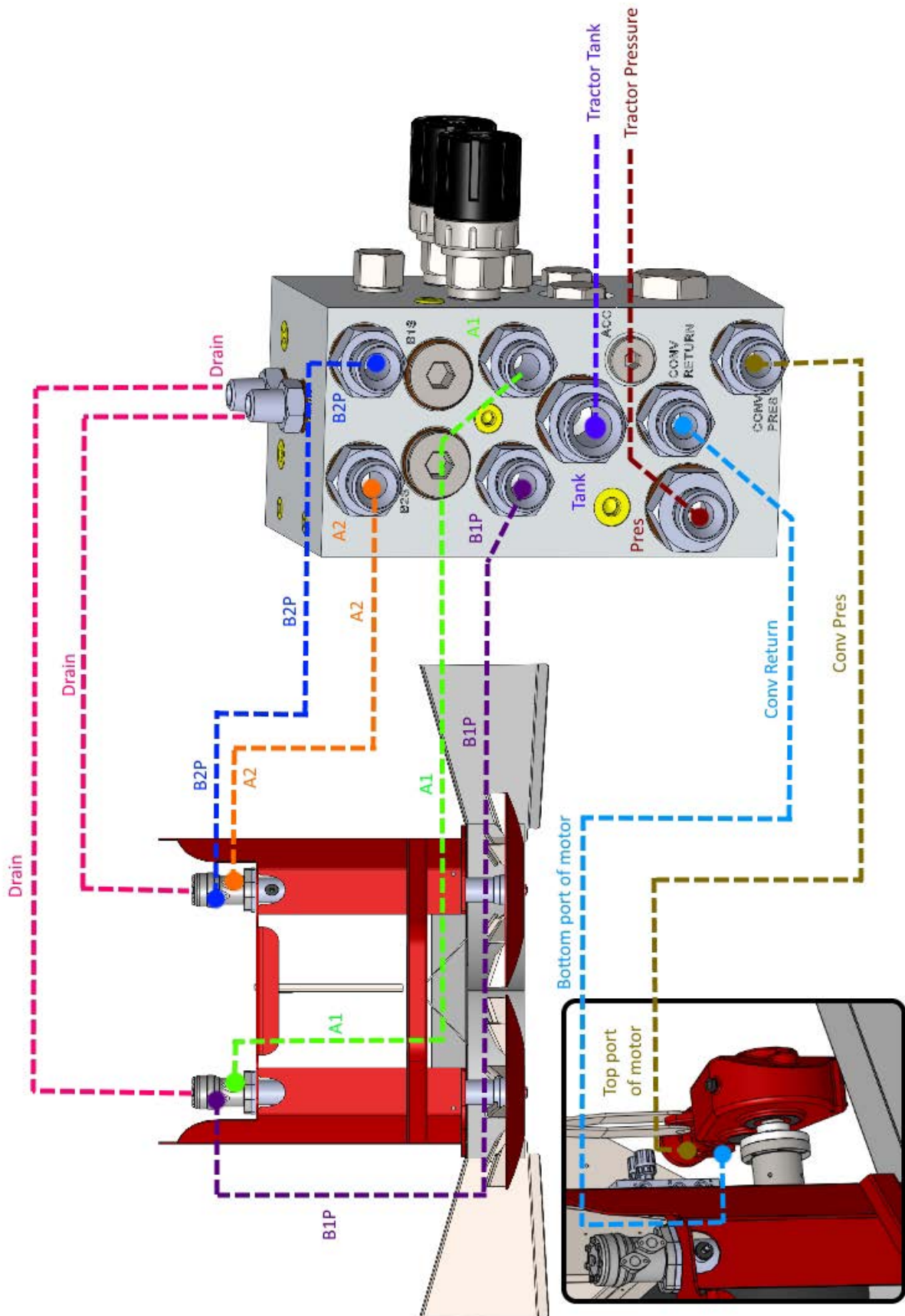

Plumbing Diagram for 3T / Orchard

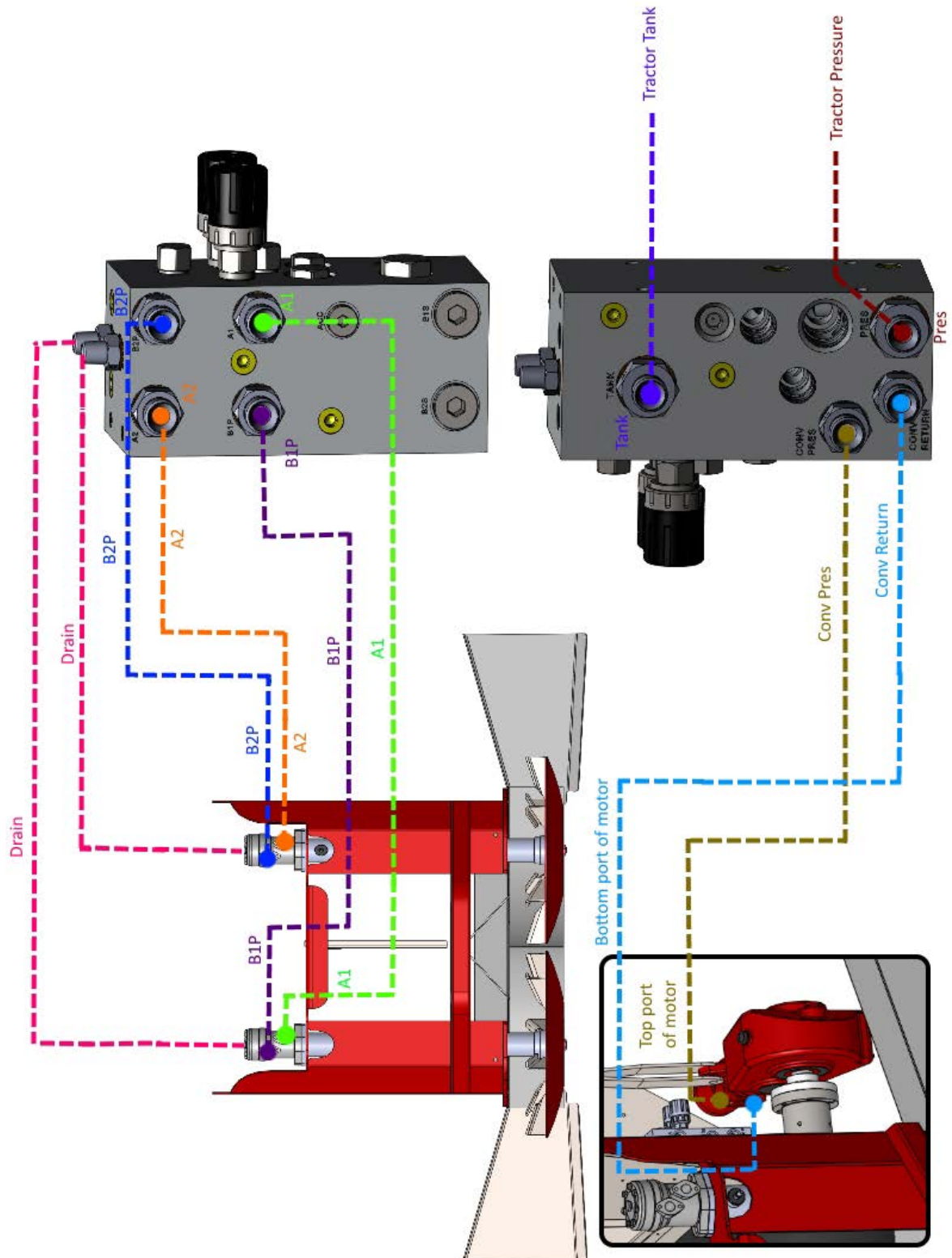

Fitting Rear Cross Conveyor to 3T / Orchard

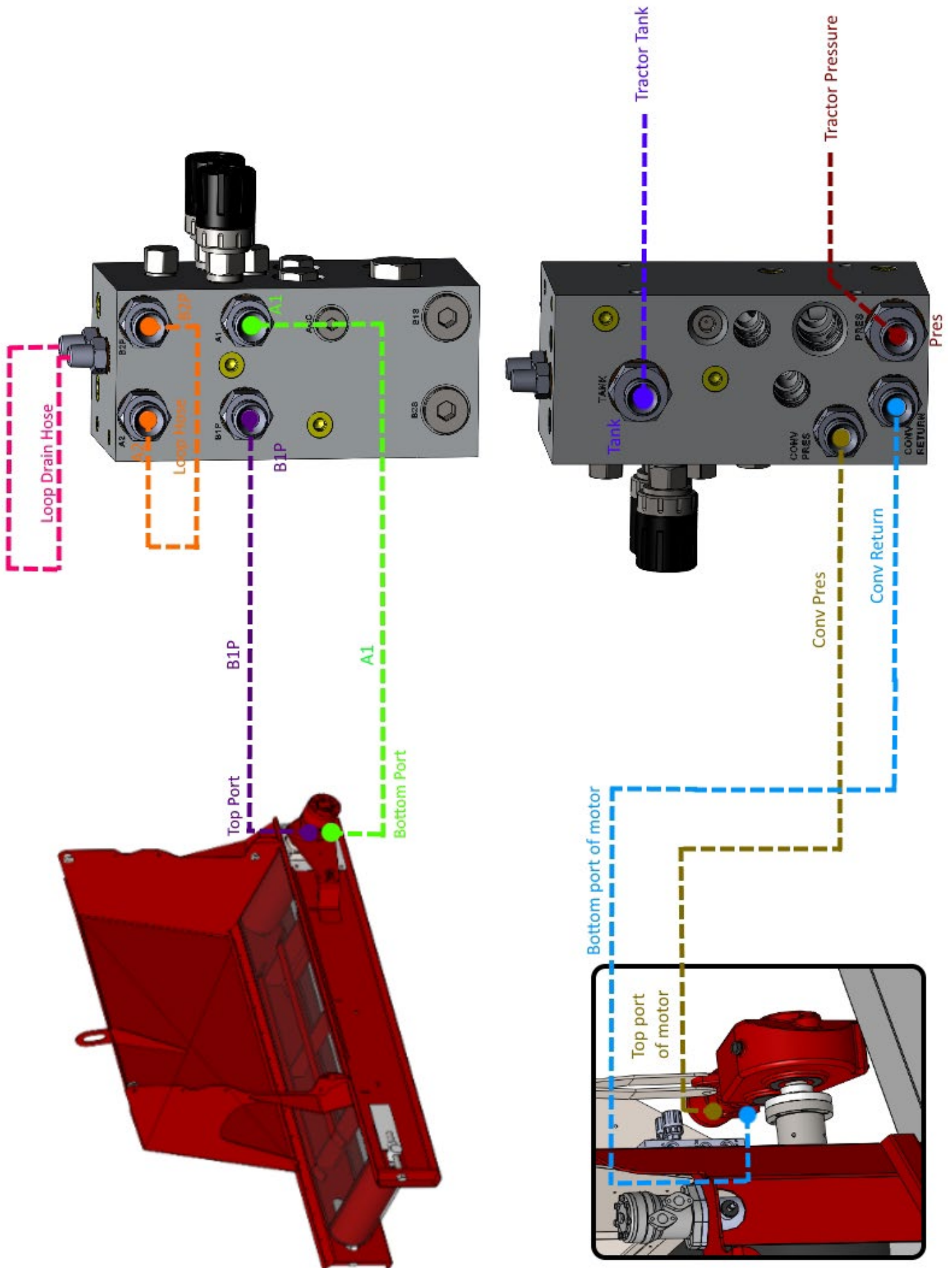

Parts Book Section

Table of Contents

TRANSFERS & LABELS	28
FARMSCAN COMPONENTS.....	29
APPLICATION RATE SENSORS	30
LOAD CELL MOUNTING COMPONENTS	32
FLOOR CONVEYOR COMPONENTS.....	34
SPINNER ASSEMBLY 2501 / 5001 / 6601 / 8301 / 10001 / 12401.....	37
HYDRAULIC REAR DOOR ASSEMBLY.....	39
MANUAL REAR DOOR ASSEMBLY	42
AXLE ASSEMBLY	43
HUB ASSEMBLY – ADR.....	44
MONROC 60MM HUBS	48
MONROC 70MM HUBS	49
MONROC 80MM HUBS	50
MONROC 90MM HUBS	51
MONROC 100MM HUBS.....	52
DOOR CONTROL VALVE – HYHCV-3213	54
SPREADER CONTROL VALVE – HYHCV-3542 – To FIT 3801 - 12401	55
SPREADER CONTROL VALVE – HYHCV-3656 – To FIT 2501.....	56
GEARBOX DETAILS – RT200	57
GEARBOX DETAILS – RT300	58
GEARBOX DETAILS – RT400	59
GEARBOX DETAILS – RT400-2V	60
OPTIONAL ROLL-OVER COVER.....	61
OPTIONAL LIGHTS	61
BANDING ATTACHMENT – SINGLE SIDE	62
BANDING ATTACHMENT – DUAL SIDE.....	63
3T/ORCHARD CROSS CONVEYOR ATTACHMENT	64
3T/ORCHARD DUAL SIDE CROSS CONVEYOR ATTACHMENT.....	65
4T TO 15T CROSS CONVEYOR ATTACHMENT	66

Transfers & Labels

Part Number	Description	Quantity
995-1025	Label 'CAUTION! Ensure Hydraulic...'	1
995-1221	Label 'Stand well clear...'	2
995-1223	Label 'This machine has...'	1
995-1228	Label 'Ensure jack is in...'	1
995-1240	Label 'DANGER'	1
995-1245	Label Grease Gun	6
995-1550	Giltrap Orchard	2
995-1553	2501	2
995-1154	3802	2
995-1556	5001	2
995-1558	6601	2
995-1560	8301	2
995-1565	"G" Logo	2

Farmscan Components

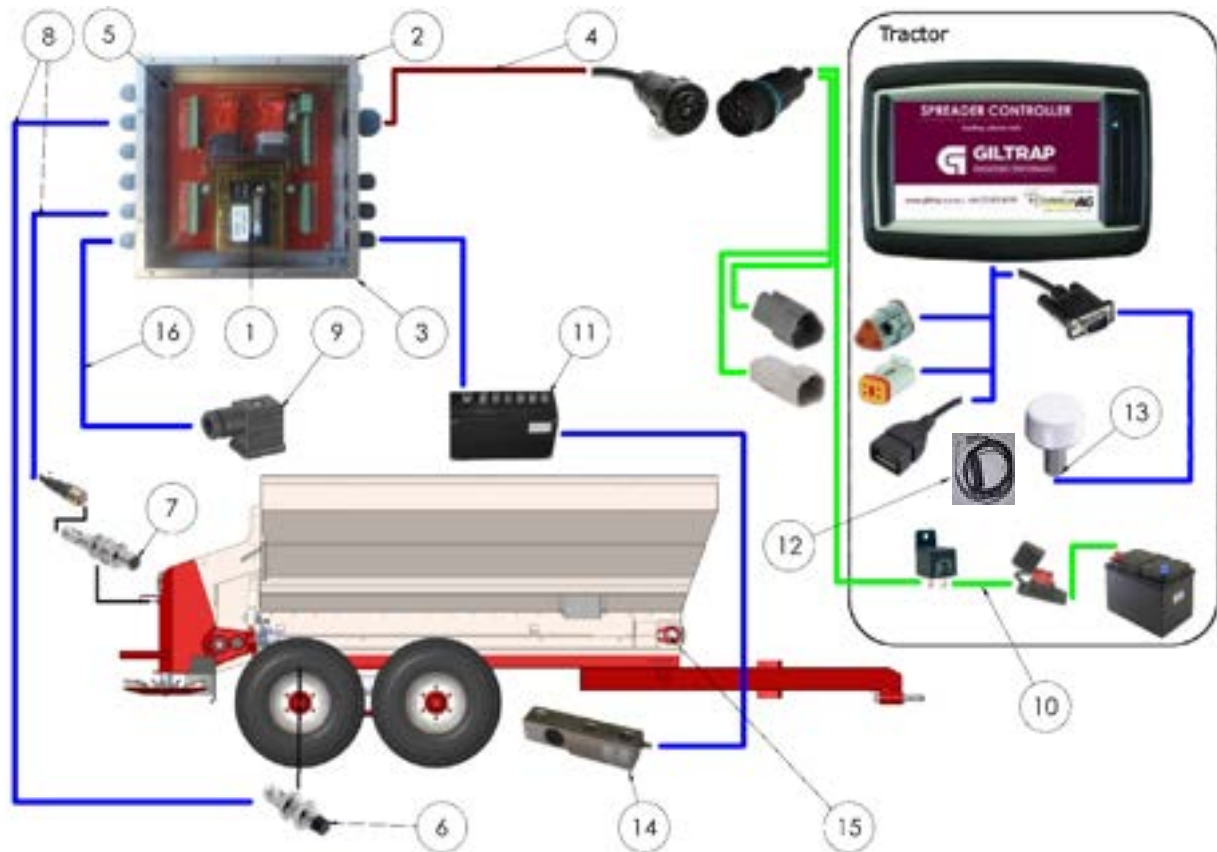

Item	Part Number	Description	Quantity 2501-5001	Quantity 6601+
1	11640	Farmscan Spreader Unipod	1	1
2	11645	Control Unit - Enclosure	1	1
3	11646	Control Unit - Complete	1	1
4	11647	Implement Loom – Screw in type (or see below)	1	1
	11647-Lev	Implement Loom – Lever lock type	1	1
5	11650	Junction Board	1	1
6	11652	Wheel Speed Sensor	1	1
7	11654	Spinner Speed Sensor - E2A-S12KS04-M1-C1	2	2
8	11657	Sensor Cable – Straight Plug -10M	2	2
9	11695	DIN Coil Plug	3	3
10	11660	Tractor Loom – Screw in type (or see below)	1	1
	11660-Lev	Tractor Loom – Lever lock type	1	1
11	11680	Load Cell Junction Box	1	1
12	11682	Run / Hold Switching cable only (optional)	1	1
	13691	Run / Hold Switch & Cable assembly (optional)	1	1
13	11685	GPS Antenna – Optional	1	1
14	ES-WLY00003P-S-S	Load Cell – Optional	4	6
15	14179	SmartAg Application Rate Sensor Kit	1*	1*
16	#ES-2C	Dual Core Wire For Coil	Measure to order	Measure to order

*Check Application Rate Sensor info on next page before ordering

Application Rate Sensors

If your machine is fitted with an older encoder (Black housing), the complete encoder and mount kit (Part # 14179) is required to fit the current encoder (Silver housing).



SmartAg Rate Sensor

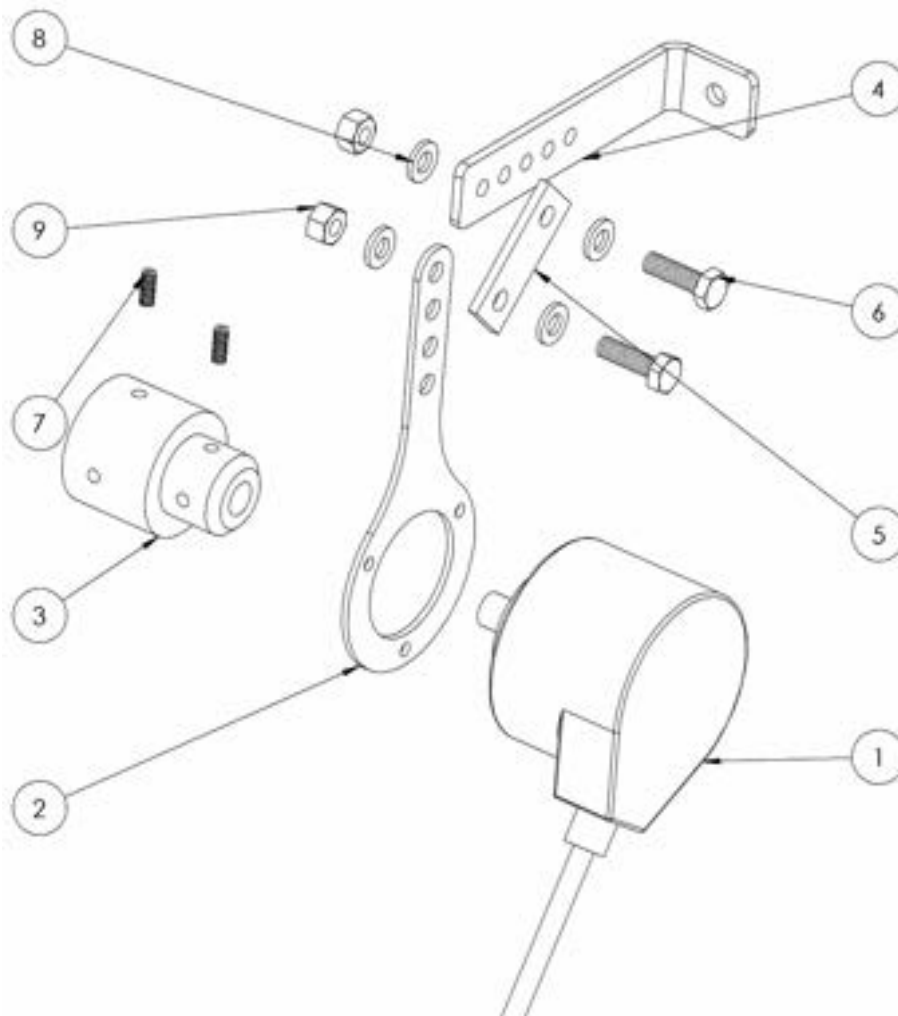

Item	Part Number	Description	Quantity
1	S/A RATE SENSOR	SmartAg Application Rate Sensor	1
2	13655	Torque Mount Plate EWWN	1
3	13823	SmartAg Rate Sensor Bush	1
4	11869	Fert Mount Plate for Encoder	1
5	13824	Rate Sensor Flex Joint - Fert Spreader	1
6	B6X20-SS	Bolt, M6X20 Stainless Steel	2
7	GSC10-32UNF	Grub Screw, #10-32UNF	2
8	WA6-SS	Washer, M6 Stainless Steel	4
9	N6-SS	Nut, M6 Stainless Steel	2

Load Cell Mounting Components

- Applies to post 2019 machines with Single load cell-capable chassis

ITEM NO.	PART NUMBER	Rev'd/ korr	DESCRIPTION
1	ES-WLY00003P	A1	SHEAR BEAM
2	Spherical washer A-3W20-40	A1	Spherical washer
3	WA-21X40X35S	A1	Ekal Washer
4	M20-S-S	A1	M20 HEX Nut
5	13031 Ball	A1	ball mount ball
6	MM20-S-S	A1	Nylock Nut M20-S-S
7	820X90	A1	Load cell spacer
8	13498 washer	A1	LC Nut locker
9	13695 Locker	A1	LC Nut locker
10	WA-20NORDL	A1	Nord Lock washer M20

Note: orientation of load cell (inverted)

Shorten 396-1025 bolt stainless steel fasteners throughout

Standard Method

1. Tighten these nuts up to 450Nm torque

2. Tighten bolt head tight against this nut (retained by nut-locking assembly) up to 450Nm torque.

3. Hold bolt head from rotating. Tighten this nut up to 200Nm torque.

Two-part Nord-lock washer assembly

(in recess)

Chassis mount

Nylock nut

Rt spherical washer with din half facing downward

GILTRAP
ENGINEERED PERFORMANCE

THE INFORMATION CONTAINED IN THIS DRAWING IS THE PROPERTY OF GILTRAP ENGINEERING LTD. THE APPLICATION OF THIS DRAWING WITHOUT THE AUTHORIZATION OF GILTRAP ENGINEERING IS PROHIBITED.

TOLERANCE TABLE	AS PER PARTS	REVISION	A1	SHEET	1 of 2
DATE	17/03/2023	SCALE	1:2	SHEET SIZE	A3
DESIGNED BY	13028	CHECKED		DESCRIPTION	load cell Assy
DRAWN BY		SCALE		PART NUMBER	13028 Load cell Assy

See next page for earlier method

ITEM NO.	PART NUMBER	Revision	DESCRIPTION
1	ES.WLY00003P-S-S	A1	SHEAR BEAM
2	Spherical washer A-SW20-40	A1	Spherical washer
3	WA.21X40X3SS	A1	Flat Washer
4	N20-S-S	A1	M20 HEX Nut
5	13031 Bolt	A1	cell mount bolt
6	NN20-S-S	A1	Nylock Nut M20-S-S
7	B20x90SS	A1	
8	13498 washer	A1	Load cell spacer
9	13695 Locker	A1	LC Nut locker
10	WA.20NCRDL	A1	Nord Lock washer M20

Note orientation of load cell (inverted)

Shorten 556-1028 bolt

Stainless steel fasteners throughout

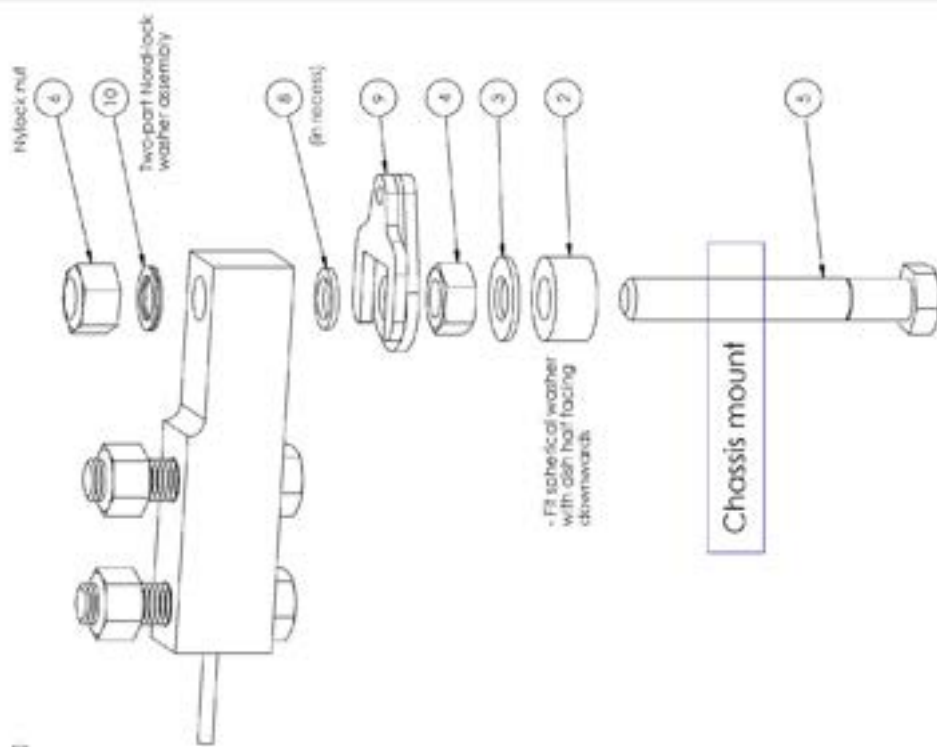

Early Method

Note: One some spreaders the bolt head may interfere with the bin during assembly. In this case the bolt should be inserted from below and the nut fitted to the top. The tightening process is then as below:

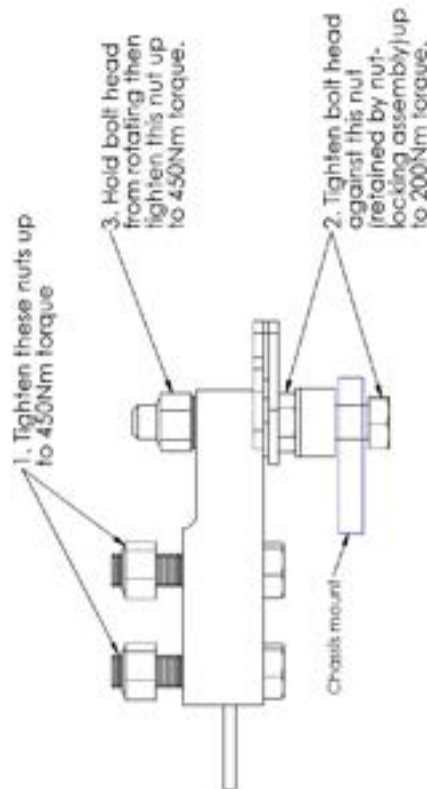

GILTRAP
ENGINEERED PERFORMANCE

THE INFORMATION CONTAINED IN THIS DRAWING IS THE PROPERTY OF GILTRAP ENGINEERING LTD. ANY REPRODUCTION IN PART OR AS A WHOLE WITHOUT THE WRITTEN PERMISSION OF GILTRAP ENGINEERING IS PROHIBITED.

MATERIAL	AS PER PARTS	REVISION	A1	SHEET	2 of 2
CAD GENERATED DRAWING	DO NOT MANUALLY UPDATE	DRAWN		DESCRIPTION	LOAD CELLassy
DATE	17/03/2023	CHECKED		PART NUMBER	13028 Load cell assy
		SCALE	1:2	SHEET SIZE	A3

Floor Conveyor Components

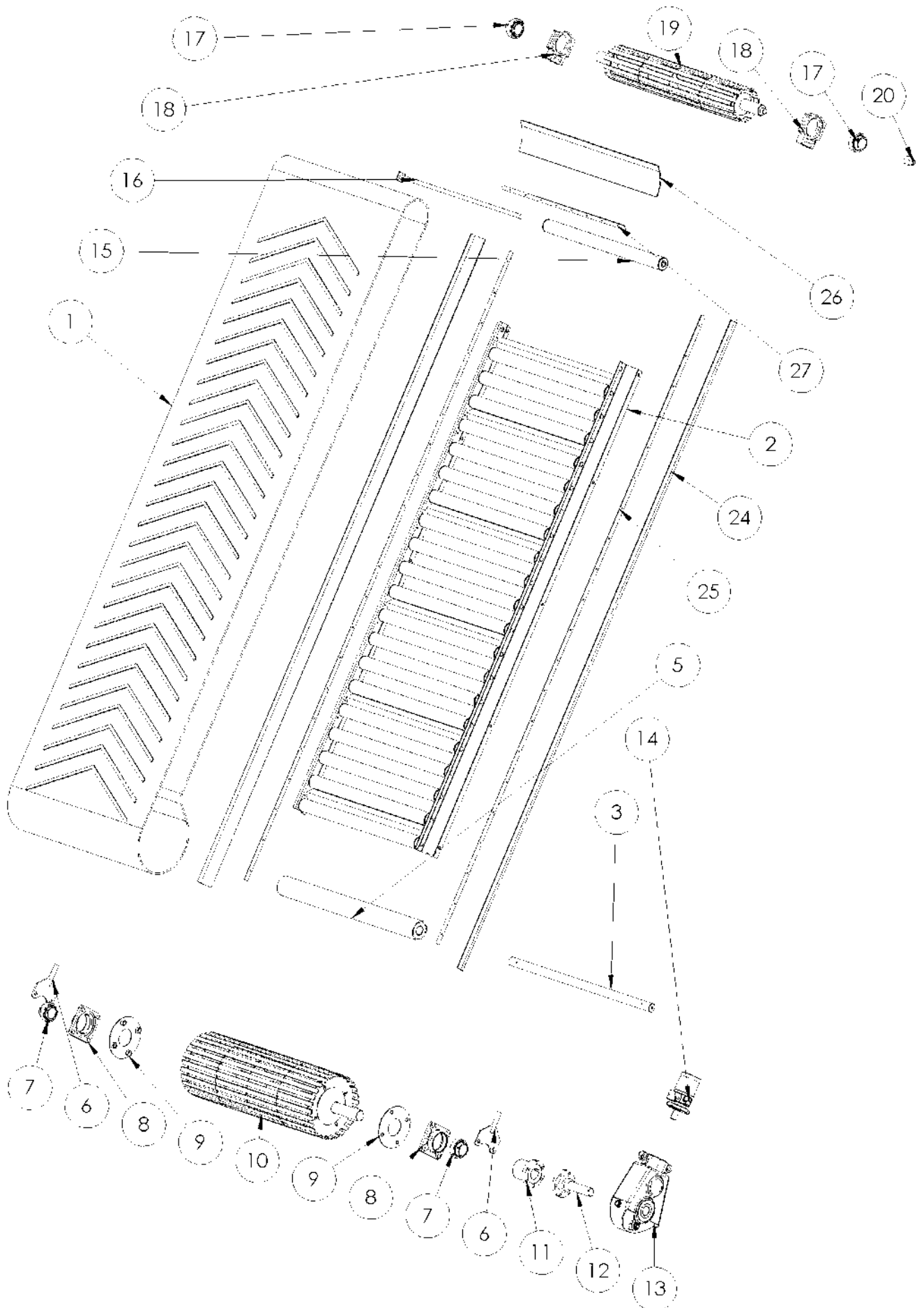

Giltrap Fertiliser Spreader

Item	Part Number	Description	Quantity					
			2501	3801	3802	5001	6601	8301
1	501-9155	Conveyor belt with cleats 6.15 x 0.85m	1					
1	501-9162	Conveyor belt with cleats 5.35 x 0.85m		1				
1	501-9148	Conveyor belt with cleats 6.77 x 0.85m			1	1		
1	501-9169	Conveyor belt with cleats 7.77 x 0.85m					1	
1	501-9176	Conveyor belt with cleats 9.57 x 0.85m						1
2	135-2510	Conveyor bed frame Mini	1					
2	135-2520	Conveyor bed frame 4T		1				
2	135-2500	Conveyor bed frame 6T			1	1		
2	135-2530	Conveyor bed frame 8T					1	
2	135-2540	Conveyor bed frame 10T						1
3	135-4188	Pinch roller shaft	1	1	1	1	1	1
4	GRN8-ST	Grease nipple	2	2	2	2	2	2
5	135-4195	Pinch roller (complete with bushes)	1	1	1	1	1	1
6	13680	Bearing adjuster	2					
6	13681	Bearing adjuster		2	2	2	2	2
7	BRGYAR210-2F	Bearing	2	2	2	2	2	2
8	HSGF310	Bearing housing	2	2	2	2	2	2
9		Bearing nut retainer	2	2	2	2	2	2
10	135-4254	Drive roller		1	1	1	1	
10	135-4263	Driver roller – Ceramic Coated						1
10	135-4255	Drive roller - Mini	1					
11	135-4128	Female shaft coupling – 50mm	1	1	1	1	1	1
12	135-4149	Male shaft coupling – 40mm	1	1	1	1		
12	135-4142	Male shaft coupling – 45mm					1	
12	135-4135	Male shaft coupling – 55mm						1
13	GBRT200-40	Gearbox – 40mm	1	1	1	1		
13	GBRT300-45	Gearbox – 45mm					1	
13	GBRT400-55	Gearbox – 55mm						1
14	HYM130	Hydraulic motor	1					
14	HYM195	Hydraulic motor		1	1	1	1	1
15	135-4240	Roller (complete with bearings)	21	15	21	21	25	33
16	135-4247	Roller shaft	21	15	21	21	25	33
17	BRGYAR209-2F	Bearing – 45mm	2					
17	BRGYAR210-2F	Bearing – 50mm		2	2	2	2	2
18	HSGTU509	Bearing housing – 45mm	2					
18	HSGTU510	Bearing housing – 50mm		2	2	2	2	2
19	135-4261	Idler roller		1	1	1	1	1
19	135-4262	Idler roller - Mini	1					
20	-	See SmartAg Rate sensor section	1	1	1	1	1	1
21	135-0922	Roller shaft retainer (available on request)	1	1	1	1	1	1
22	135-4253	Roller bearing	4 per roller (2 have flanges machined)					
23	135-4190	Pinch roller bush	4	4	4	4	4	4
24	NY-T150	Conveyor Black PE Strip 100 X 3mm	2	2	2	2	2	2
25	10682	Side Retainer Strip 3T	2					
25	12324-24	Side Retainer Strip 4T		2				
25	10460-24	Side Retainer Strip 6T			2	2		
25	10518-20	Side Retainer Strip 8T					2	
25	10267-50	Side Retainer Strip 10T						2
26	135-0942	Front Rubber Flap 900 X 150	1	1	1	1	1	

Giltrap Fertiliser Spreader

Item	Part Number	Description	Quantity					
			2501	3801	3802	5001	6601	8301
26	13828	Front Rubber Flap 900 X 210						1
27	10683	Front Retainer Strip 3T	1					
27	12324-6	Front Retainer Strip 4T		1				
27	10460-6	Front Retainer Strip 6T			1	1		
27	10518-20	Front Retainer Strip 8T					1	
27	10267-19	Front Retainer Strip 10T						1

Spinner Assembly 2501 / 5001 / 6601 / 8301 / 10001 / 12401

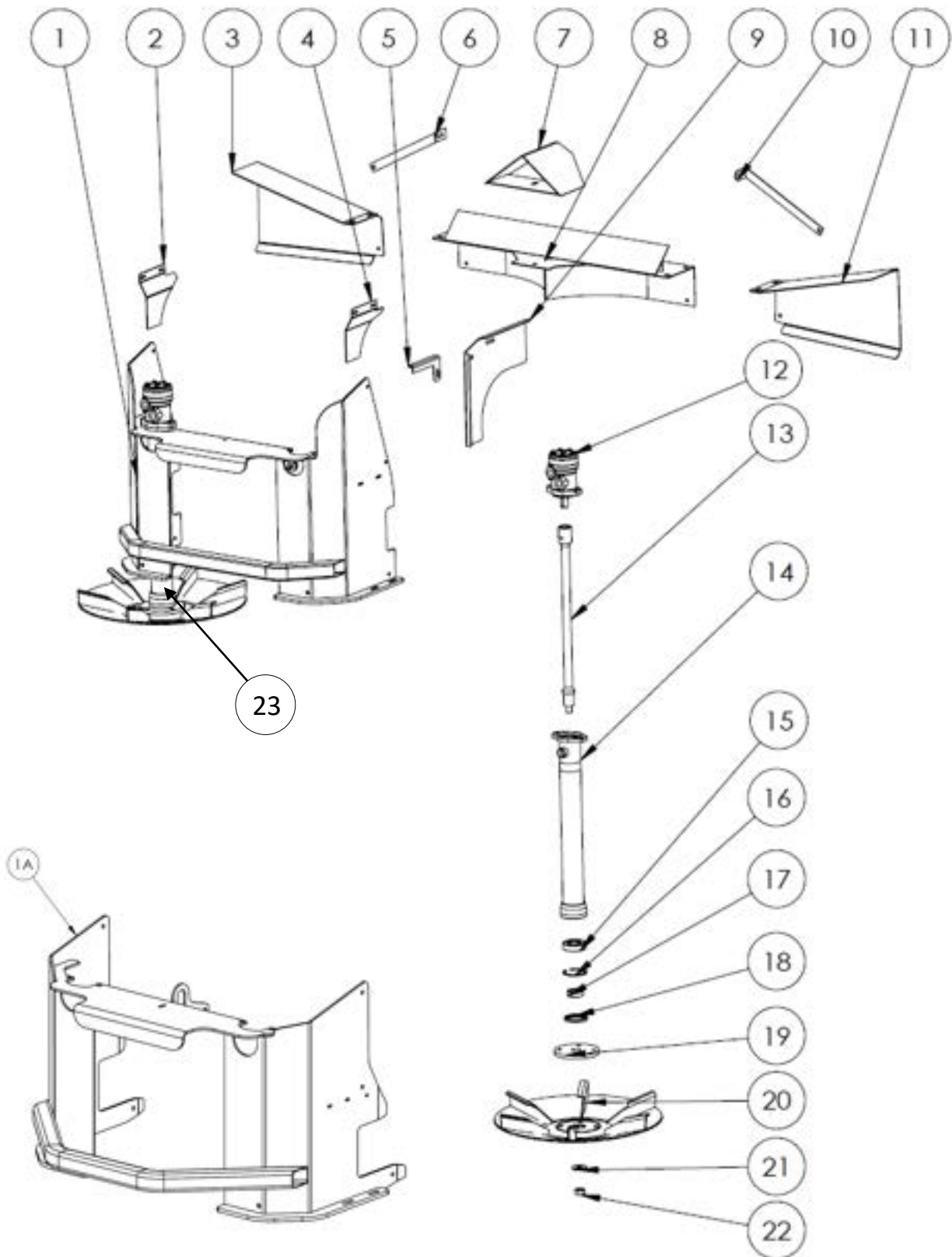





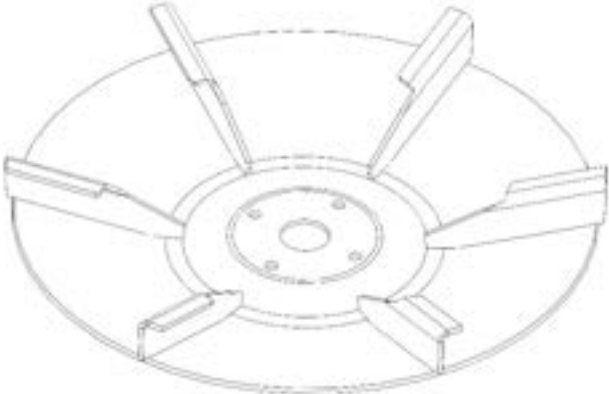
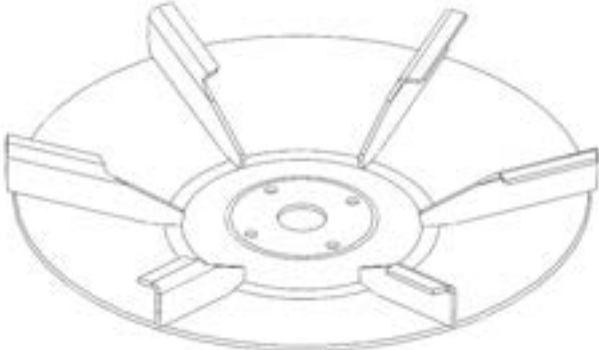
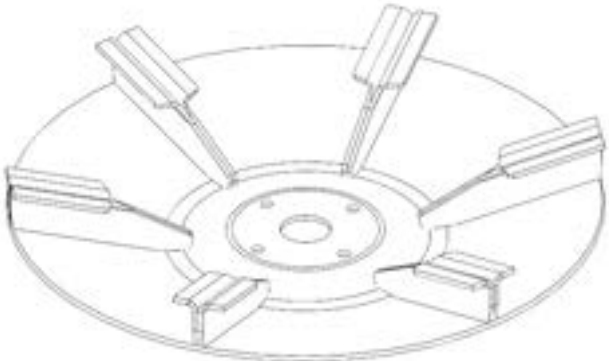
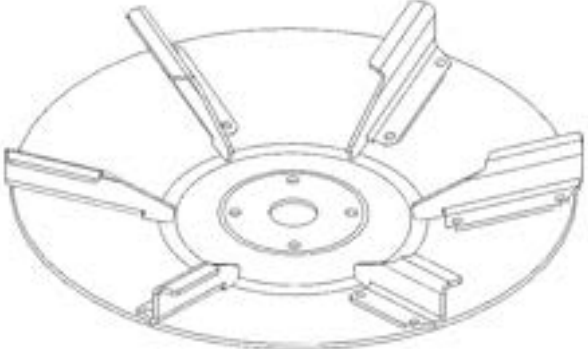

Spinner Assembly 2501 / 5001 / 6601 / 8301 / 10001 / 12401

Item	Part Number	Description	Quantity 5001 to 12401	Quantity 2501
1	13546	Spinner frame assembly – Large door	1	
1A	11282	Spinner frame assembly - Mini		1
2	135-0529L	LH Guide	1	
2	135-0531L	LH Guide - Mini		1
3	135-0603L	LH Deflector	1	
3	135-0607L	LH Deflector - Mini		1
4	135-0529R	RH Guide	1	
4	135-0531R	RH Guide - Mini		1
5	10279-11	Divider plate brace (available on request)	1	
6	135-0838L	LH Deflector brace	1	
7	135-3551	Tent	1	
8	135-3550	Discharge chute	1	
8	135-3545	Discharge chute - Mini		1
9	10279-7	Divider plate (available on request)	1	
9	135-0590	Divider plate – Mini (available on request)		1
10	135-0838R	RH Deflector brace	1	
11	135-0603R	RH Deflector	1	
11	135-0607R	RH Deflector - Mini		1
12	HYM32DAN	Hydraulic motor 32cc	2	2
12	HYM40COMM	Hydraulic motor Permco 32cc 2.5" commercial	2	2
13	135-4102	Spinner shaft	2	2
14	135-4112-LH	Spinner tube LH	1	1
14	135-4112-RH	Spinner tube RH (with sensor mount)	1	1
15	BRG6307	Bearing	2	2
16	CC180	Circlip	2	2
17	135-4200	Seal sleeve	2	2
18	SL558008	Seal	2	2
19	135-1048	Spinner mount plate	2	2
20	Spinner Disc	See table next page		
20	135-4080M	Spinner Multi	2	2
21	135-1069	Spinner center spacer	2	2
22	NN20	Nut	2	2
23	13590	Spinner Tube Assy, Complete	2	2

Note: Item #12 is dependent on what is fitted to a particular machine.

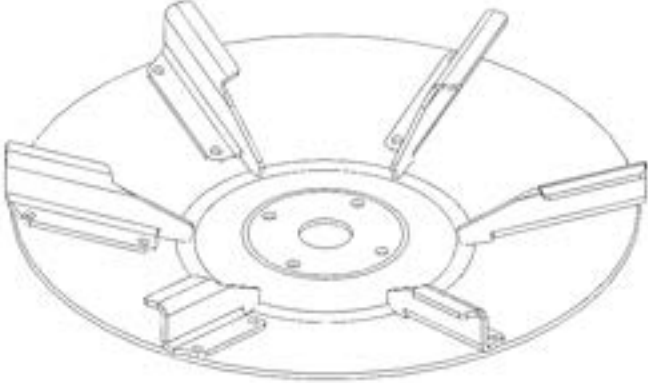
Spinner Disc Options

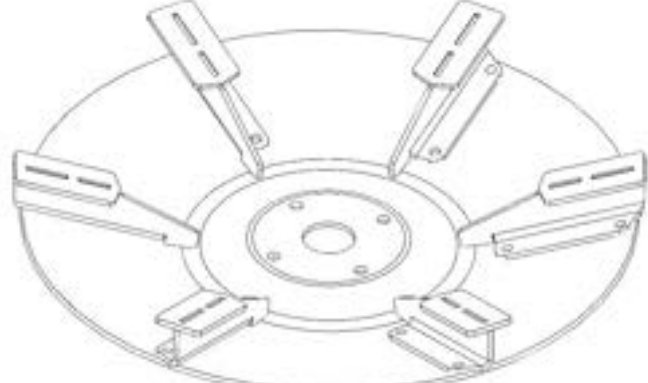
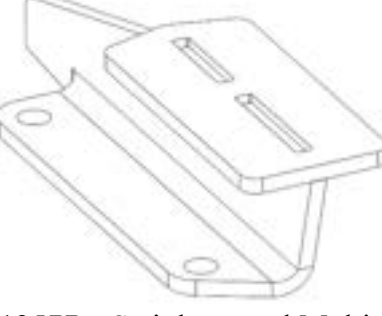
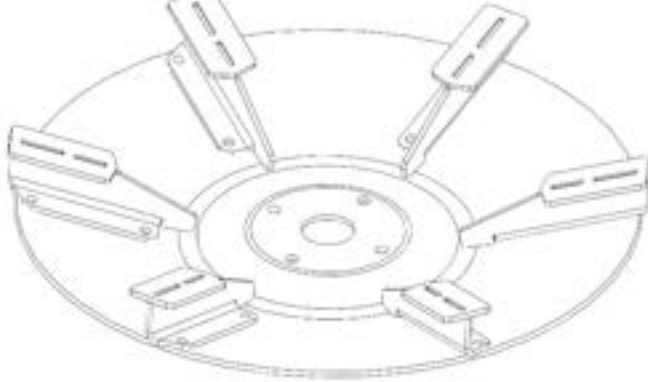
View	P/N & Description	
	<p>135-4080L</p> <p>Welded vanes - Left Hand Spinner disc</p>	<p>Painted Mild Steel</p>
	<p>135-4080R</p> <p>Welded vanes - Right Hand Spinner disc</p>	<p>Painted Mild Steel</p>
	<p>135-4080M</p> <p>Welded vanes - Multi-Directional Spinner disc</p>	<p>Painted Mild Steel</p>
	<p>13033</p> <p>LH Spinner Disc Assy, Stainless steel. Bolt-on vanes</p>	 <p>12951-2 - Stainless steel bolt on vane - LH</p>

	<p>13034</p> <p>RH Spinner Disc Assy, Stainless steel. Bolt-on vanes</p>	 <p>12951-3 – Stainless steel bolt on vane - RH</p>
	<p>13516</p> <p>LH Dual Side (Multi Directional) Spinner Assy, S/S</p>	 <p>13577 – Stainless steel Multi-Directional bolt on vane - LH</p>
	<p>13517</p> <p>RH Dual Side (Multi Directional) Spinner Assy, S/S</p>	 <p>13578– Stainless steel Multi-Directional bolt on vane - RH</p>

Hydraulic Rear Door Assembly

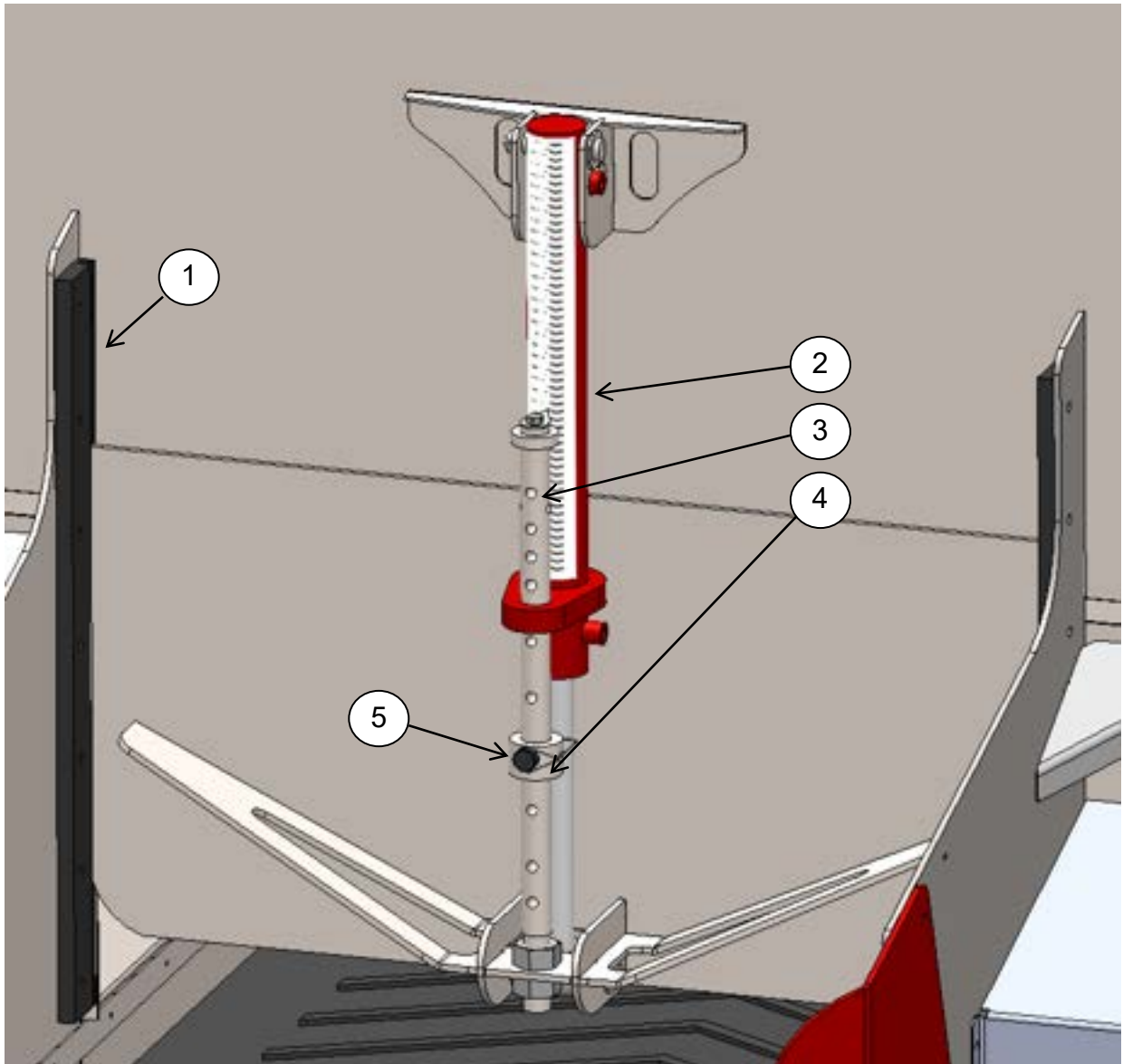

Item	Part Number	Description	Quantity
1	10517	Door slide	2
2	RAM1.5x1x380	Door ram	1
3	10285-10	Push rod	1
4	10285-11	Adjuster collar	1
5	S276	Shaft lock pin	1

Manual Rear Door Assembly

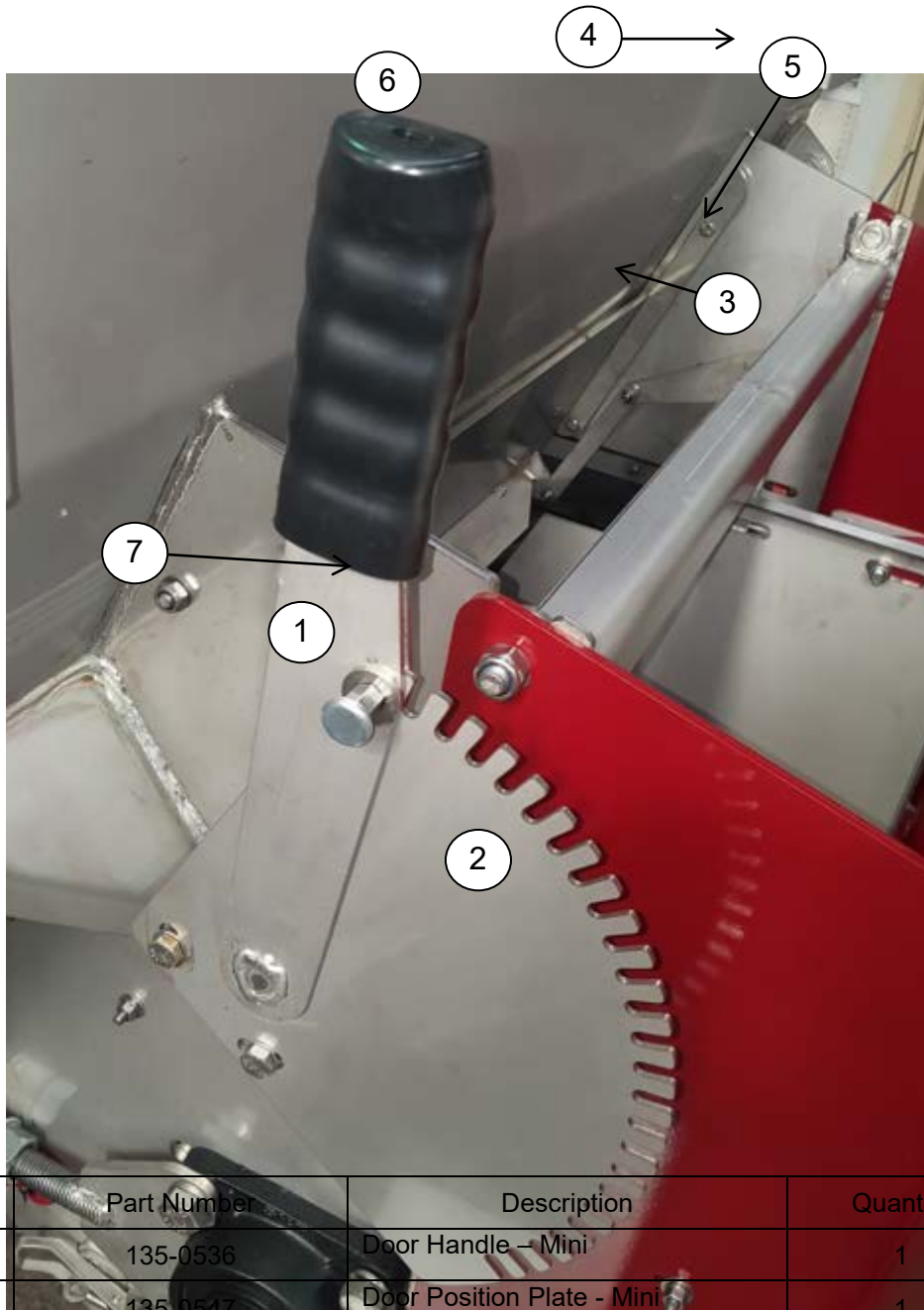

Item	Part Number	Description	Quantity
1	135-0536	Door Handle – Mini	1
2	135-0547	Door Position Plate - Mini	1
3	135-0562	Door Link Plate – Mini	2
4	135-0565	Door Guide Strip – Mini	2
5	135-0858	Door Pivot Arm Plate – Mini	2
6	135-4510	Adjuster Blk Hand Grip 33 ID	1
7	135-4533	Indexing Bolt S/S M10 – Fert	1

Axle Assembly

In the event of requiring a replacement axle, or components of an axle assembly please contact Giltrap Engineering with the following measurements, this is to ensure that we are able to provide the correct components in the event of differences to aid in the fitment of different wheel sizes.

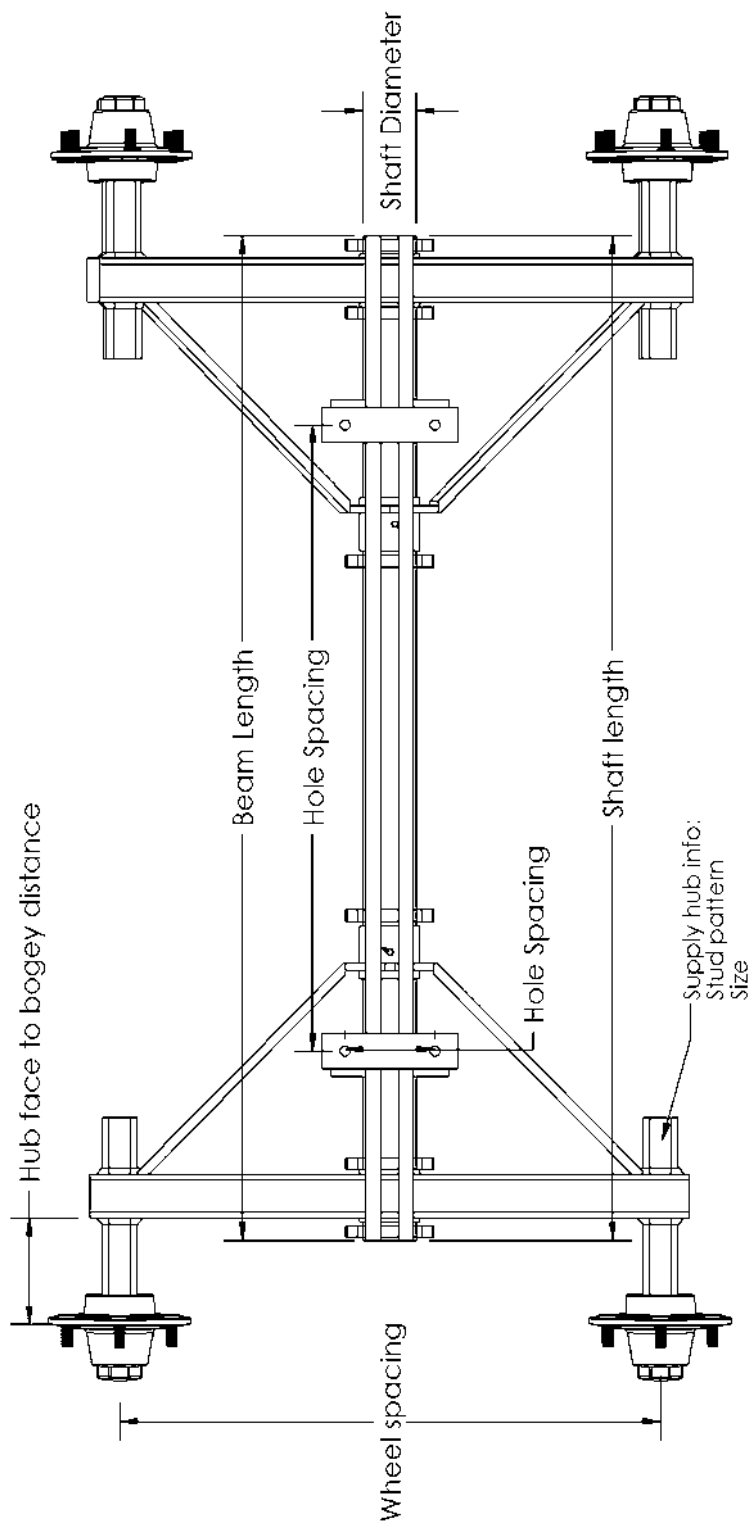

Modular Axle Assembly

Note: If you have non-standard sized wheels/tyres for your spreader, axle components may vary from the table below. In this case, please supply your tyre size when ordering components.

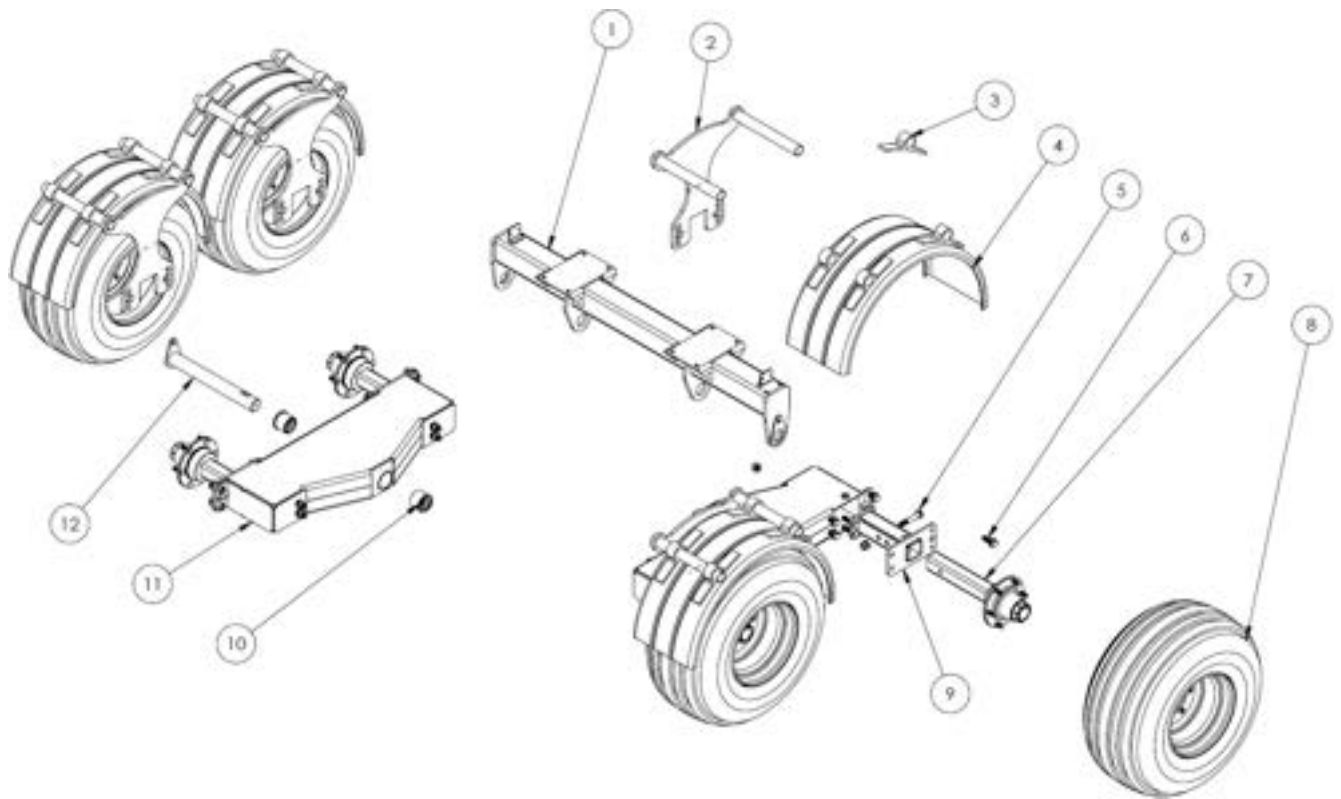

Item	Part Number	Description	Quantity		
			6T	8T	10T
1	13414	Axle Beam, SD, 6T Pro Series	1	-	-
1	13448	Axle Beam, HD, Pro Series	-	1	1
2	13071	400/60X15.5 Mudguard Mount	4	-	-
2	13592	400/55X22.5 Mudguard Mount	-	4	4
3	Mudguard Saddle	Mudguard Saddle	16	16	16
4	13504	Mudguard	4	-	-
4	Rhino PL1204	Mudguard	-	4	4
5	M20x120 Bolt	M20x120 Bolt	4	-	-
5	M24x130 Bolt	M24x130 Bolt	-	4	-
5	M30x150 Bolt	M30x150 Bolt	-	-	4
6	M20x60 Bolt	M20x60 Bolt	16	16	16
7	HUB3000KG	Hub 70Sq 6 Stud	4	-	-

Giltrap Fertiliser Spreader

Item	Part Number	Description	Quantity		
			6T	8T	10T
7	HUB4250KG	Hub 80Sq 8 Stud	-	4	-
7	HUB5000KG	Hub 90Sq 8 Stud	-	-	4
8	WHLA400X15.5-146T	Wheel Assy 400/60 X 15.5 - 6 Stud	4	-	-
8	WHLA400/55-22.5	Wheel Assy 400/55 X 22.5 - 8 Stud	-	4	-
8	WHLA500/45-22.5	Wheel Assy 500/45 X 22.5, 8 Stud	-	-	4
9	13464	70mm Hub Sleeve	4	-	-
9	13462	80mm Stub Insert Assy	-	4	-
9	13460	90mm Stub Insert Assy	-	-	4
10	13110	Axle Bush SD	4	4	4
11	12522	975 Walking Beam	2	-	-
11	13461	1250 Walking Beam	-	2	-
11	13457	1200 Offset Walking Beam	-	-	2
12	13109	Axle Shaft - 60mm	2	2	2

Hub Assembly – ADR

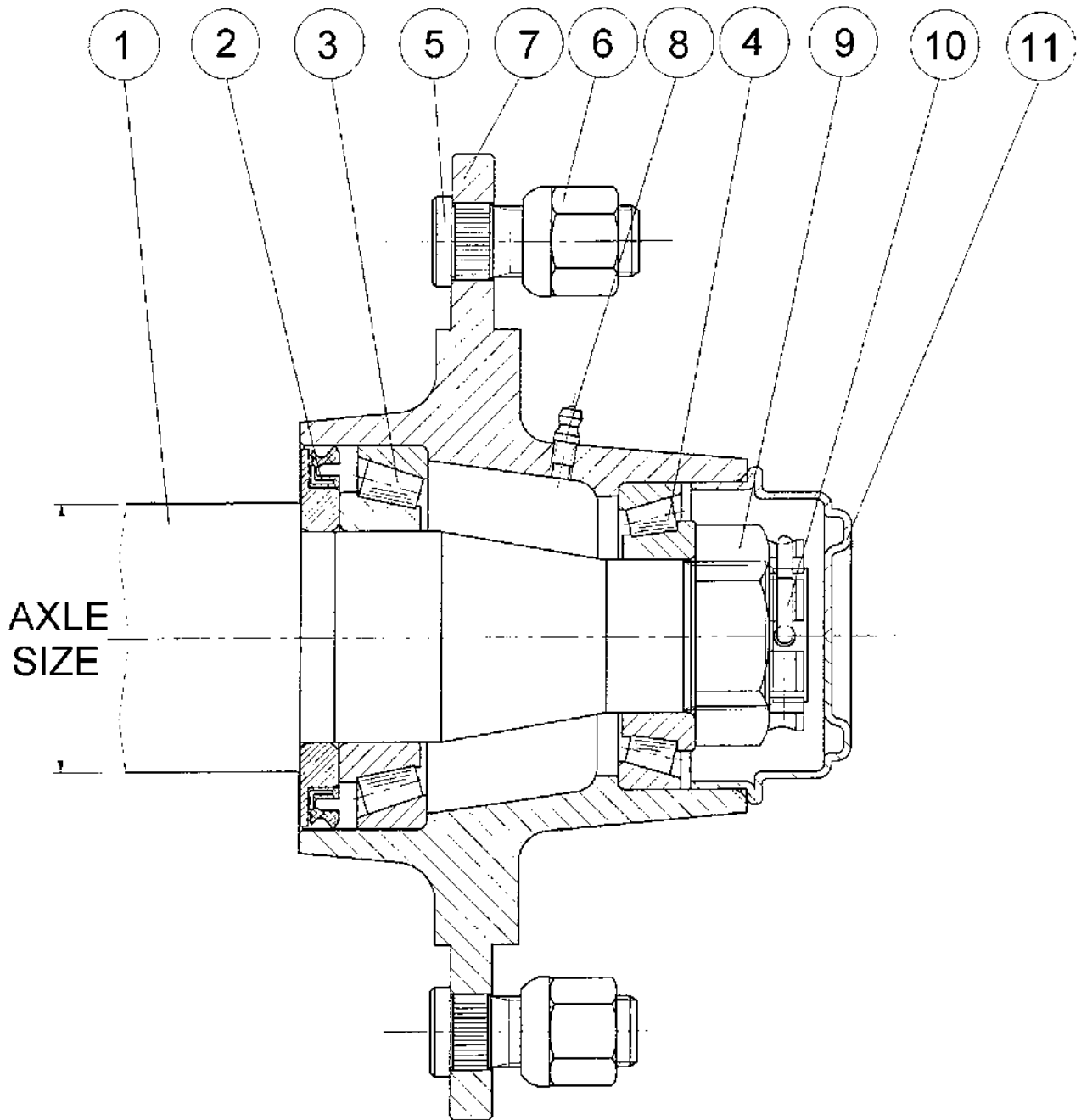

Hub Assembly – ADR

Item	Giltrap Part #	Description	Quantity			
			60mm	70mm	80mm	90mm
1	HUB2000KG	Complete Stub Axle, ADR 6 stud 60sq	1			
1	HUB3000KG	Complete Stub Axle, ADR 6 stud 70sq		1		
1	HUB4250KG	Complete Stub Axle, ADR 8 stud 80sq			1	
1	HUB5000KG	Complete Stub Axle, ADR 8 stud 90sq				1
2	110-0193	Seal 57x100x10 O/A (80x100x8 nom.)	1			
2	110-0194	Seal 67x120x12 O/A (100x120x10 nom.)		1		
2	110-0195	Seal 78x130x10 O/A (108x130x8 nom.)			1	
2	110-0196	Seal 82x140x10 O/A (119x140x8 nom.)				1
3	BRG30208J2	Taper Roller Bearing, 30208 J2	1			
3	BRG32210J2	Taper Roller Bearing, 32210 J2		1		
3	BRG32212J2	Taper Roller Bearing, 32212 J2			1	
3	BRG32213J2	Taper Roller Bearing, 32213 J2				1
4	BRG30211J2	Taper Roller Bearing, 30211 J2	1			
4	BRG30213J2	Taper Roller Bearing, 30213 J2		1		
4	BRG32215J2	Taper Roller Bearing, 32215 J2			1	
4	BRG32216J2	Taper Roller Bearing, 32216 J2				1
5	110-0945	Wheel Stud, M18x50	6	6	8	
5	110-0950	Wheel Stud, M20x60x1.5				8
6	110-0917	Wheel Nut, M18	6	6	8	
6	110-0919	Wheel Nut, M20x1.5				8
7	-	Hub Only	1	1	1	1
8	GRN8-45	Grease Nipple, M8x1.0 45 deg	1	1	1	1
9	110-1047	Slotted Nut, M39x1.5	1	1		
9	110-1060	Slotted Washer Nut, M48x1.5			1	1
10	-	Retaining Clip (or Split Pin SP5x70)	1			
10	-	Retaining Clip (or Split Pin SP5x70)		1		
10	-	Retaining Clip (or Split Pin SP5x80)			1	
10	-	Retaining Clip (or Split Pin SP5x90)				1
11	110-0799	Grease Cap ADR Pressed Steel - 80mm	1			
11	110-0881	Grease Cap ADR Pressed Steel - 90mm		1		
11	110-0883	Grease Cap ADR Pressed Steel - 110mm			1	
11	110-0884	Grease Cap ADR Pressed Steel - 120mm				1

Monroc 60mm Hubs

Balloun	Quantity	Code	Name
A	1	479600000 - L	stub axle body square 60 30
B	1	361000700A	protective metal seal
C	1	416291001A	ring seal lip contact 55x75x13
D	1	330191001	2 lips AS 72x105x10 400
E	1	30211	Bearing
F	6	331100000	stud 8x15
G	1	412900001A	80% rev. ss
H	6	331400700	nut M18x15
I	1	30207	Bearing
J	1	361300000	washer 50x31x4
K	1	330200100	nut M6 M06x200
L	1	336200700	pin 8x30
M	1	324100400A	cup M72.5x150
N	1	327100100	grease nipple 88 (option)

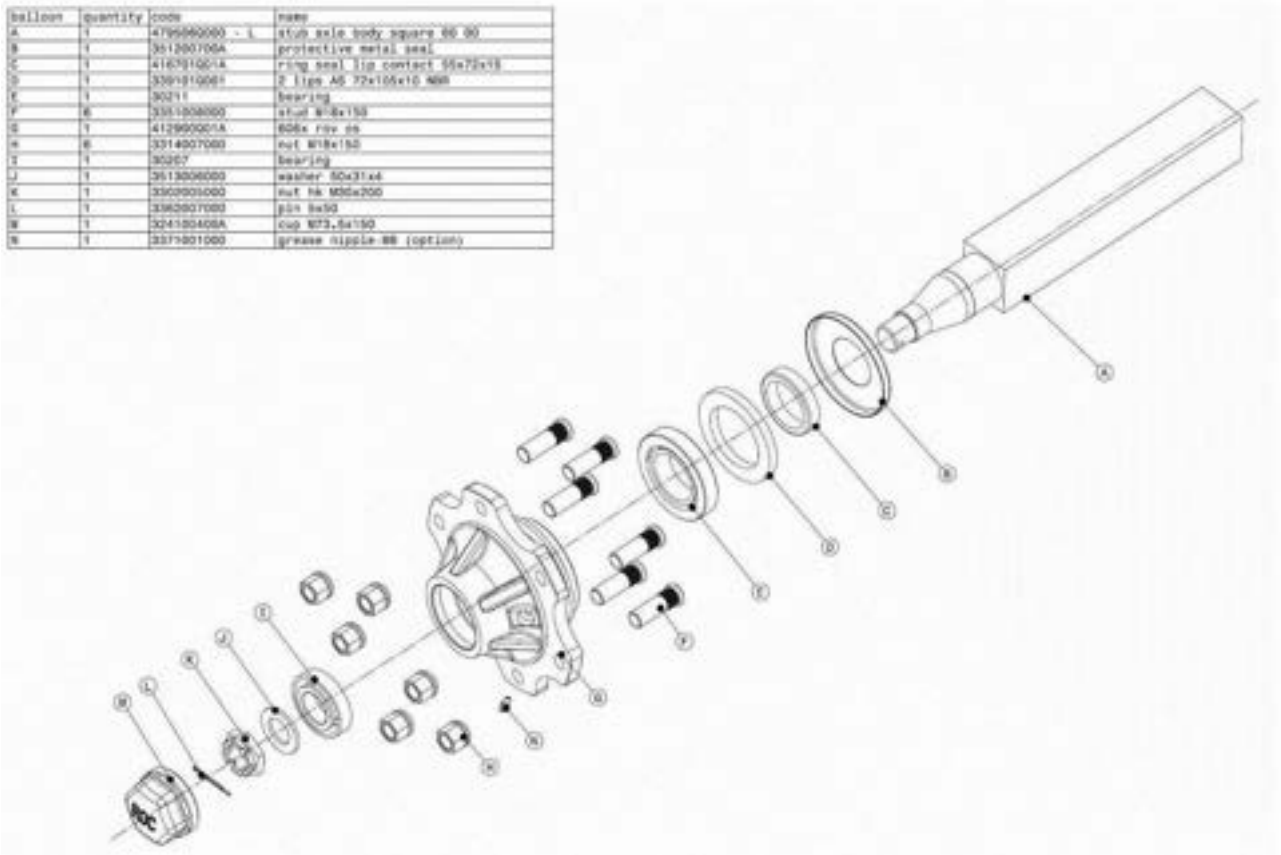

Balloun	Quantity	Code	Name
A	1	479100000 - L	Body stub axle 40MMF1 300x60C
B	1	333400000	Brake cover - 300x60C
C	2	440300000	Brake shoes 300x60C
D	1	347200000	Brake cover axle 300x60C
E	2	348200000	Spring 518
F	1	427400001A	Case 300x60C 1g300
G	1	365100420	Case support 300x60C
H	1	418200000	Brake lever
I	1	326100100	Clips 604
J	1	361200000	Washer - 50x31x2
K	1	30211	Bearing 30211
L	6	331100000	Stud M8x15
M	1	441300000 - 06	W68 60% revMFT 300x60C
N	6	331400700	Wheel nut M18x15
O	1	30208	Bearing 30208
P	1	361300000	Washer 50x31x2
Q	1	330200100	Nut M6 M06x200
R	1	336200700	Pin 8x30
S	1	324100000	Cup M72.5x150
T	1	327100100	GREASE NIPPLE 88 (OPT100)

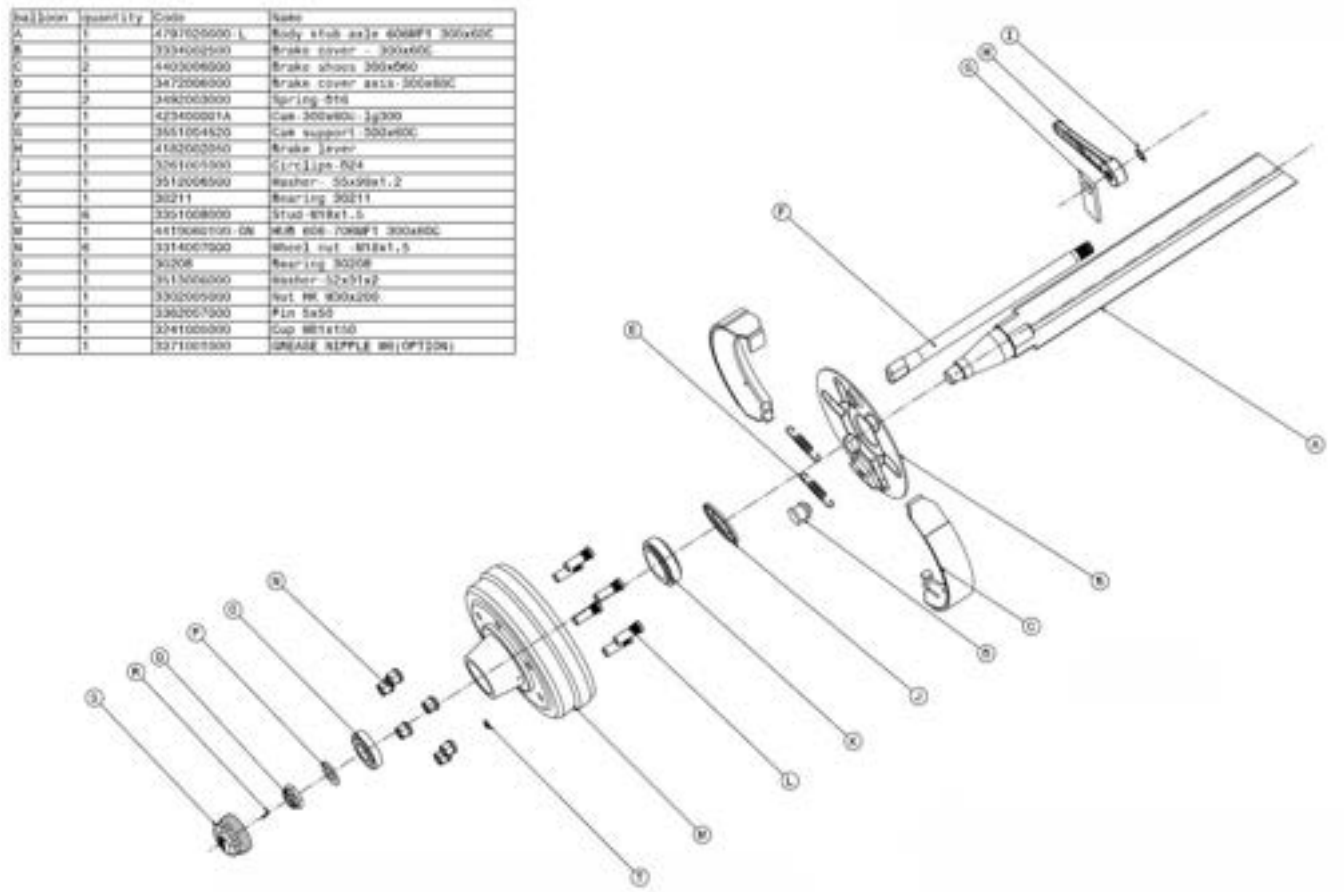

Monroc 70mm Hubs

Ballon	Quantity	Code	Name
A	1	4794270000-L	STUB AXLE BODY SQUARE TO 30
B	1	3510010000	ROD WASHER 60x131x2
C	1	4167010024	AXIAL SEAL LIP CONTACT 65x80x38
D	1	3391010003	SEAL AS 80M 80x170x12
E	1	30213	BEARING 30213
F	6	3351000000	STUD M18x1.5
G	1	4129000000	70MM ROD OD
H	6	3314007000	WHEEL NUT 87x1.5
J	1	30209	BEARING 30209
K	1	3513000000	WASHER 36x70x5
L	1	3302000000	NUT NK 40x150
M	1	3362000000	PIV 5x80
N	1	3241000000	CUP 60x150
O	1	3311001000	GREASE NIPPLE (E/OPTION)

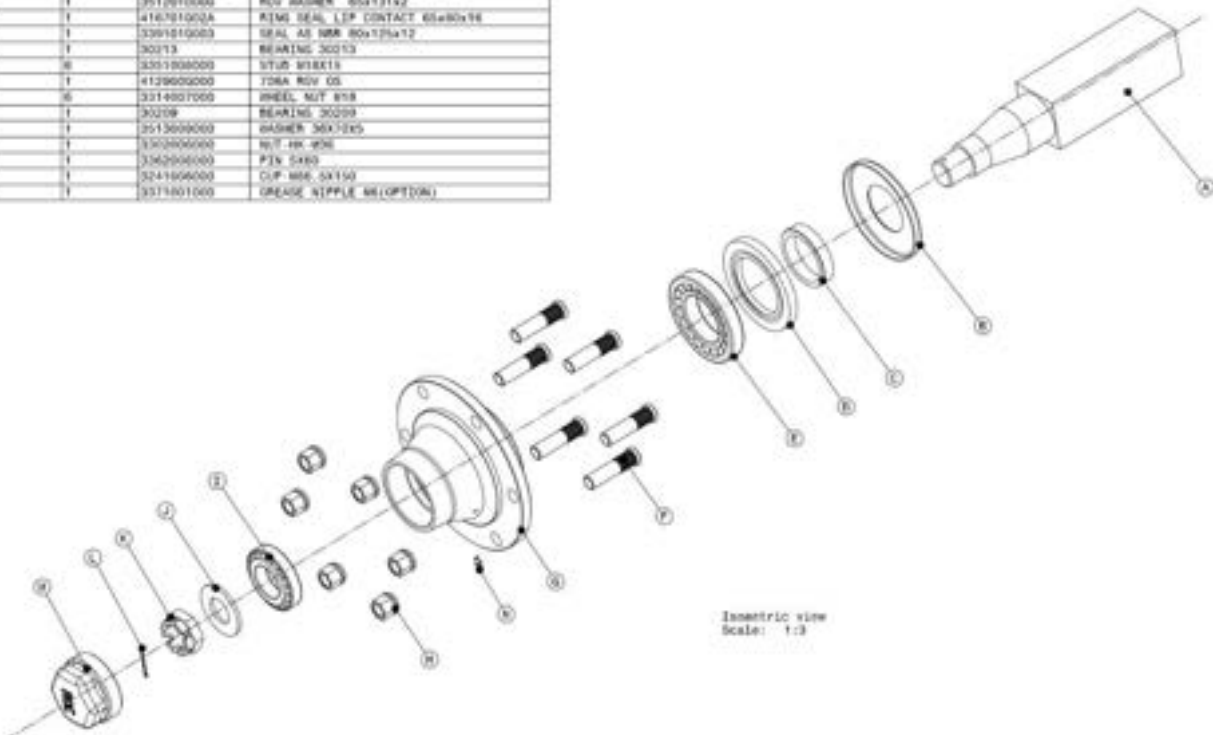

Ballon	Quantity	Code	Name
A	1	4791900000-L	Body STUB AXLE 70MM 300x60C
B	1	3334003000	Brake cover - 300x60C
C	2	4403006000	Brake shoes 300x560
D	1	3472006004	Brake cover axis 300x60C
E	1	3490003000	Spring 378
F	1	4204000014	Cam 300x60C 1g300
G	1	3511007000	Cam support 300x60C
H	1	2182006100	Brake lever
J	1	3261001000	Circlip 504
K	1	3513023000	Washer 60x118x4
L	1	30213	Bearing
M	6	3351000000	Stud M18x1.5
N	1	4418000100	Hub 70MM 300x60C
O	6	3314007000	Wheel nut 87x1.5
P	1	30209	Bearing
Q	1	3513000000	Washer 36x70x5
R	1	3302000000	Nut NK 80x150
S	1	3362000000	Piv 5x80
T	1	3241000000	Cup 60x150

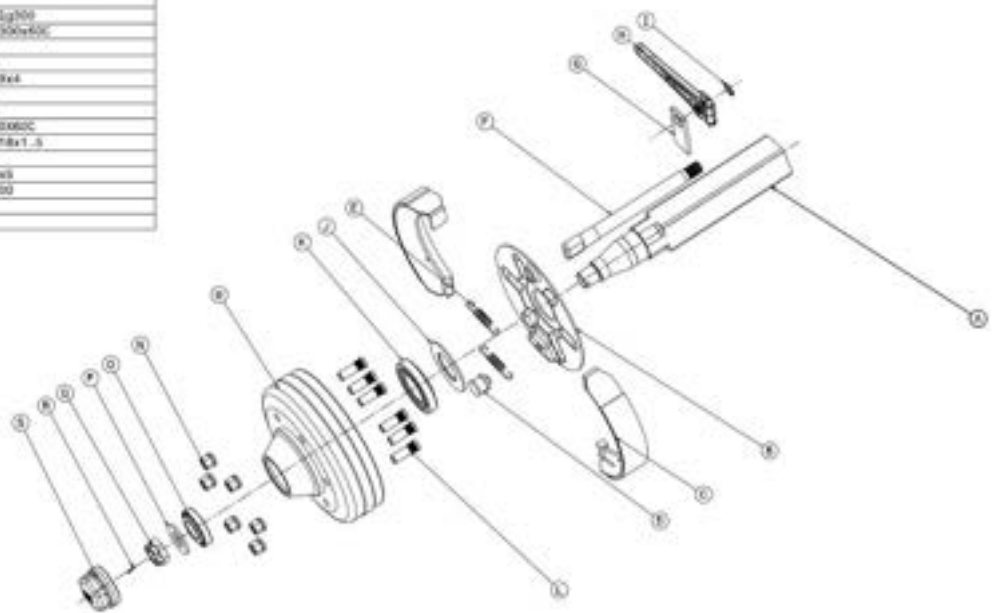

Monroc 80mm Hubs

Ballon	quantity	code	name
A	1	479546000 L	BODY STUB AXLE SCREW 80x80
B	1	351200800	NOV 75x14x2
C	1	416751000	RING SEAL LIP CONTACT 75x96x16
D	1	330701000	SEAL 2 LIPS AS 91x130x13 MM
E	1	30215	BEARING 30215
F	8	335100800	STUB 818x150
G	1	412900200	HUB 80x 80V 28
H	1	337100100	GREASE nipple 80 (OPTION)
I	8	331400800	NUT 818 305PL27
J	1	32211	BEARING 32211
K	1	351301800	WASHER 45x80x5
L	1	330200800	NUT 80 845x200
M	1	336500800	Pin 6x7
N	1	324100004	Cup 810x150

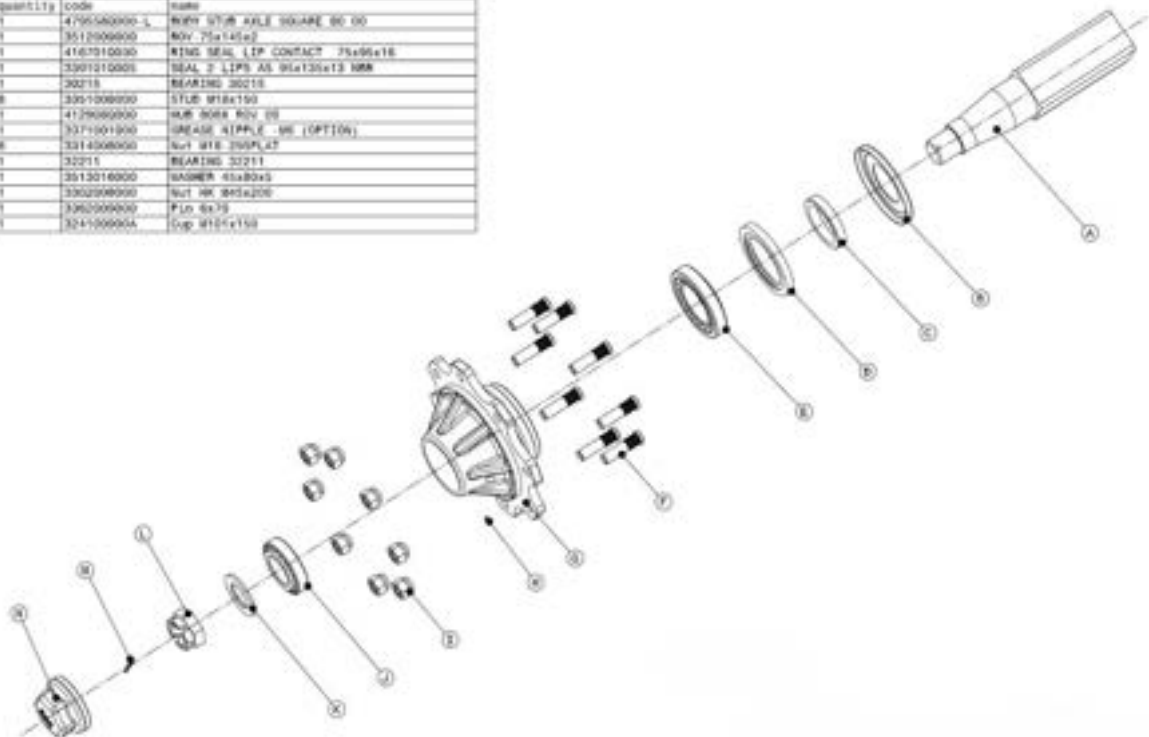

Ballon	quantity	Code	Name
A	1	479853400 L	BODY STUB AXLE SCREW 400x80C
B	1	326190300	CLIP/CLIPS 033
C	1	418200200	BRAKE LEVER
D	1	361918100	CAM SUPPORT 400x80C
E	1	423600400	CAM 400x80 1/260
F	4	320307100	SCREW TR BRK 25 L*20
G	2	378000110	BRAKE COVER 400x80C
H	2	340011300	SPRING
I	2	340611300	BRAKE SHOE 400x80C
J	2	337907100	GREASE nipple 80
K	1	316100200	ROTH 2850P2
L	1	578000080	SPIDER 400x80C
M	1	330900000	O RING SEAL 35x7
N	1	451302700	SCAMER 75x130x10
O	1	30215	BEARING 30215
P	8	335101800	STUB 818x150
Q	1	405011300	HUB 40x80C
R	1	441400800	HUB 80x 908 075
S	8	331400800	NUT 818 305PL 5
T	1	32211	BEARING 32211
U	1	351301800	WASHER 45x80x5
V	1	330200800	NUT 80 845x200
W	1	336500800	Pin 6x7
X	1	324100800	CUP 810x150

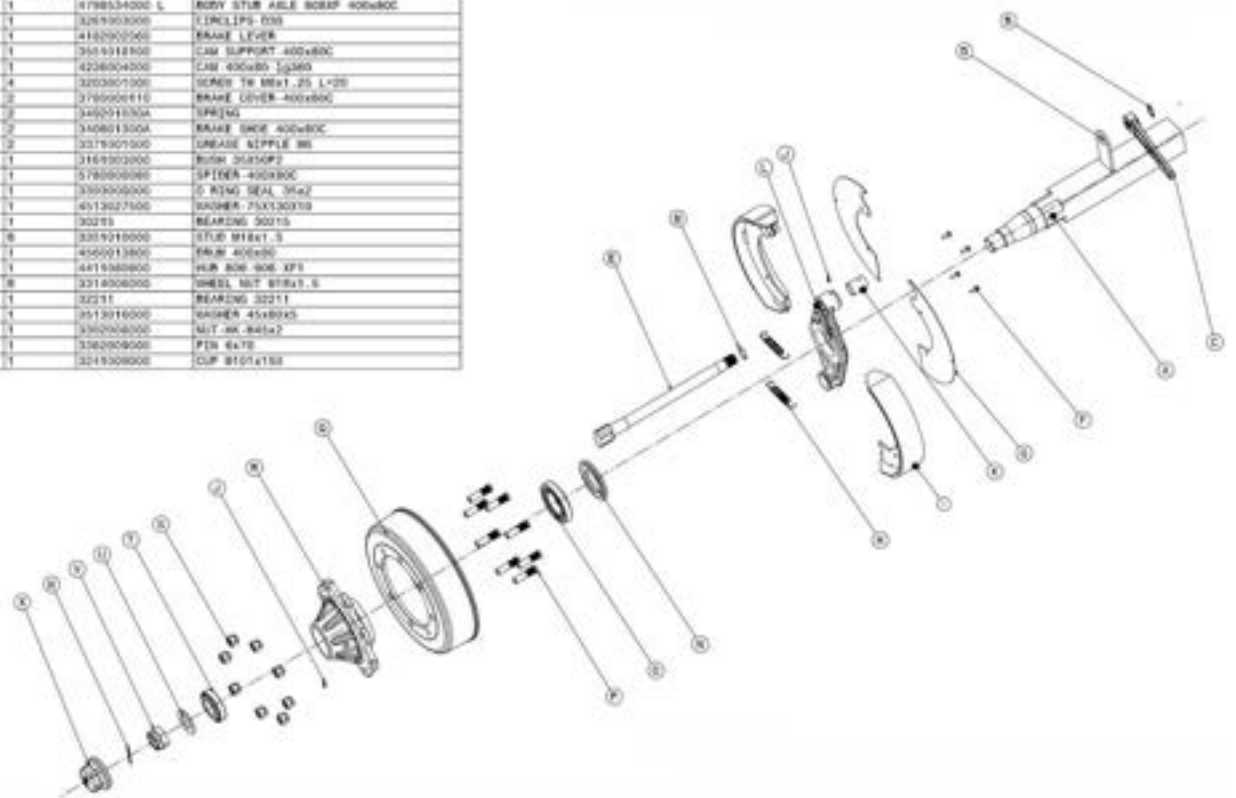

Monroc 90mm Hubs

Item	Quantity	Code	Name
A	1	4795590000-L	BODY STUD AXLE SQUARE 30 50
B	1	3512011504	ROV WASHER -85x167x10
C	1	3391320000	BEARING 32217-COMPACT TR LIP SEAL
D	8	3351307000	STUD 878x150
E	1	4418081000-GR	HUB 90X85-EPB
F	8	3312001000	WHEEL NUT 878x150
G	1	32217	BEARING 32217
H	1	3362030000	STEEL SEAL-32217
I	1	3302009500	NUT HW-95x200
J	1	3364001904	PIA 800N
K	1	3241316800	CUP-8165x200
L	1	3371301000	GREASE NIPPLE-GR (OPT296)

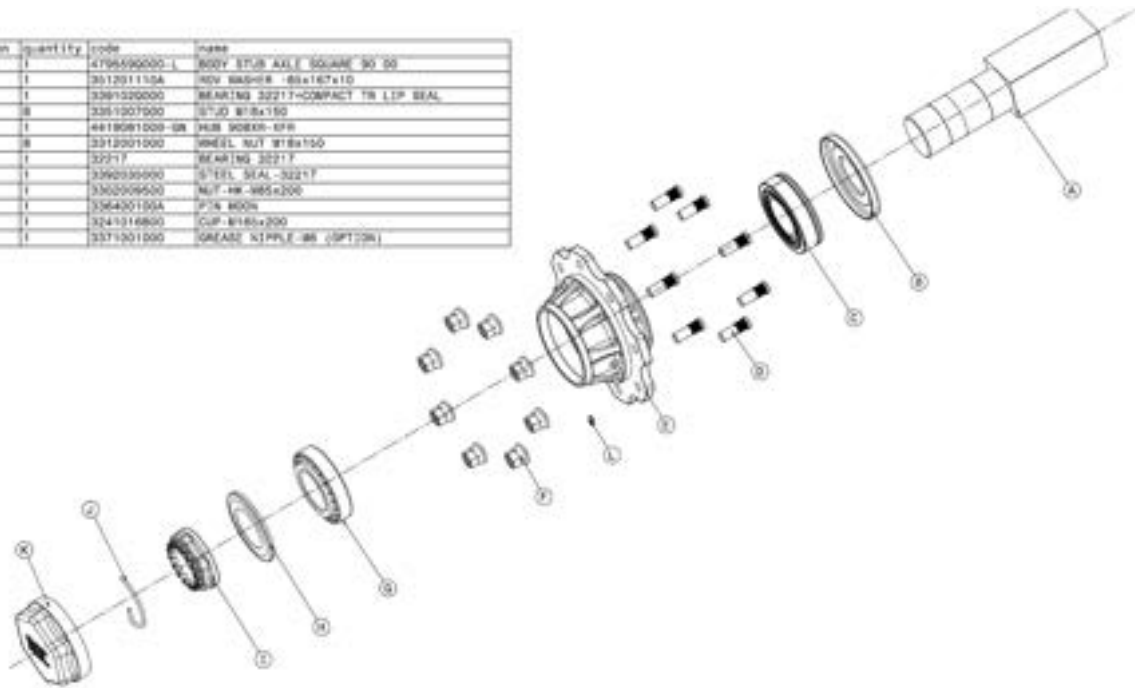

Monroc 100mm Hubs

Ballon	Quantity	Code	Name
A	1	4794580210-800	BODY STUB AXLE SQUARE 90 CARRE 100 Ø1
B	1	351201110A	ROV WASHER -85x187x13
C	1	3391020000	BEARING 32217-COMPACT TR LIP SEAL
D	8	3351008000	STUD Ø18x150
E	1	4419081008-08	HUB Ø50x8-xFR 1008x-ØF
F	8	3312001000	WHEEL NUT M18x150
G	1	32217	BEARING 32217
H	1	3382006000	STYH SEAL-32217
I	1	3302008008	NUT -HK-885x200
J	1	336400100A	PIN 8008
K	1	324101880A	CUP Ø185x200
L	1	3371001000	SHASE NUTPLE-88 (OPT106)

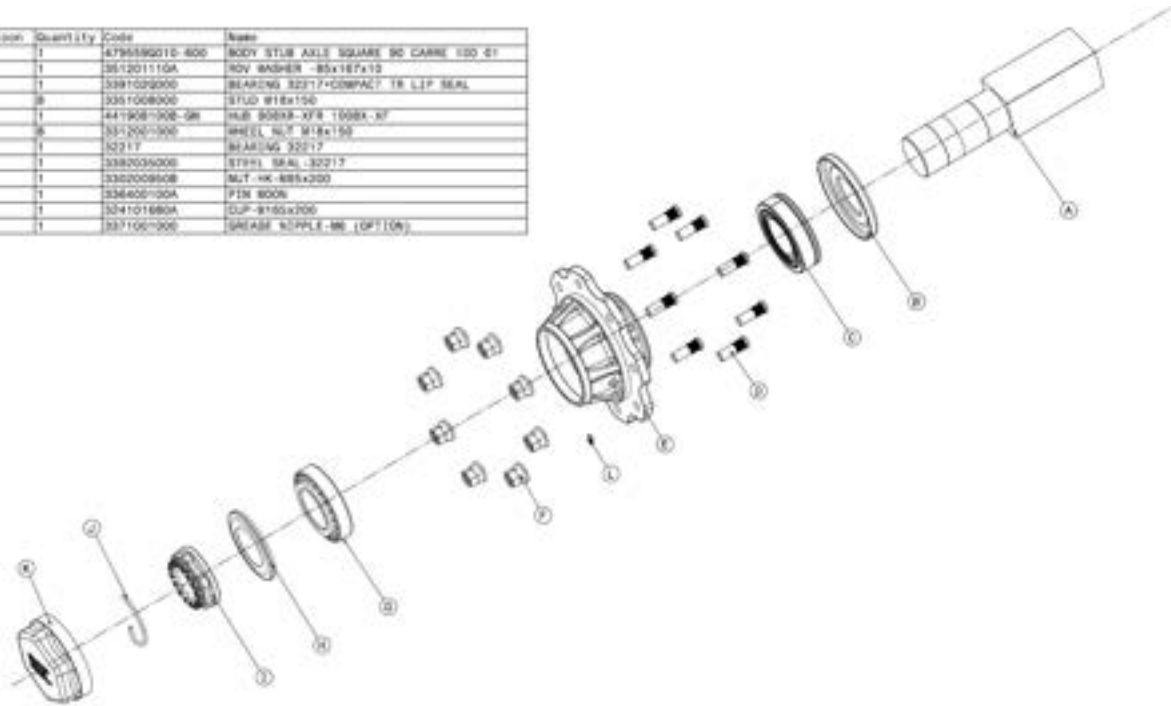

Ballon	Quantity	Code	Name
A	1	4794580210-800	BODY STUB AXLE 100Øx750 SQUARE 100 Ø1
B	1	3361003000	C1-CLIP 230
C	1	418100100A	SHASE NUTPLE
D	1	3511018000	CAR SUPPORT-400x800
E	1	4234001000	CAR-600x80-102800
F	4	3320001000	SCREW 10x8x1,25 L=20
G	2	3780000110	BRAKE COVER-400x800
H	2	348201236A	SPRING
I	2	3428013000	SHASE NUT 400x800
J	1	3371001000	SHASE NUTPLE 88
K	1	3181003000	CLIP 36x50x3
L	1	3180001000	SP-36x-400x800
M	1	3390002000	O-RING SEAL 36x2
N	1	351201110A	ROV WASHER 85x187x13
O	1	3391020000	BEARING 32217-COMPACT TR LIP SEAL
P	8	3351010000	STUD M18x150
Q	1	4480013800	SHASE 400x800
R	1	4419081008-08	HUB Ø50x8-xFR 1008x-ØF
S	8	3312001000	WHEEL NUT M18x150
T	1	3371001000	SHASE NUTPLE 88 (opt106)
U	1	32217	BEARING 32217
V	1	3382006000	STYH SEAL-32217
W	1	3302008008	NUT -HK-885x200
X	1	336400100A	PIN 8008
Y	1	324101880A	CUP Ø185x200

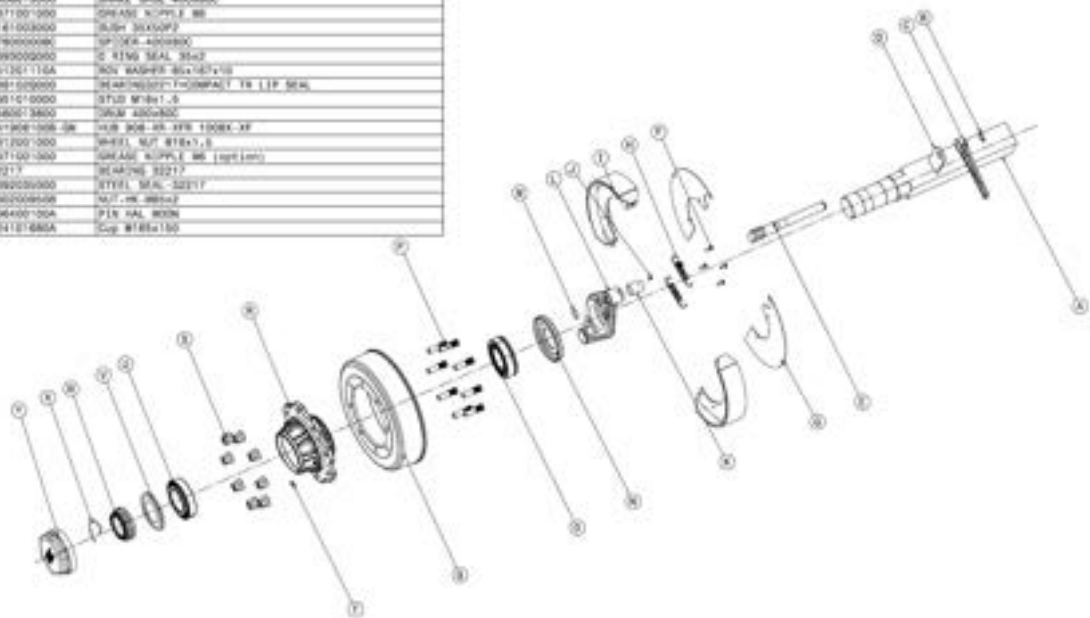

Ref/loc	Quantity	Code	Name
A	1	4793997500-893	NOSE TUB ASLE 1810078 400x80C
B	1	379 1001000	CLIP 175-212
C	1	8182027004	SPARE LEVER
D	1	3511014100	CAM 3077021-800x80C
E	1	4736001000	CAM 401x80 1g360
F	18	3703001000	SCREW 78 M8x1 13 1276
G	2	3790001113	BEARING COVER-400x80C
H	7	8692010388	SPRING
I	7	5406011000	SPARE SPR 400x80C
J	1	5790005080C	SPIDER-400x80C
K	1	4438001834	WASHER-191108-11101
L	7	3392038300	STEEL SEAL-32719
M	7	32719	BEARING-32719
N	7	3392038350	STEEL SEAL-32719
O	18	3551014000	STUD M32x150
P	1	8549013630	DRUM 800x80C
Q	1	4418041000	WIP 101100-11100
R	1	3311001000	SPARE NIPPLE W/COUPLER
S	18	3512002000	WHEEL NUT M27x150
T	1	330201000A	NUT M8-M30x2
U	1	334400100A	PIN BAL WOOD
V	1	324101700A	CUP M10x120

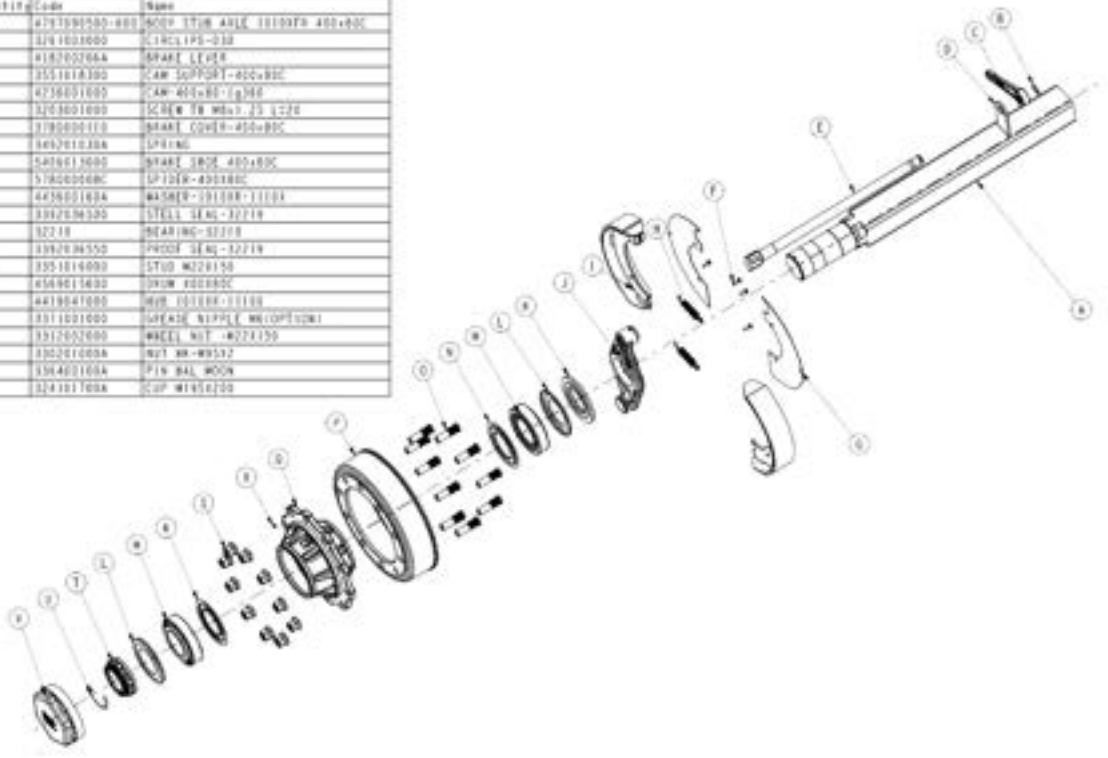

Door Control Valve – HYHCV-3213

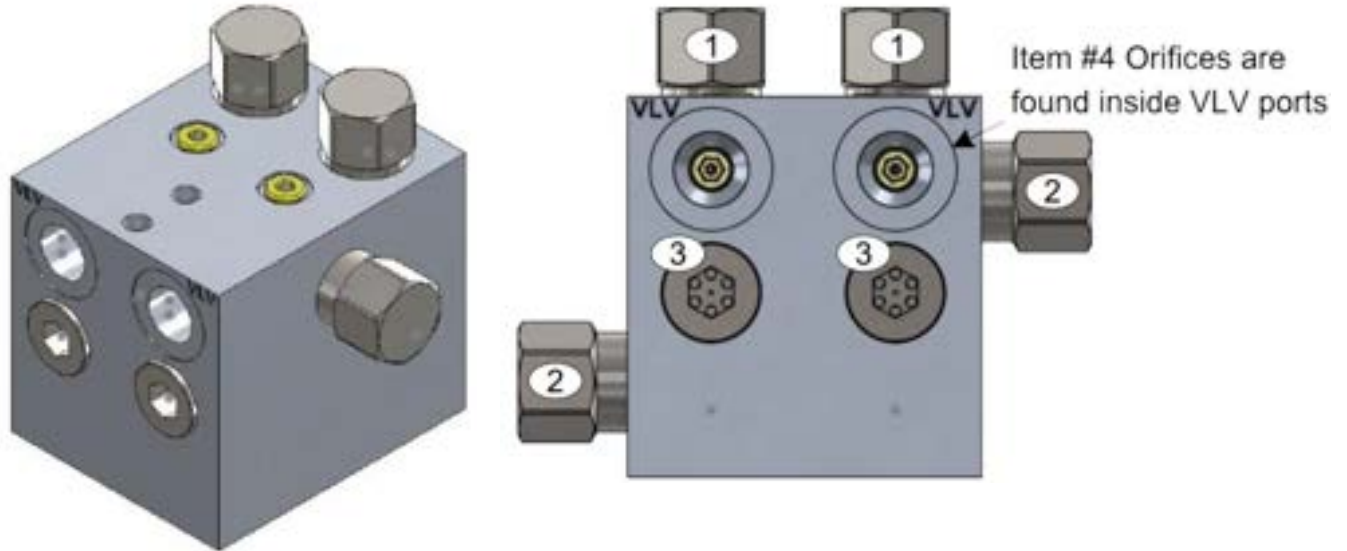

Position	Qty	Supplier Part #	Description	Setting
1	2	CKBD XCN	P.O. Check valve	30psi
2	2	RDBX XAN-1000	Relief valve – Fixed setting	1000psi
3	2	CXBG XAN	Check valve (Flush)	4psi
4	2	1/16" x 1.0	1/16"NPT x 1.00mm orifice	

Spreader Control Valve – HYHCV-3542 – To fit 3801 - 12401

This is the standard configuration for the valve block
(Conveyor in series, spinners in parallel)

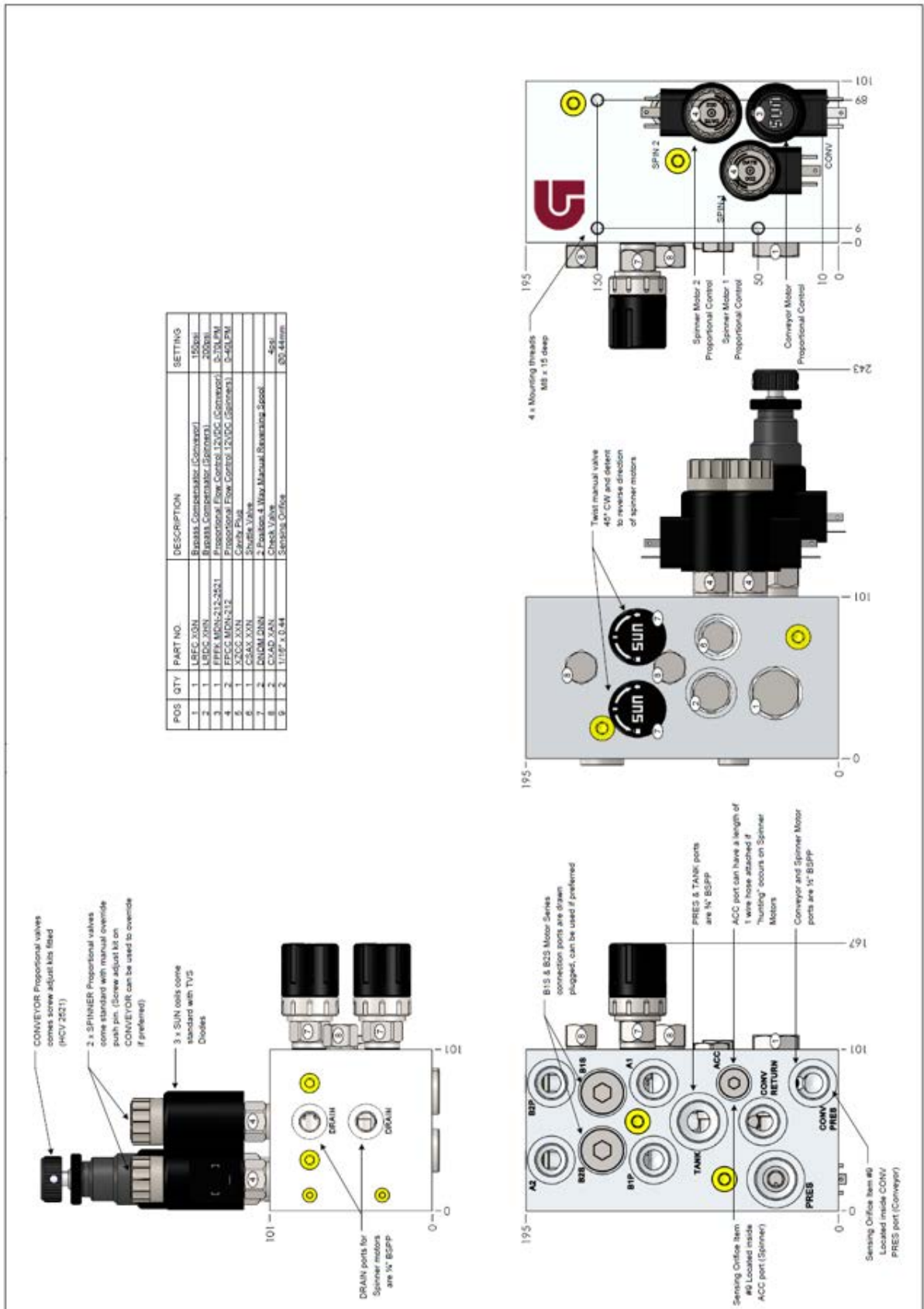

Spreader Control Valve – HYHCV-3656 – To fit 2501

This is the standard configuration for the valve block
(Conveyor in series, spinners in parallel)

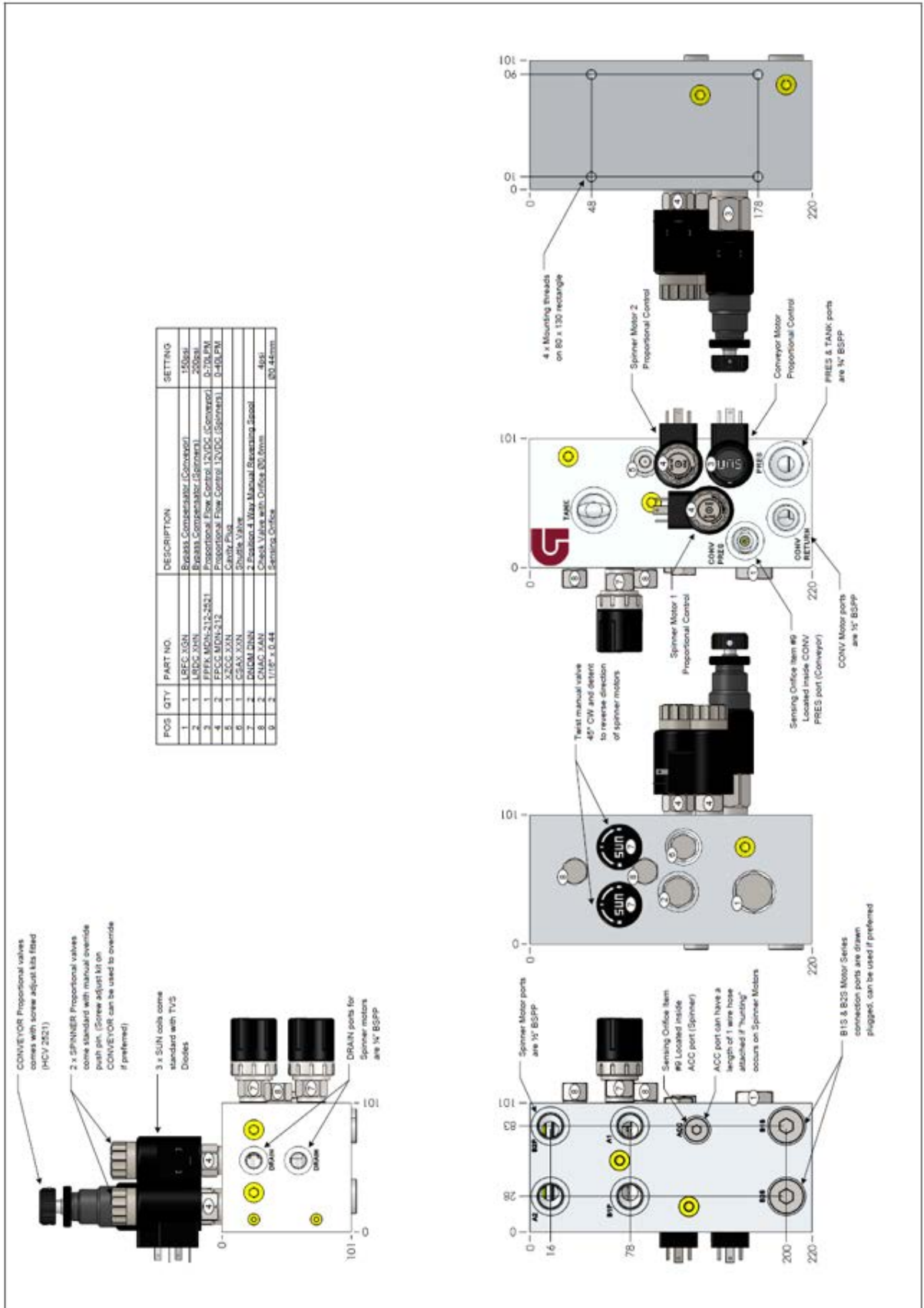

Gearbox Details – RT200

Oil replacement: SAE90 EP (2.3L)

Riduttore RT200 Ø45		CODICE 9358	
Fig.	Rif.	Descrizione	Qt.
1	9360	Scatola RT200	1
2	8670-8	Mozzo Ø45	1
3	9347	Ruota d'entrata Z=53	1
4	8703	Seegeri F 72	1
5	8702	Cuscinetto 60*3	2
6	3439	Seegeri I 100	2
7	9346	Pignone di rinvio Z=18	1
8	9359	Corona Z=31	1
9	3401	Chavetta 10x3x25	2
10	3333	Cuscinetto 6207	1
11	3435	Seegeri I 80	2
12	3434	Seegeri I 72	1
13	3339	Cuscinetto 6307	1
14	9255	Pignone Z=10	1
15	1638	Cuscinetto 60*0	1
16	3428	Seegeri E 50	1
17	8701	Anello di ten. 65/130/10	2
18	8243	Tappo Ø88 sp 10	1
19	8490	Tappo Ø72 sp 10	1
20	1257	Spia liv. olio Ø1/2"Gas	1
21	5689	Tappo sfiato Ø1/2"Gas	1
22	8671	Guarnizione x motore	1
23	9361	Guarnizione copriolio	1
24	9362	Coperchio	1
25	3284	Vite TE M8x19-80	6

Gearbox Details – RT300

Oil replacement: SAE90 EP (3.8L)

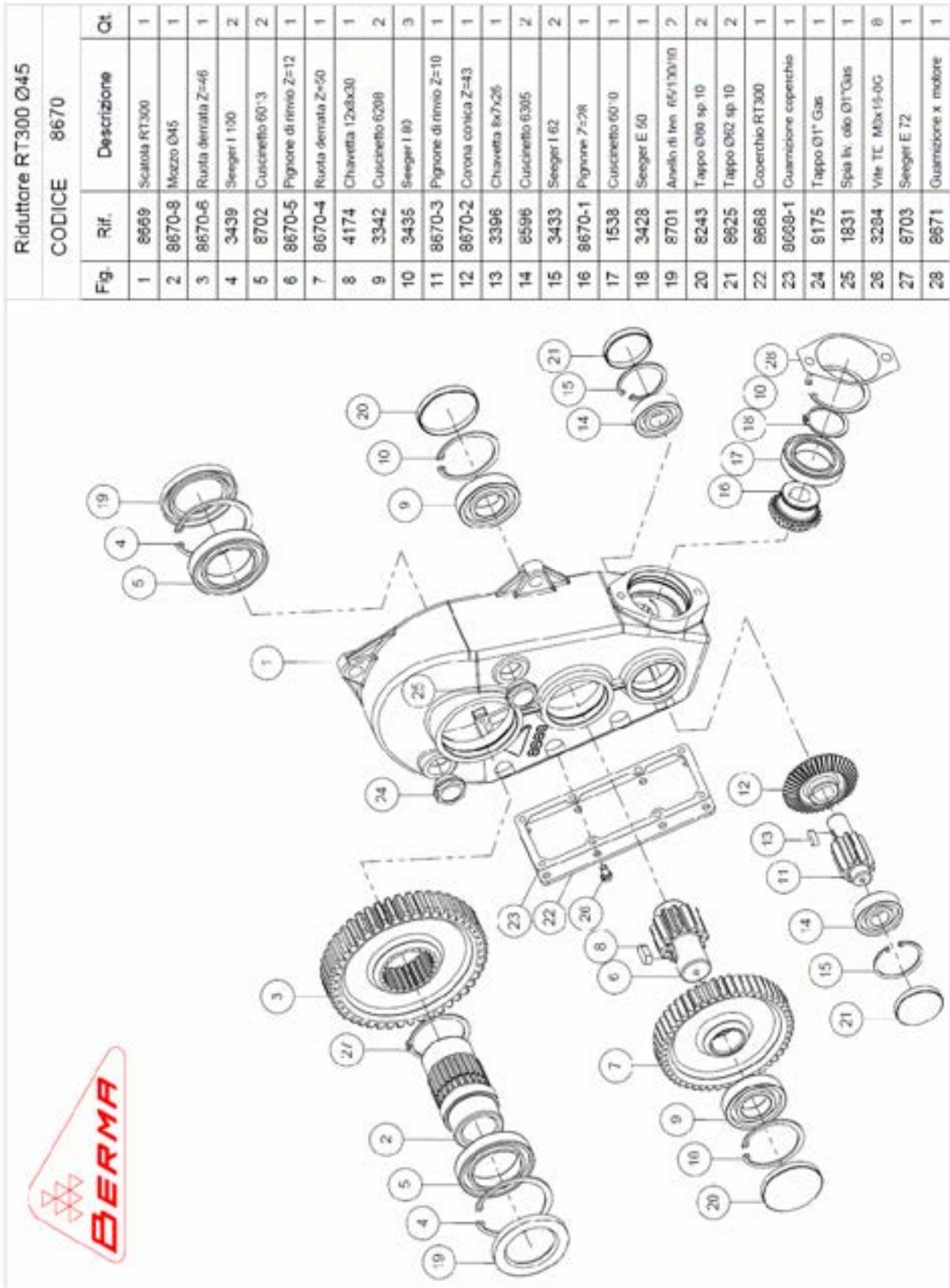

Gearbox Details – RT400

Oil replacement: SAE90 EP (4.3L)

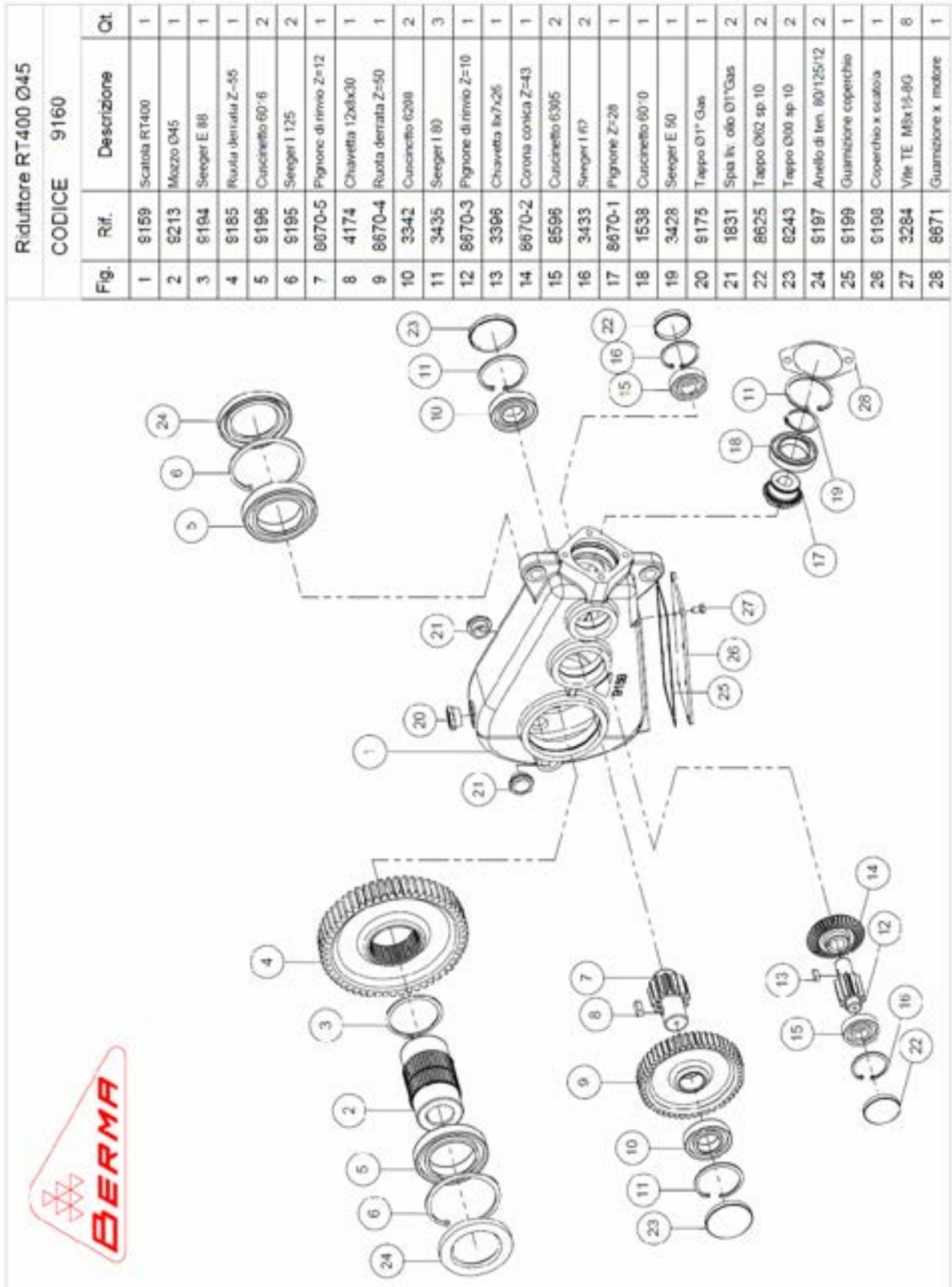

Gearbox Details – RT400-2V

Oil replacement: SAE90 EP (5L)

Riduttore RT400-2V Ø55			
CODICE 9222			
Fig.	Rif.	Descrizione	Qt.
1	8246	Scatola RT400-2V	1
2	8185	Ruota dentata Z=55	1
3	8214	Mezzo Ø55	1
4	8304	Destanziale	1
5	8196	Cuscinetto 60x16	2
6	8253	Anello di ten. 80/130/10	1
7	8195	Seegel I 125	1
8	8197	Anello di ten. 80/125/13	1
9	8233	Pignone di rinvio Z=12	1
10	8239	Ruota dentata Z=50	1
11	8241	Innesto scorrevole	1
12	8242	Boccola dentata	1
13	8318	Ruota dentata Z=33	1
14	8342	Cuscinetto 6208	3
15	3435	Seegel I 80	4
16	8243	Tappo Ø80 sp 10	3
17	8670-2	Corona conica Z=43	1
18	8317	Pignone di rinvio Z=15	1
19	3396	Chavetta 8x7x25	1
20	8586	Cuscinetto 6306	1
21	3433	Seegel I 62	1
22	8626	Tappo Ø62 sp 10	1
23	8670-1	Pignone 7x28	1
24	1538	Cuscinetto 60x0	1
25	3428	Seegel E 50	1
26	8671	Guarnizione x motore	1
27	1479	Tappo Ø1" Gas	1
28	1831	Spal. lit. olio Ø1" Gas	1
29	8243	Forcella	1
30	3948	Pattino x forcella	2
31	8353	OR 3110	1
32	8324	Molla x leva	1
33	8323-1	I res. x forcella	1
34	8352	Dado M8-IG	1
35	8351	Vite TE M8x4-8G	1
36	8339	Spina Cilindrica Ø12x60	1
37	8245	Guarnizione	1
38	8244	Coperchio	1
39	3285	Vite TE M8x20-8G	8
40	8175	Tappo albero Ø1" Gas	1
41	8365	Vite TCEI M10x16-8G	1
42	8254	Spina Cilindrica 8x25	2

TWO SPEED GEARBOX

0 NEUTRAL

1 LOW (NORMAL USE)

2 HIGH (LIGHT/HIGH VOLUME)

Note: When changing gears, use the red manual over-ride knob (on the control valve) to slowly turn the floor belt while gently moving the gear lever across.

Optional Roll-Over Cover

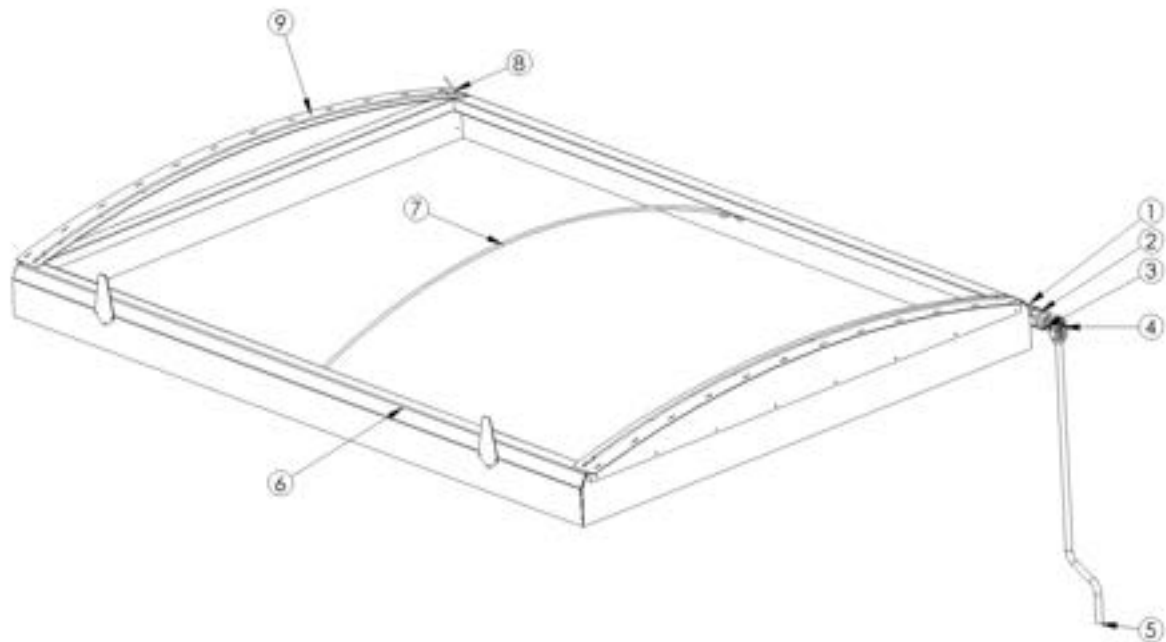

Item	Part Number	Description	Quantity
1	SSAE30x30x3	Stainless Angle	
2	AL34049	Aluminum Tube	
3	135-4519	Male Plug	1
4	GBBA165002	Universal Joint	1
5	135-0681-1	Extending Handle	1
6	AL6595	Aluminum "P" Extrusion	
7	RODFIB12	Fiberglass rod	
8	135-4520	Female plug	1
9	Fert cover ends kit V3	End panels	2

NOTE: Certain parts will vary in length from model to model, please enquire before ordering

Optional Lights

Lights may be easily retrofitted into the pre-existing guards on the rear of the machine. P/N – LIGHTLED-LH and LIGHTLED-RH should be ordered.

Banding Attachment – Single Side

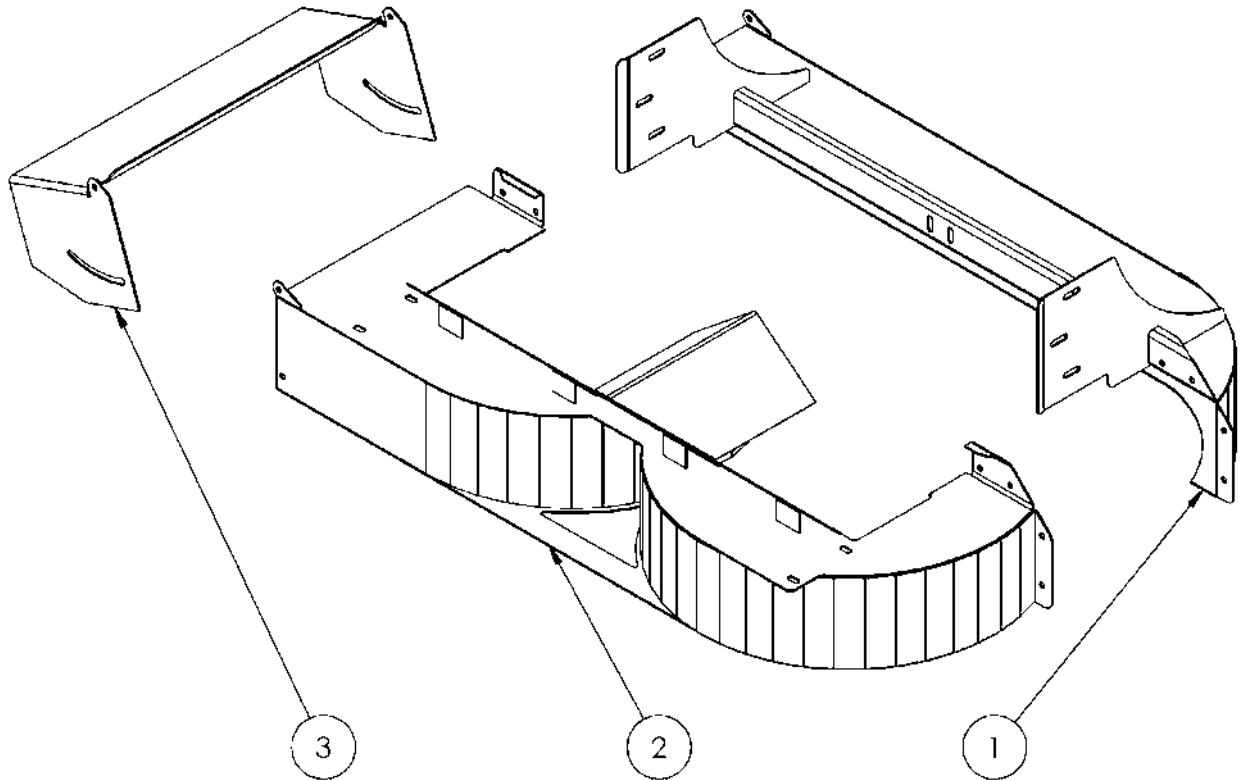

ITEM NO.	PART NUMBER	DESCRIPTION	QTY.
1	13482	OUTER DEFLECTOR	1
2	13483	INNER DEFLECTOR	1
3	11276-9	DEFLECTOR	1

Banding Attachment – Dual Side

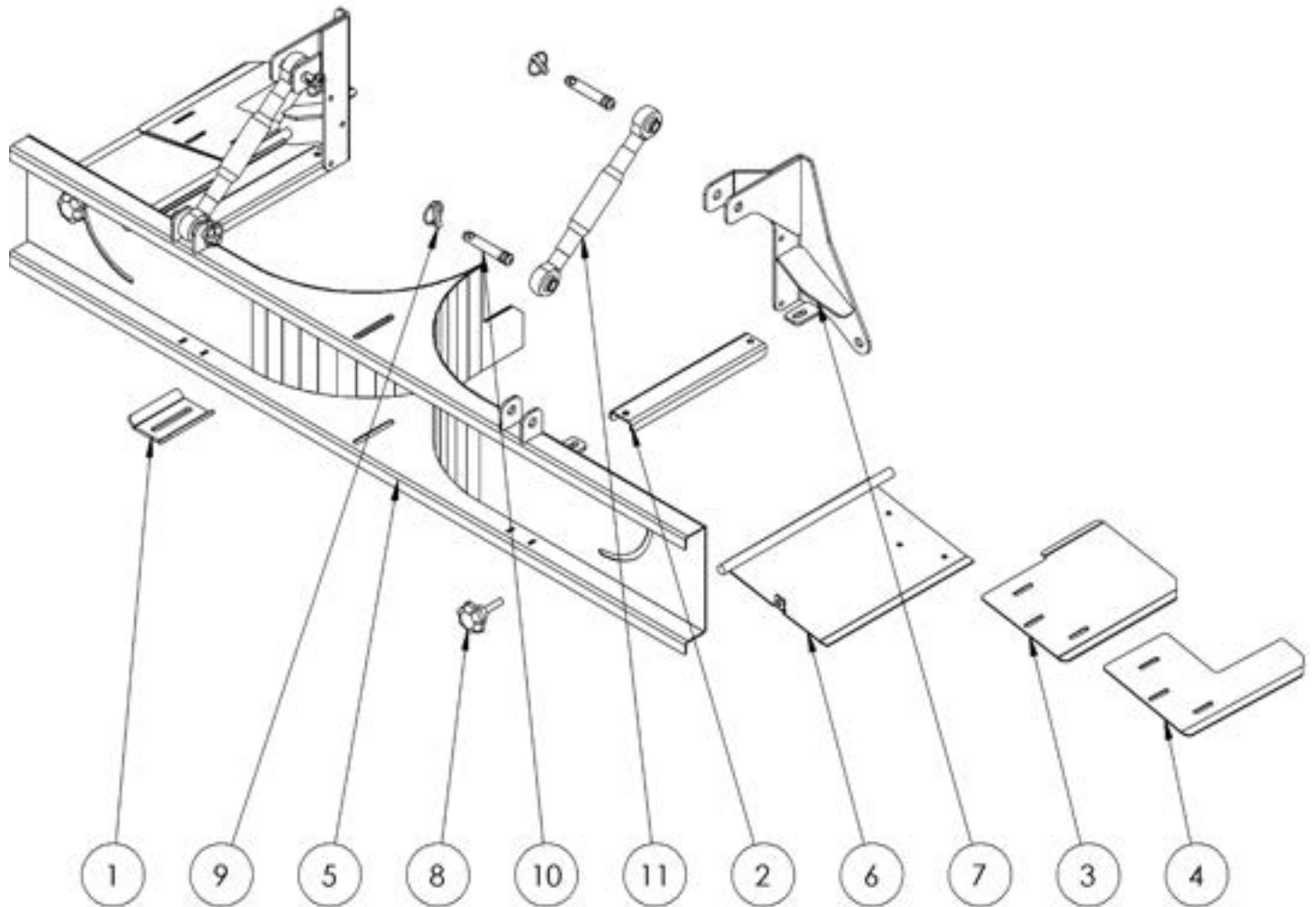

ITEM NO.	PART NUMBER	DESCRIPTION	QTY.
1	10453-1	RHS Clamp	1
2	10453-2	slide brace	2
3	10453-6	Flap extension	2
4	10453-7	Flap extension	2
5	10454	rear deflector assembly	1
6	10455	Side deflector assembly	2
7	10456	Side deflector pivot mount	2
8	comac 2744	M12 stainless knob	2
9	FP10.013	LINCH PIN 11mm	4
10	FP10.314	Top link pin CAT1 95mm	4
11	S15314	CAT 1 toplink 345-470mm	2

Depending on machine, assembly only requires a pair of either Item 3 OR 4

3T/Orchard Cross Conveyor Attachment

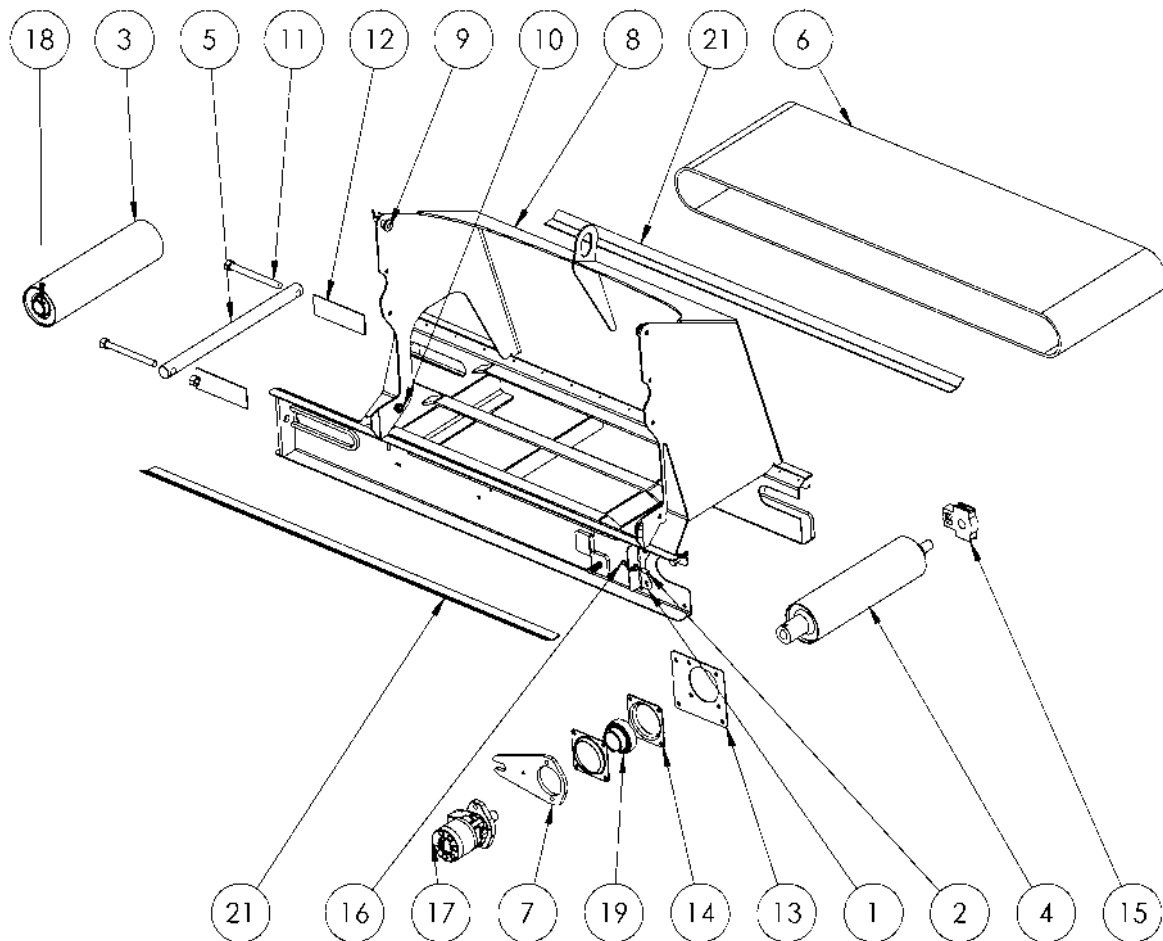

ITEM NO.	PART NUMBER	DESCRIPTION	QTY.
1	10476	FERT CONV. PROX SENSOR MOUNT	1
2	10479	FERT CROSS CONV SENSOR PICKUP	1
3	10672	IDLE ROLLER	1
4	10673	DRIVE ROLLER	1
5	10674	IDLER SHAFT	1
6	10676	CONVEYOR BELT	1
7	11294	MOTOR MOUNT	1
8	11435	CROSS CONV WELDED ASSEMBLY	1
9	11583	TOP HAT	2
10	11584	BOTTOM HAT	2
11	596-1004	ADJUSTER SCREW	3
12	780-2006	ADJUSTER NUT SLIDE	2
13	BUC-047	CONVEYOR BEARING MOUNT	1
14	BUC-048	CONVEYOR BEARING SHELL	2
15	HSGTU505	BEARING HOUSING, TAKE UP, 25MM	1
16	11654	E2A-S12KS04-M1-C1, SPEED SENSOR	1
17	HYM65-PT	PARKER TE065	1
18	BRGYAR207	BEARING INSERT, 35MM	2
19	BRGYAR210-2F	BEARING INSERT, 50MM	1
21	13687	SEALING STRIP	2

3T/Orchard Dual Side Cross Conveyor Attachment

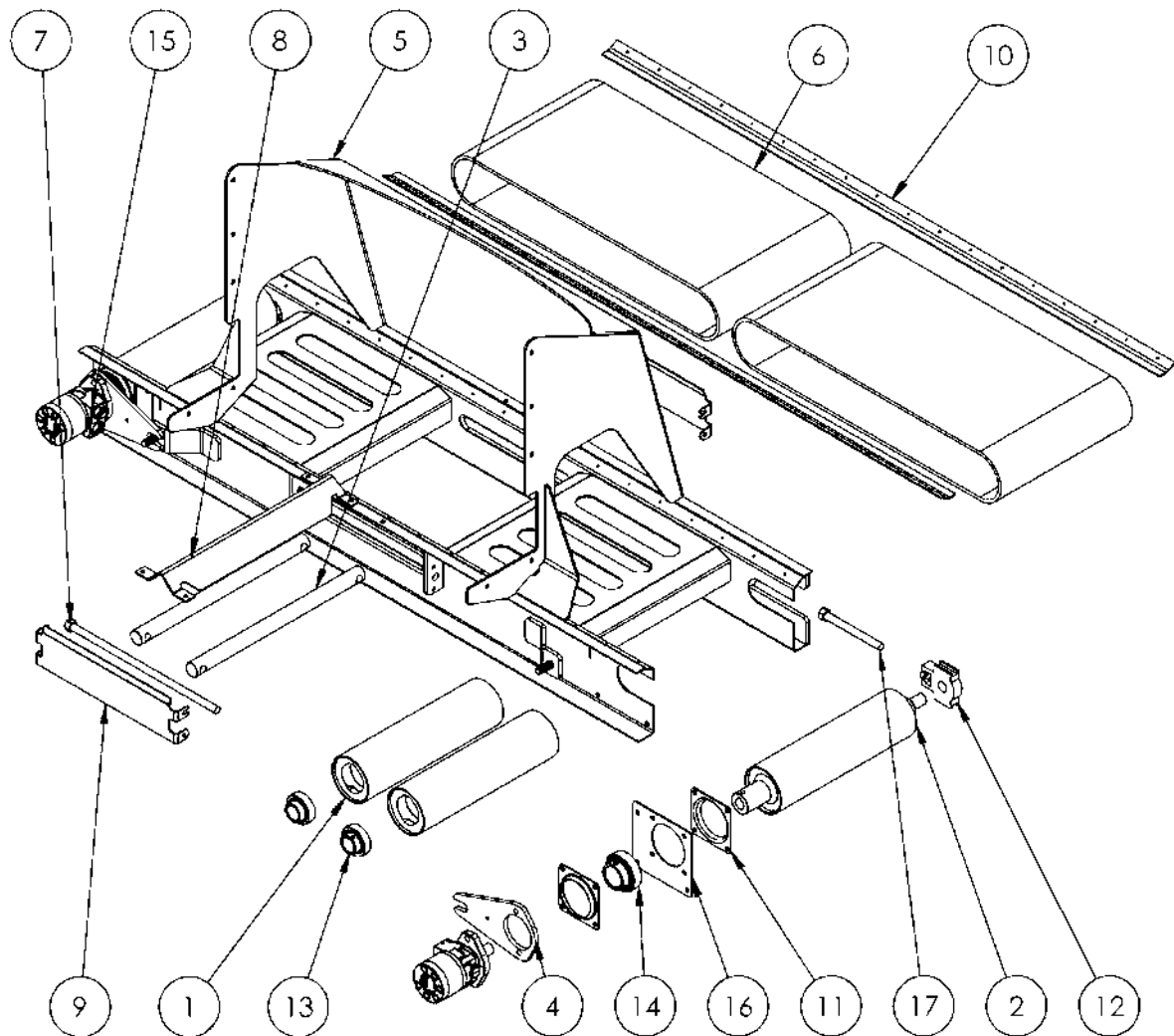

ITEM NO.	PART NUMBER	DESCRIPTION	QTY.
1	10672 Idler roller	Idler roller	2
2	10673 Drive roller	Drive roller	2
3	10674 Idler shaft	Idler shaft	2
4	11294	MOTOR MOUNT	2
5	11438 Fert Cross Conveyor welded assy		1
6	11439	CONVEYOR BELT	2
7	11440	Adjuster Screw	2
8	11441	Centre Deflector	1
9	11442	Adjuster Cover	2
10	60X3.2 UMPY	Conveyor Seal Strip	2
11	BUC-048	CONVEYOR BEARING SHELL	4
12	HSGTU505	BEARING HOUSING, TAKE UP	2
13	BRGYAR 207	BEARING INSERT, 35MM	4
14	BRGYAR 210-2F	BEARING INSERT, 50MM	2
15	HYM65-PT	PARKER TE065	2
16	BUC-047	CONVEYOR BEARING MOUNT	2
17	596-1004	Adjuster Screw	2

4T to 15T Cross Conveyor Attachment

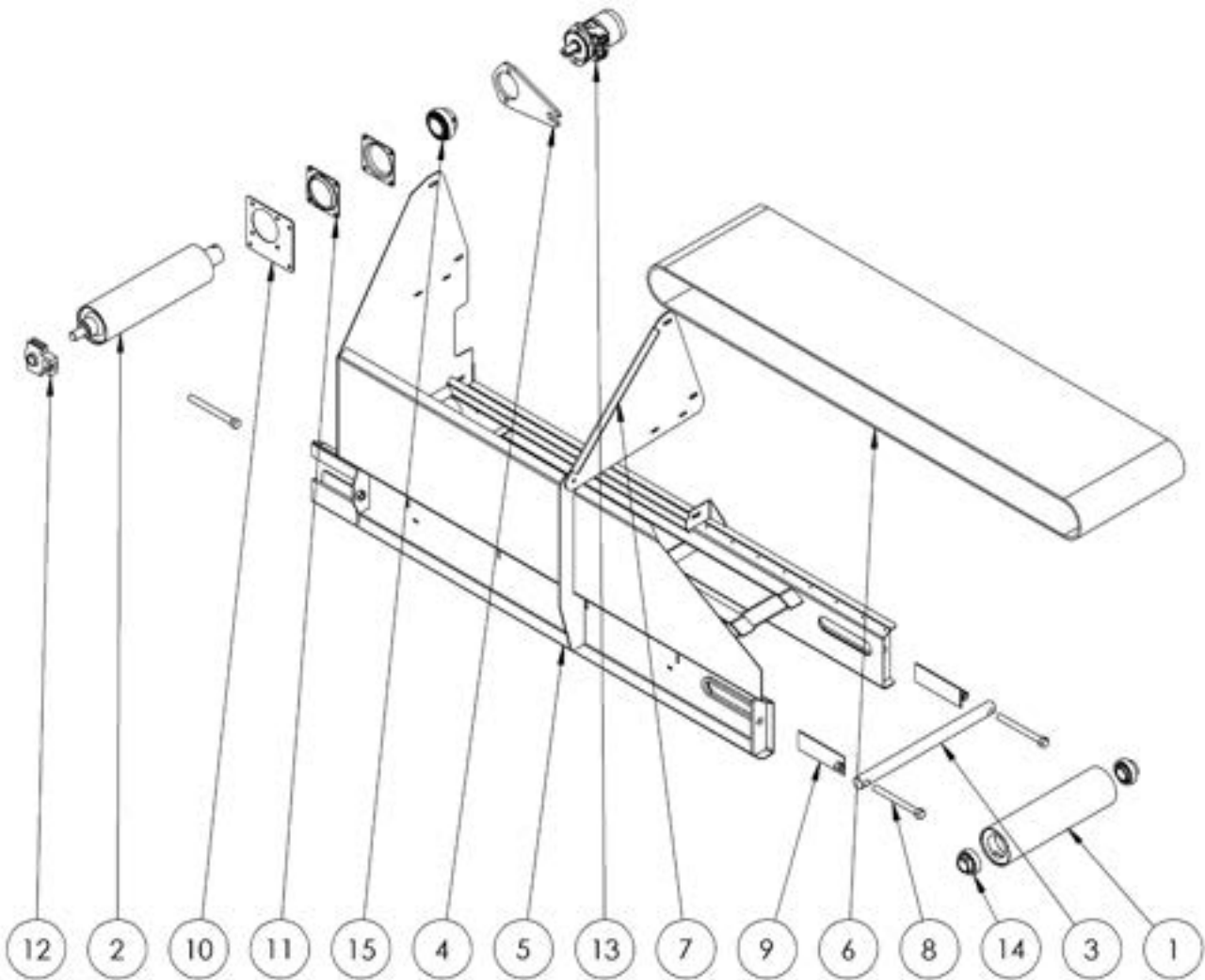

ITEM NO.	PART NUMBER	DESCRIPTION	QTY.
1	10672	IDLE ROLLER	1
2	10673	DRIVER ROLLER	1
3	10674	IDLER SHAFT	1
4	10675	MOTOR MOUNT	1
5	10855	CROSS CONVEYOR WELDED ASSEMBLY	1
6	10856	CONVEYOR BELT	1
7	10857	MOTOR MOUNT	1
8	596-1004	ADJUSTER SCREW	1
9	780-2006	ADJUSTER SLIDE	3
10	BUC-047	CONVEYOR BEARING MOUNT	1
11	BUC-048	CONVEYOR BEARING SHELL	2
12	HSGTU505	BEARING HOUSING, TAKE UP, 25MM	1
13	HYM65-PT	PARKER TE065	1
14	BRGYAR207	BEARING INSERT, 35MM	2
15	BRHYAR210-2F	BEARING INSERT, 50MM	1

Farmscan Section



Table Of Contents

SCREEN OVERVIEW	68
<i>Tab 1 – Main Operating Screen</i>	68
<i>Tab 2 – Spinner Control</i>	69
<i>Tab 3 – GPS Mapping</i>	70
<i>Tab 4 – Loadcells (Optional)</i>	71
SETTING MAIN PARAMETERS.....	72
<i>Driving centers</i>	72
<i>Gate height</i>	73
<i>Spread rate</i>	74
SPREAD RATE INDICATION ARROWS	75
HECTARE METER.....	76
PRODUCT DENSITY	77
ALTERING FLOW FACTOR.....	78
SPINNER CONTROL	79
SPINNER SPEED INDICATION ARROWS	80
SPINNER CALIBRATION	81
FLOW FACTOR CALIBRATION	83
JOB CREATION	86
USB DRIVES.....	87
OPERATION.....	88
CHECKING SOFTWARE VERSION	89
UPDATING SOFTWARE VERSION	90
EXPORTING SETTINGS TO USB	91
IMPORTING SETTINGS FROM USB	92
ZEROING BIN WEIGHT	93
USING GPS SPEED SOURCE	94
EXPORT GPS MAPPING TO USB	95
CLEARING GPS MAPPING.....	96
ENABLE PRIME MODE.....	97
SETTING SPINNER TURBO AND HALF SPEEDS	98
SECTION CONTROL	100
<i>Setup</i>	100
<i>Screen Setup</i>	105
<i>To Remove Spinner Width Controller from Screen</i>	106
<i>Operation</i>	107
HEADLAND CONTROL.....	108
<i>Setup</i>	108
<i>GPS Setup</i>	109
<i>Adjustable Settings</i>	112
<i>Screen Setup</i>	115
<i>Operation</i>	116
MONITOR LED STATUS LIGHTS.....	116
TROUBLESHOOTING	118

Screen Overview

Tab 1 – Main Operating Screen - 7000 Series



7000-Plus Series

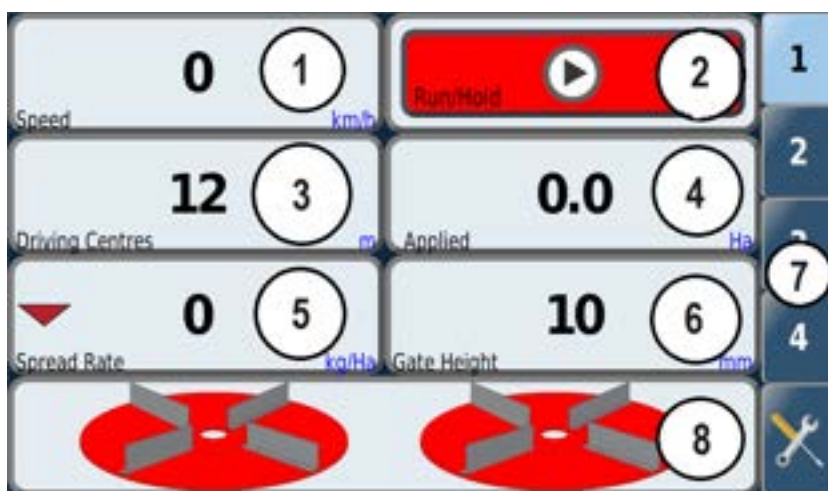

1. Ground speed, (Km/h) driven by wheel sensor or optional GPS antennae
2. Run/Hold button, turns the floor drive off/on
3. Driving centers, or adjacent pass to pass centers
4. Hectare meter, counts hectares covered whilst run/hold is active. Use is covered later on in guide
5. Spread Rate, (Kg/Ha) desired application rate of product. Or the actual spreading rate whilst Run/Hold is active, this will be covered in more depth later on in this guide.
6. Gate Height, (mm) this is the height that the rear door has been manually adjusted to.
7. Tab selector, buttons to change from tab to tab or enter settings.
8. Spinner On/Off controls (7000-Plus screen only)

Tab 2 – Spinner Control

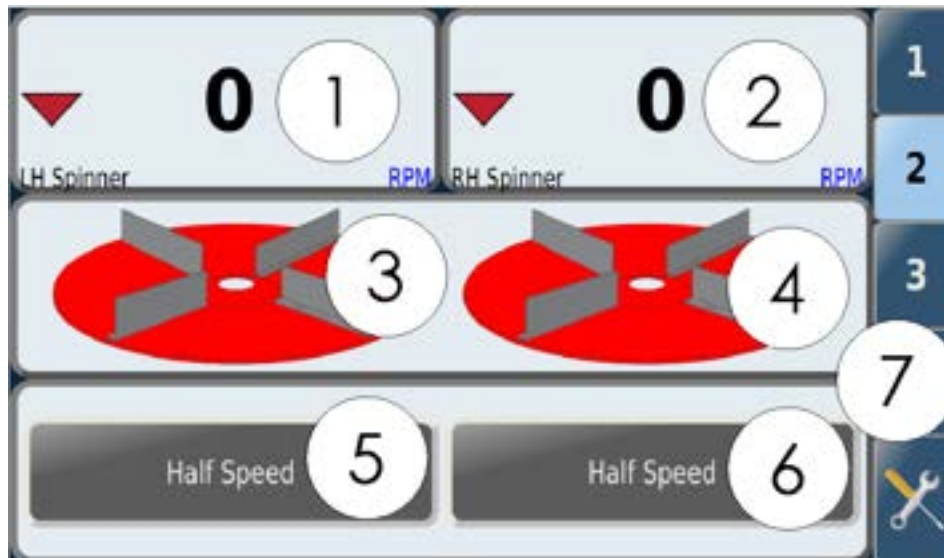

NB: Spinner left/right is whilst sitting on tractor seat looking forward.

1. Left hand spinner RPM readout and setting
2. Right hand spinner RPM readout and setting
3. LH spinner on/off (Red is off, green is on)
4. RH spinner on/off (Red is off, green is on)
5. LH spinner quick speed sets
6. RH spinner quick speed sets
7. Tab selector, buttons to change from tab to tab or enter settings.

Tab 3 – GPS Mapping

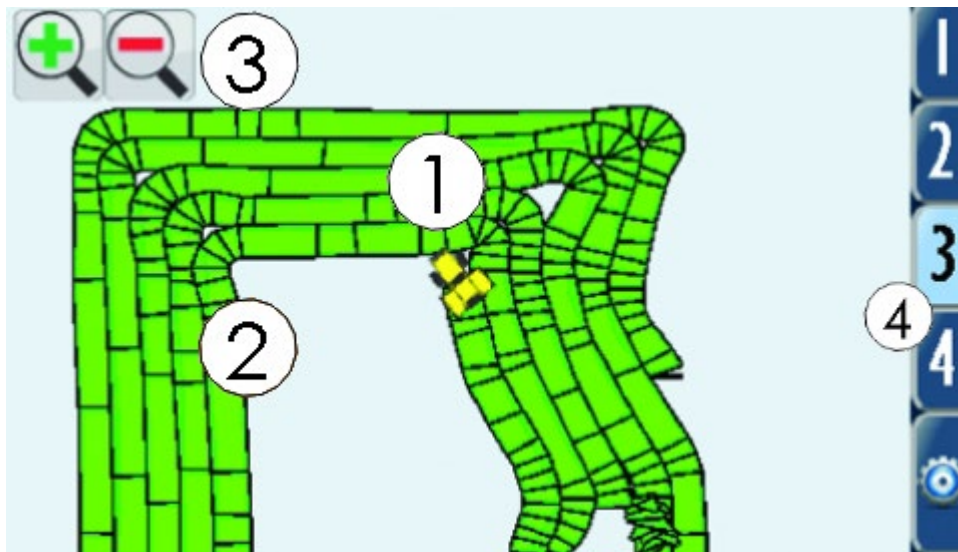

1. Tractor icon, shows location of tractor.
2. Coverage, green = covered, white = uncovered. Each segment indicated a speed or direction change.
3. Zoom in/out
4. Tab selector, buttons to change from tab to tab or enter settings

The width of the coverage is determined by the “Driving centers” setting

NOTE: GPS mapping is only able to used when a GPS antennae is connected to the unit

Tab 4 – Loadcells (Optional)

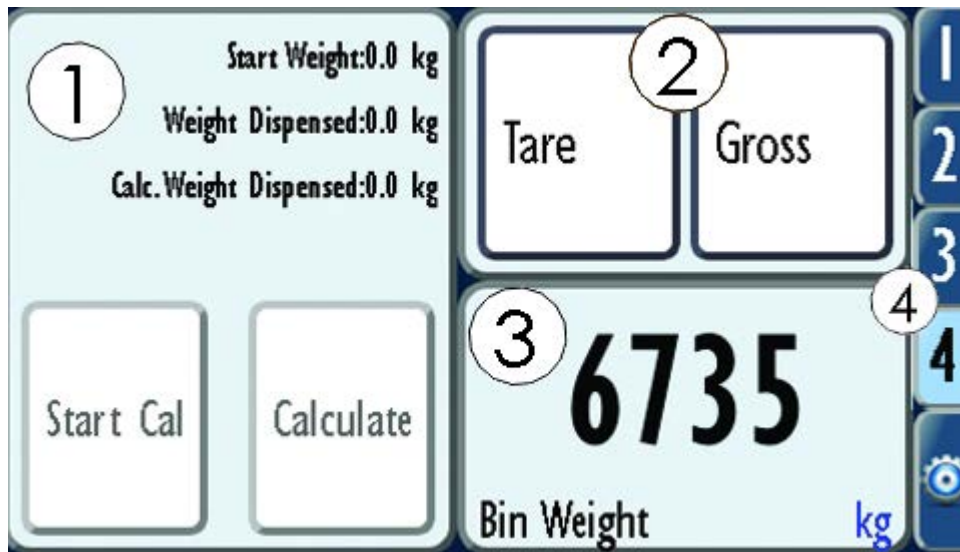

1. Flow factor calibration
2. Tare / Gross buttons
3. Current load cell reading
4. Tab selector, buttons to change from tab to tab or enter settings

The operation of the flow factor calibration will be covered in-depth later on in this guide.

Setting Main Parameters

Driving centers

“Driving centers” is the distance from the center of the tractors 1st pass wheelings to the center of the 2nd pass wheelings. As shown by diagram below.

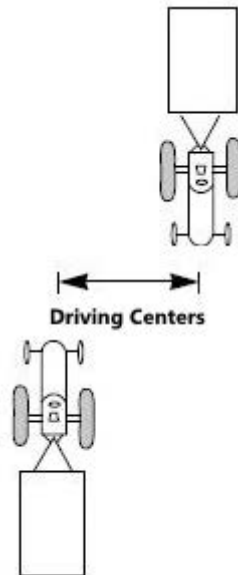

To change the driving centers follow the below steps.

1. Find the driving centers button (located on tab 1)



2. Tap the button to enter settings mode, use +/- arrows to change the driving centers in 1m increments



3. Tap the button again to exit settings mode, new driving center is automatically saved.



Gate height

Gate height is the height of the opening the rear gate has been manually set to. The recommended height is obtained by reading the chart either on the rear of the machine or in this guide. Note the height is from the belt to the gate, not from the top of the cleats.

To change the gate height follow the below steps.

1. Obtain the recommended gate height from the gate chart
2. Set gate to recommended height, either with manual lever or hydraulic ram

3. Find the gate height button (located on tab 1)



4. Tap the button to enter settings mode, use +/- arrows to change the gate height in 5mm increments



5. Tap the button again to exit settings mode, new gate height is automatically saved



Alternatively, if the operator wishes to change the gate height by a large amount, it will be faster to change the gate height by going:

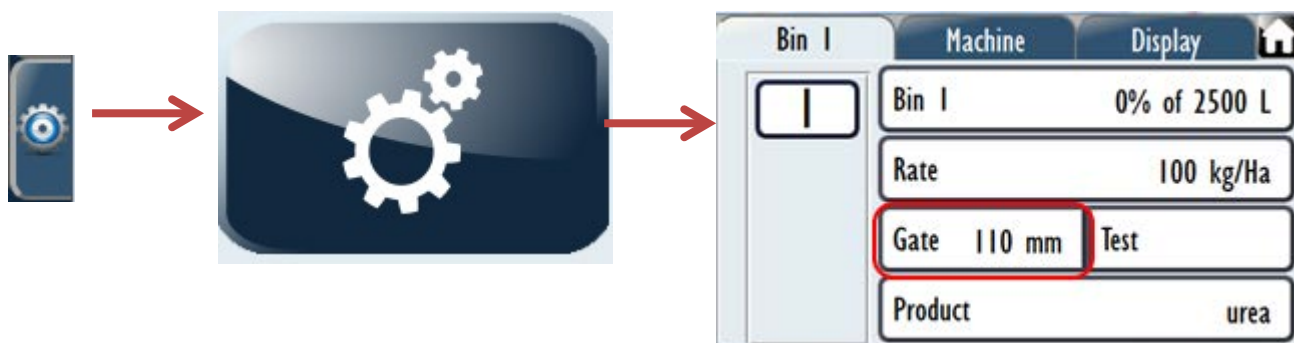

Select gate height, type in required height, and tick to save.

Spread rate

Spread rate is the desired rate of application in Kg/Ha

To change the spread rate follow the below steps,

1. Find the spread rate button (located on tab 1)
It is important to note that this button provides live feedback of the actual rate, therefore it will be 0 if the run/hold button is off.



2. Tap the button to enter settings mode, use +/- arrows to change spread rate in 10kg increments



3. Tap the button again to exit settings mode, new spread rate is automatically saved

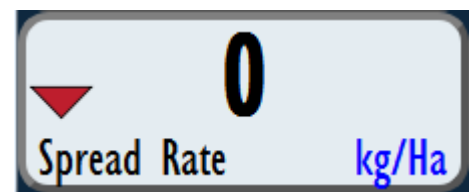

Alternatively, if the operator wishes to change the spread rate by a large amount, it will be faster to change the spread rate by going:



Select Belt 1 Rate, type in required rate, and tick to save.

Spread rate indication arrows

The spread rate has a visual indicator function that allows the operator to easily tell if the spread rate is close to their desired set rate.

If the spread rate is within 10% +/- of the desired rate a green bar will display next to the spread rate

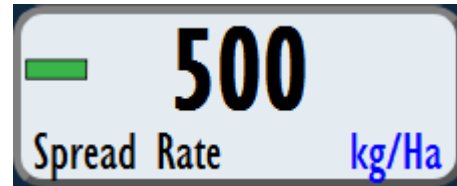

If the spread rate is lower than 90% of the desired rate, a downwards pointing red arrow will be displayed. Possible remedies are:

- Decrease forward speed
- Increase gate height
- Decrease spread rate

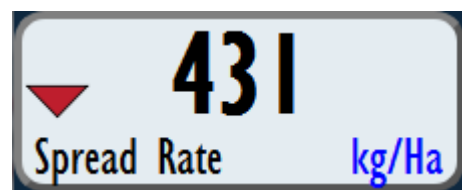

If the spread rate is constantly fluctuating from a high to a low rate (the belt will also visibly speed up and slow down) it is likely that the spread rate is too low for the settings, possible remedies are:

- Reduce gate height
- Increase forward speed
- Increase spread rate.

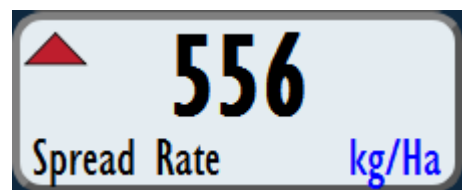

Hectare meter

The area meter provides an easily resettable tally of the hectares covered by the fertilizer whilst the run/hold switch is in run mode. It is linked to the driving centers setting.

If the user wishes to reset this meter, follow the below steps

1. Locate the hectare meter tile (located on tab 1)

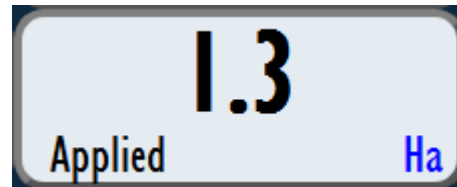

2. Tap the button to enter reset mode, a reset arrow will appear.



3. Press reset arrow, a tick and cross will appear

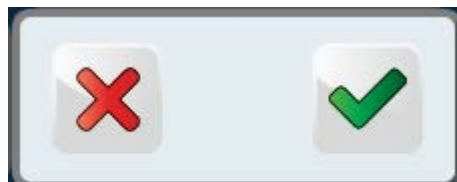

4. Press tick arrow to confirm reset (or cross to cancel) Hectare counter has now been reset.



Product density

The first step in setting product density is to create a product that the density will correspond to.

1. Tap Settings Icon



2. Tap Setup Menu Icon



3. Select Product Tab



4. Select Product



On selecting product, a list of loaded products will appear. Select the product to modify. In this menu it is possible to add a new product by tapping the green plus button, or removing existing products by pressing the red minus button.



5. Select Details



6. Select Bulk Density and set value

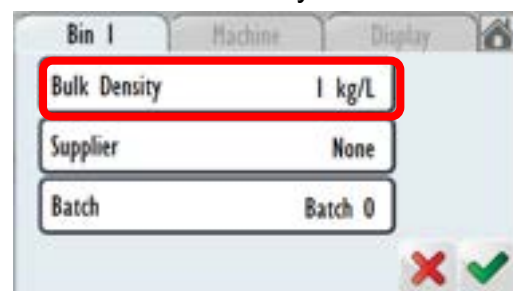

Altering Flow Factor

This calibration process fine tunes the system to take into account how different types of product flow through the spreader's rear door. This can be altered if the user finds that the machine is consistently spreading heavy or light.

Heavy rate example:

Machine should have spread 1000kg but has spread 1100kg – Decrease the existing flow factor by a value of 10% i.e. $(\text{old flow factor} / 100) \times 90$

Light rate example:

Machine should have spread 1000kg but has spread 900kg – Increase the existing flow factor by a value of 10% i.e. $(\text{old flow factor}/100) \times 110$

1. Tap Settings Icon



2. Tap Setup Menu Icon



3. Select Product Tab

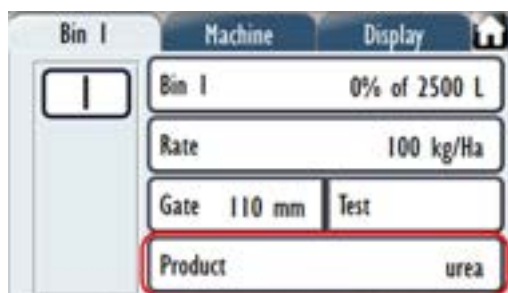

5. Select Calibrate

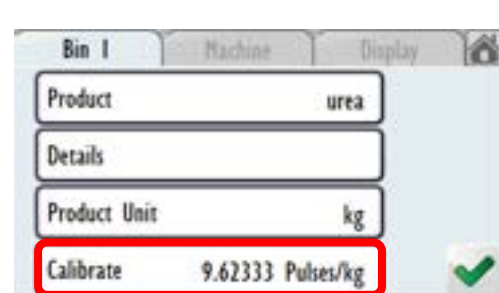

6. Select the Flow Factor button

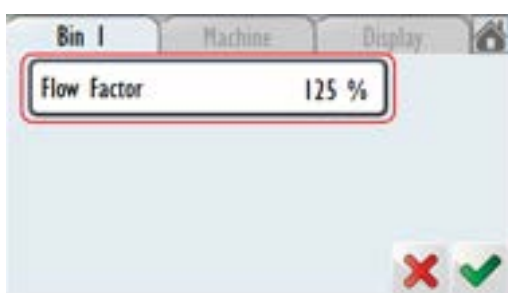

Giltrap Engineering recommends a Flow Factor of 125% as a starting point for the majority of products.

Spinner control

When the screen is turned on the spinners are turned off by default and need to be turned on. This is a safety feature so that the spinners are not inadvertently running. To turn spinners on, press the spinner icon to turn them to green. The spinner will then increase in speed to the desired set speed.



To change spinner speed follow the below steps:

NOTE: Spinner speeds can be adjusted whilst spinners are running.

1. Select relevant spinner RPM button (left or right, both located on tab 2)

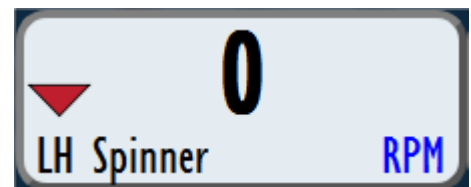

2. Tap the button to enter settings mode, use +/- arrows to change the spinner set speed in 50 RPM increments



3. Tap the button again to exit settings mode, new spinner speed is automatically saved



NOTE: The spinner RPM button provides a live readout of the spinner speed so will be zero if the spinner is turned off.

Spinner speed indication arrows

The spinner speed has a visual indicator similar to the spread rate function that allows the operator to easily tell if the speed is close to their desired set speed.

NOTE: SPINNERS SHOULD NOT BE OPERATED ABOVE A MAX OF 1100RPM

If the spinner speed is within 10% of the desired speed a green bar will display next to the spinner RPM

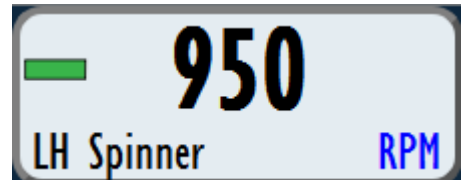

If the spinner speed is lower than 90% of the desired speed, a downwards pointing red arrow will be displayed. Possible remedies are:

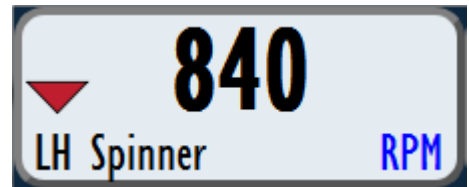

- Increase oil flow from tractor
- Lower the speed setting to an achievable rate

If the spinner speed is higher than 110% of the desired speed, an upwards pointing red arrow will be displayed. Possible remedies are:



- Reduce oil flow from tractor

Spinner Calibration

Spinner calibration is recommended to be done with the tractor running and hydraulics set to approximately 60 litres per minute.

1) Tap Settings Icon



2) Tap Setup Menu Icon



3) Tap Machine

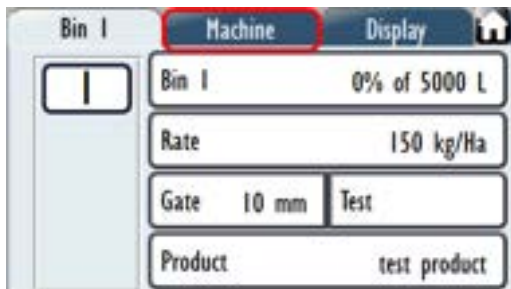

4) Tap Control



5) Tap Spinner Setup

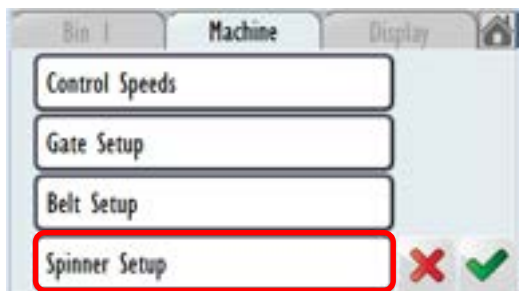

6) Tap Spinner 1 Setup



3. Tap Spinner Motor Setup

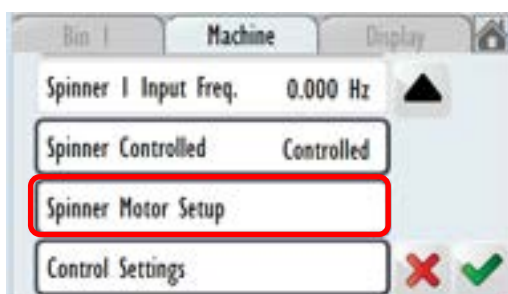

8) Tap Auto Calibrate

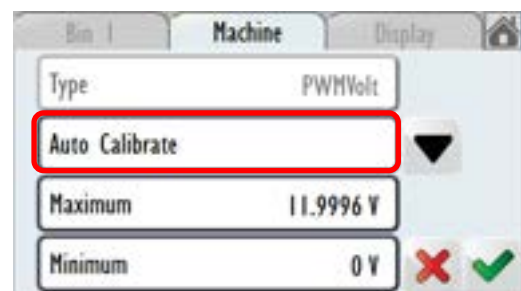

9) Tap Start

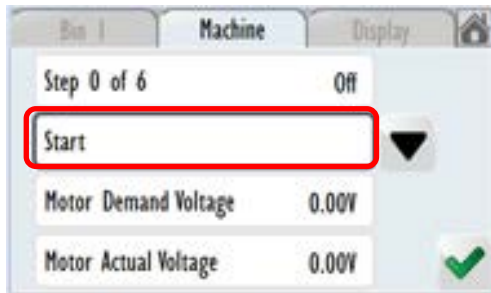

Calibration should take approximately 10-12 minutes to complete.

Then tick back out to (Spinner 2 setup)

Repeat steps 6-9 for spinner 2 calibration.

If calibration takes longer than 15 minutes, stop and restart – highlighted start button opposite changes to stop once calibration has started.

Flow factor calibration

If the machine has been fitted with the optional Load Cell package then it is possible to calibrate the spread rate based on real time data from the Load Cells by following the steps below. Tab 4 is preset to show load cell data.

1. When driving, the “Start Cal” and “Calculate” buttons are greyed out, this is due to the bin weight fluctuating from vibrations.

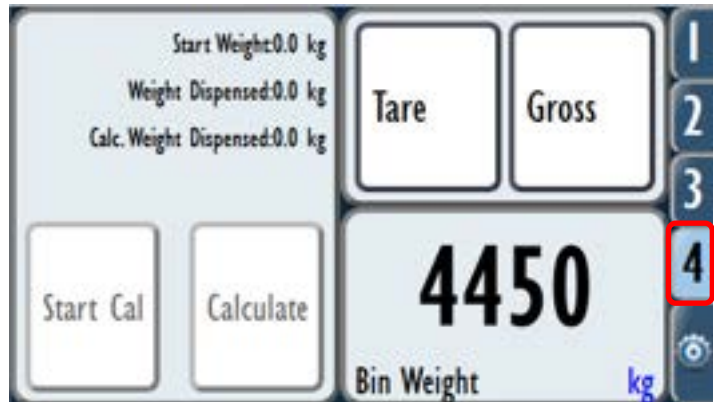

2. When the machine is brought to a rest a 5 second countdown will begin once the load cell reading is steady.

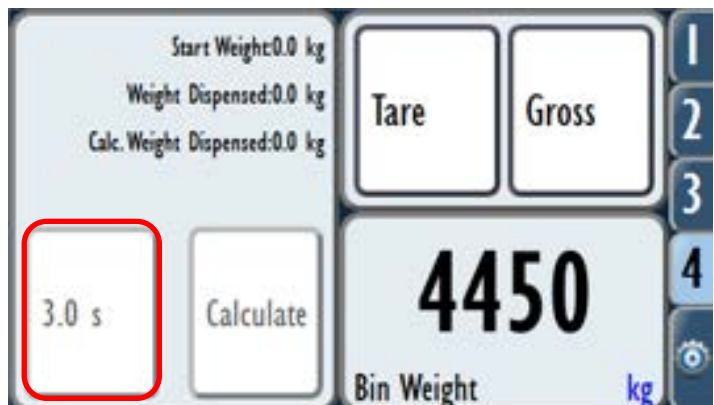

3. After the 5 second timer is completed the “Start Cal” button will be available for selection

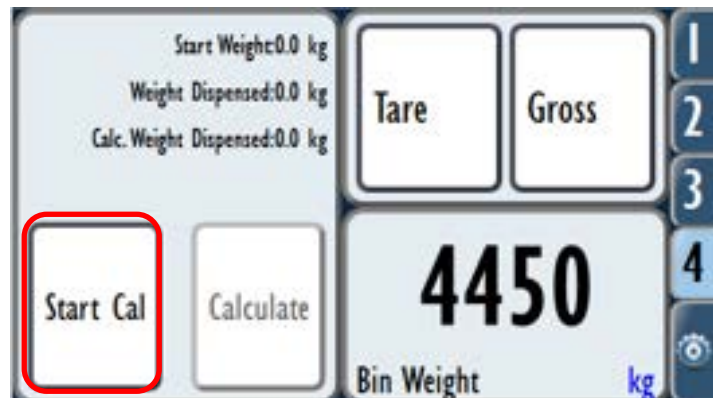

4. When “Start Cal” has been pressed the bin weight at time of calibration start is recorded. SPREADING MAY NOW COMMENCE

The “Reset Cal” button also takes the place of “Start Cal” this allows the user to restart the process (after allowing 5 second countdown)



5. With the calibration in progress and the machine in Run mode the “Weight dispensed” and “Calc. Weight Dispensed” values will increase. Weight dispensed is based on the load cell reading, and Calc. Weight is the amount that the spreader should have dispensed.

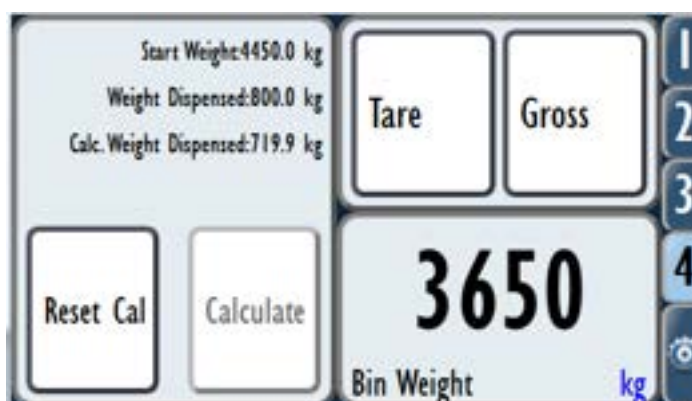

In order to allow a calibration to be completed the user must dispense 0.5% of the bin volume at a minimum, this will vary due to product density, but will be somewhere in the region of 25-65kg dependent on model size. It is recommended that the user runs the calibration for longer than this to gain a better average.

6. After an appropriate amount has been dispensed and the machine has been brought to a stop to allow the load cells to settle, a 5 second countdown will appear over the “Calculate” button



7. After the 5 second timer is completed the “Calculate” button will be available for selection

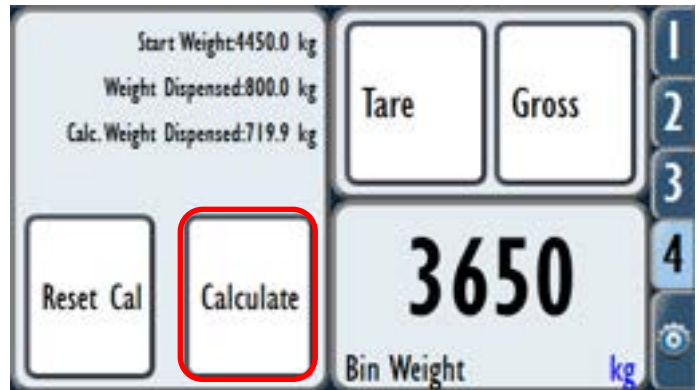

8. When the “Calculate” button has been pressed a screen will appear informing the user of the calibration results.

In this example the actual weight loss is 10% less than the calculated weight loss. Therefore the flow factor has been adjusted by 10%

Press “Update” to accept new flow factor

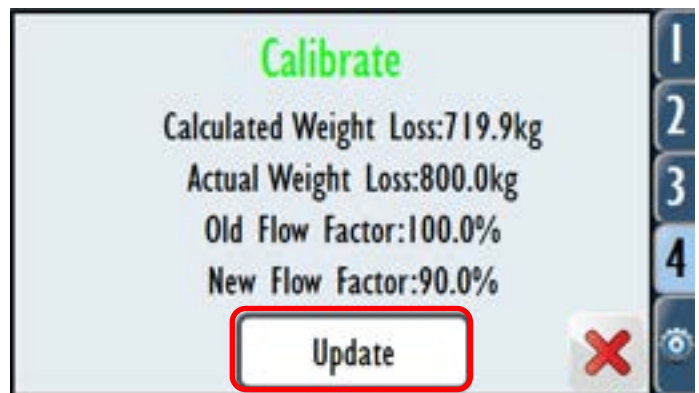

The user may now continue spreading; calibration may be carried out as many times as desired.

NOTE: This calibration is linked to the Product selected in Bin 1 settings

Job Creation

Jobs are used to record spreading data

1. Tap Settings



2. Tap Job Menu Icon



3. There are three jobs set up from factory:

- A 'Master Job' – which saves all the total usage data of the machine – this job cannot be removed.

- A 'Blank Job' set up and ticked 'Active.' This contains the factory settings and MUST be here.

- 'Job 1' can be used as a standard job, edited, deleted, renamed if required. A 'standard type' job must be ticked active at all times when using the machine.

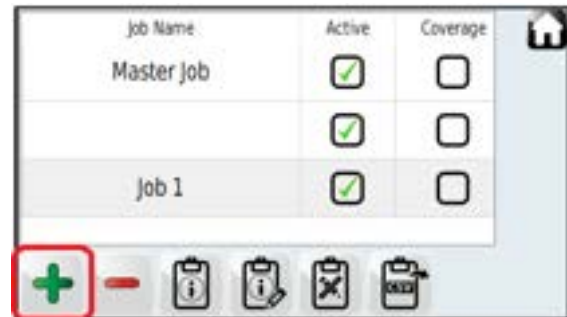

4. To create a new job, tap the 'Add job button(+). Enter a new Job name. Accept to save

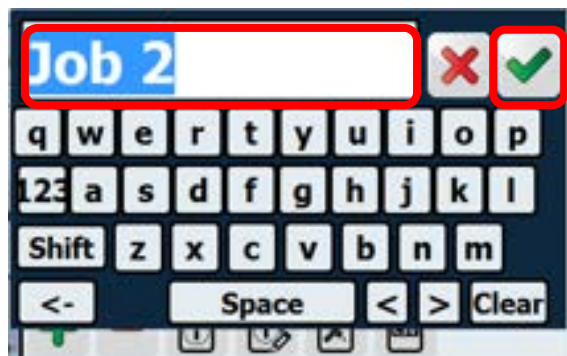

5. Ensure the new job is ticked 'Active.' If GPS is fitted, Coverage also needs to be ticked. Note GPS coverage can only be ticked on one job at a time.



USB Drives

There are two USB drives included with the Giltrap controller, see below for their uses.



The blue USB is for user data such as the transfer of job records or for saving custom settings.
NB: Giltrap only recommends the use of high quality USB drives.



The red USB is pre-recorded with the base settings from factory. This drive should be kept in a safe place as it allows the controller to be reset to standard in the case of error.
DO NOT OVERWRITE

Operation

When the 4 main parameters (Spread rate / Driving Centers / Gate Height / Product density) are loaded and spinners have been set to the desired RPM the machine is ready to spread product.

- Engage tractor hydraulics to provide oil flow to the spreader. It is recommended to have oil flow of 60-65 litres a minute. The machine will operate at lower flows but the maximum spinner speed will be affected.
- On screen two, turn on Spinners. Allow them to come up to operating rpm
- Begin travelling forward (the machine will not move the belt whilst stationary as belt speed is relative to forward speed)
- Turn run/hold button on (It will change from red to green) The LED light on the side of the screen will change from steady (in hold mode) to flashing (in run mode)
- Commence spreading; the run/hold button can be used to pause the spreader at headlands etc.

7000 Series Screen



7000-Plus Series Screen



Checking software version

1. Tap Settings Icon



2. Tap Maintenance Menu Icon



3. Tap About Button



4. Check version number against software USB.



If numbers match no further requirements, if numbers on screen is lower, update software by following method. If number on screen is higher, software is likely superseded by Farmscan. CONTACT FARMSCAN TO CONFIRM.

Updating software version

1. Tap Settings Icon



2. Tap Maintenance Menu Icon



3. Tap "System" Button



4. Insert USB with latest software into screen and press "update" button



5. Press "Begin Update" to begin. When the update reaches 100% the screen will reboot. This reboot will take longer than usual and will cause a blank green screen. Once the reboot is complete, ensure screen stays of for a few minutes.

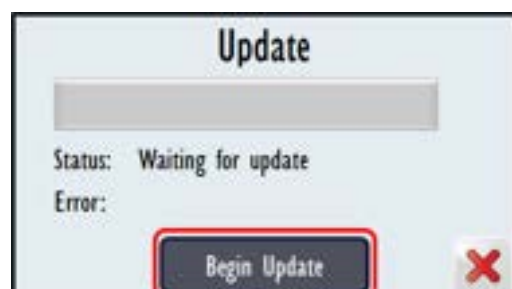

Exporting Settings to USB

If monitor layouts and settings are customized and changed from factory defaults, they should be backed up on the supplied BLUE USB.

1. Turn on screen and insert USB to export settings onto.
2. Tap Settings Icon



3. Tap Maintenance Menu Icon



4. Tap "System" Button



5. Tap "Reset" Button



6. Scroll Down and Tap "Export Settings to USB"

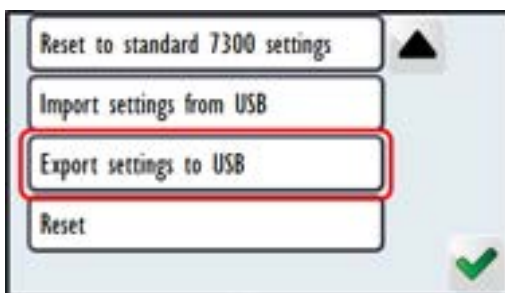

7. Tap "Ok"



This process should be done as often as settings and layouts are customized.

Importing Settings from USB

1. Turn on screen and insert USB with appropriate .bin file.

NOTE: 7000 Series and 7000-Plus Series screens require different .bin files. Ensure the correct .bin file for your machine is used.

2. Tap Settings Icon



3. Tap Maintenance Menu Icon



4. Tap "System" Button



5. Tap "Reset" Button



6. Tap Import Settings from USB

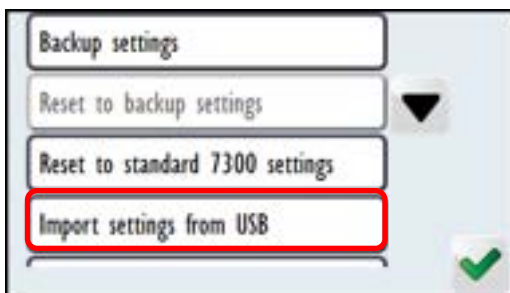

7. Tap "Ok"



8. Run machine to check upload of settings was successful.

Zeroing Bin Weight

If the weight readings on the monitor are fluctuating during use or when stationary even after 'Taring', the bin must be emptied and bin weight 'zeroed'.

1. Tap Settings Icon



2. Tap Setup Menu Icon



3. Tap Bin 1

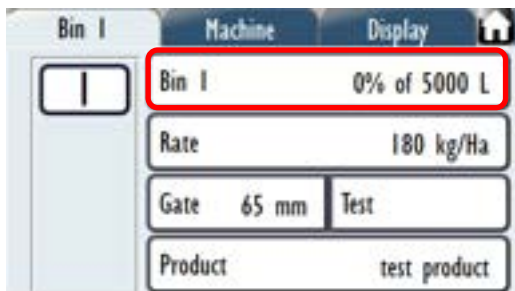

4. Scroll Down and tap Load Cell Configuration

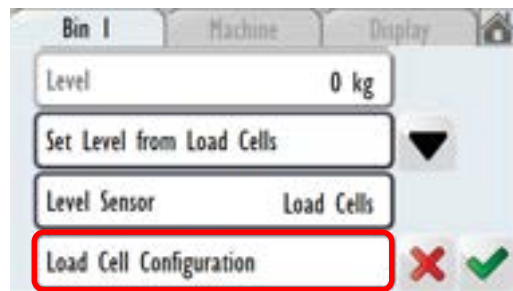

5. Tap Zero Bin Weight

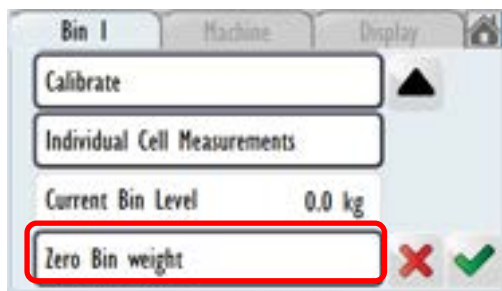

Using GPS Speed Source

If GPS is fitted, it can be used to measure speed instead of the wheel speed sensor.

1. Tap Settings Icon



2. Tap Setup Menu Icon



3. Tap "Machine"

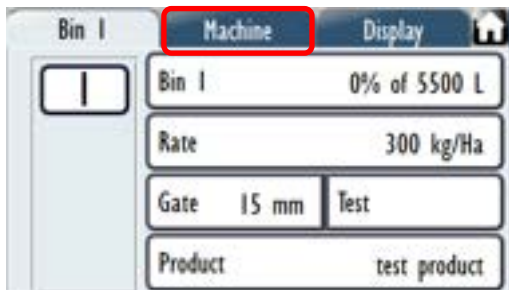

4. Scroll Down and tap "Speed Source"

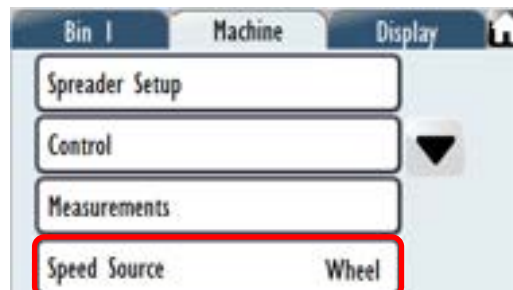

5. Select "GPS"

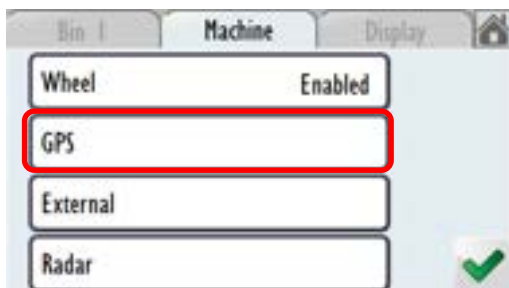

6. Tick "Use GPS For Speed"

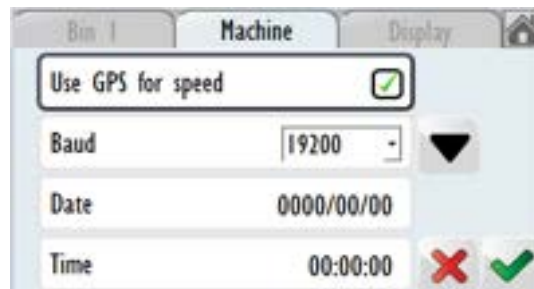

7. Change Baud Rate until Date & Time populate

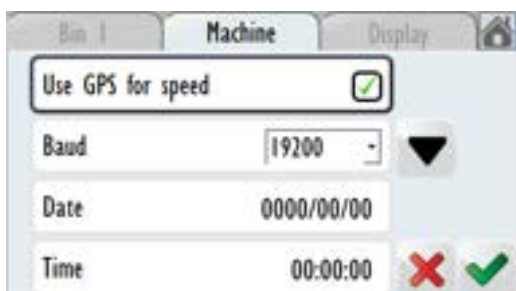

8. Tap Tick to accept changes and exit

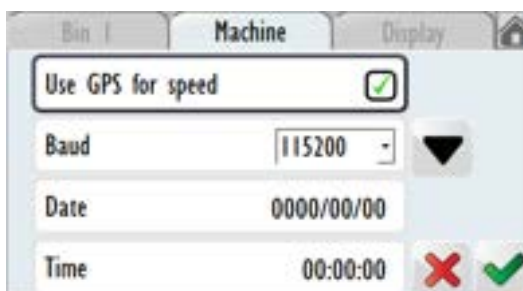

Export GPS Mapping to USB

GPS Mapping data is stored in the memory of the unit. Excessive data stored can cause the unit to become slow and run intermittently. To fix, it is possible to clear the memory or export it to a USB.

1. Tap Settings Icon



2. Tap Job Menu Icon



3. Select Job to Export and tap Export (CSV)

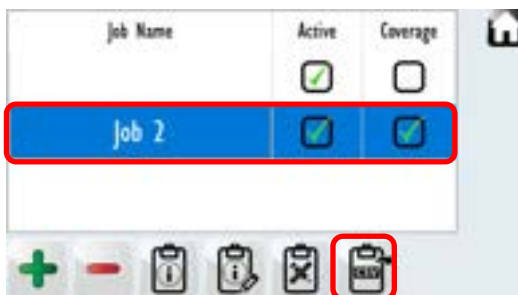

4. Follow steps on next page to clear GPS mapping after exporting

Clearing GPS Mapping

GPS Mapping data is stored in the memory of the unit. Excessive data stored can cause the unit to become slow and run intermittently. To fix, it is possible to clear the memory or export it to a USB.

1. Tap Settings Icon



2. Tap Job Menu Icon



3. Select Job to clear and tap Job Details

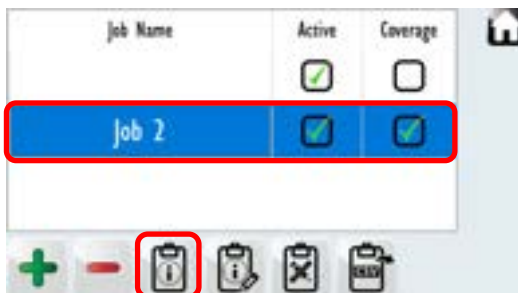

4. Tap Reset Icon



5. Tap Reset Button



Enable Prime Mode

Enable prime mode can be used for troubleshooting and determining if a fault is hydraulic or electrical system related. With enable prime mode active, the conveyor can be run with the machine stationary and spinners not running. If the conveyor can be run with the enable prime mode, the problem is most likely electrical or software related. If not, look at possible hydraulic issues.

1. Tap Settings Icon



2. Tap Setup Menu Icon



3. Tap Machine Tab

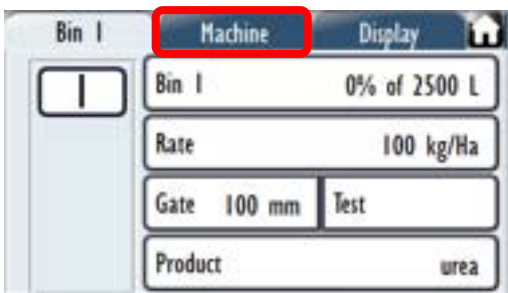

4. Select Control Tab



5. Select Control Speeds Tab



6. Tick box to Enable Prime

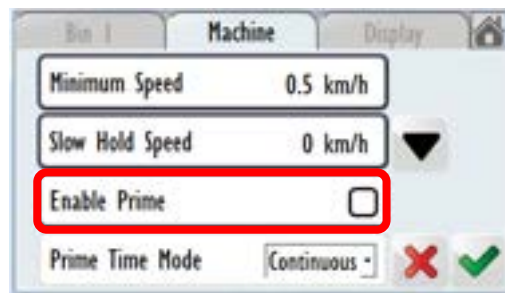

Setting Spinner Turbo and Half Speeds

On tab 2, spinner information and controls are displayed. The half and turbo buttons can be used for quick changing of spinner speeds when required. The half and turbo set speeds can also be controlled independent from left to right and set to different rpms.

1. Tap Settings Icon



2. Tap Job Menu Icon



3. Tap Machine Tab

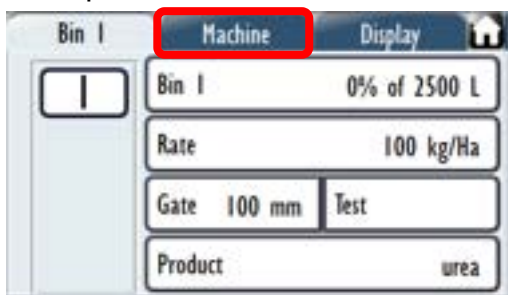

4. Select Control Tab



5. Select Spinner Speed Tab

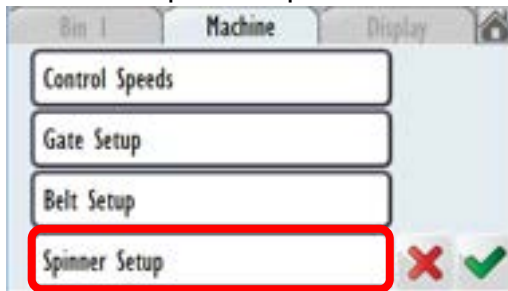

6. Select Spinner 1 or 2 setup



7. Scroll and select Control Speeds Tab

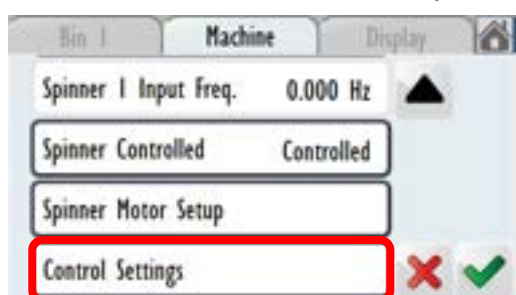

8. Tap Set Speed Points Tab

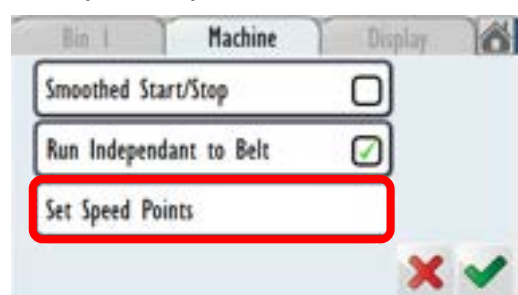

9. Tap half or turbo speed and change as required. Tap tick out to confirm changes and repeat steps 6-9 for other spinner.



Section Control

Overview

When travelling alongside or approaching a boundary, roadside or waterway, it is desirable to avoid spreading fertilizer over the area. With the section control function, quick and individual adjustment is made of left and right spread width.

Up to three preset values are stored, each comprising a spinner speed and distance of throw. It is up to the user to validate the accuracy of each value. On the touchscreen, manually tapping the required throw distance changes the spinner speed and GPS mapping output to reflect the new setting.

The section control function comes pre-installed in the latest software version. It can be activated by following the screen setup procedure below.

Setup

Please note: this is only for a twin spinner machine with individual spinner control.

Download the latest version of the 7000 series software from: www.smartagsys.com

Update the Software on the unit (see 'Updating software version') then proceed with the following:

1. Select the **Setup Tab** 

2. Select the **Settings Tile** 

3. Select the **Machine** Tab, then select **Measurements**:

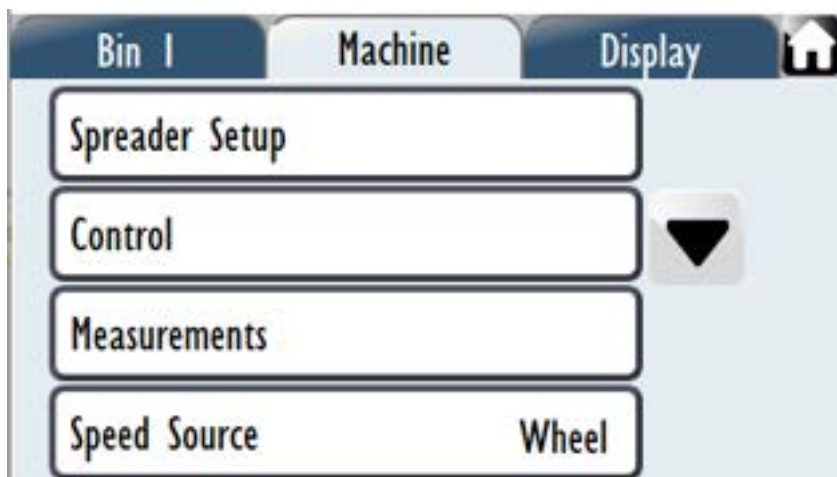

4. Tick **Spinner Width Control** Tile:

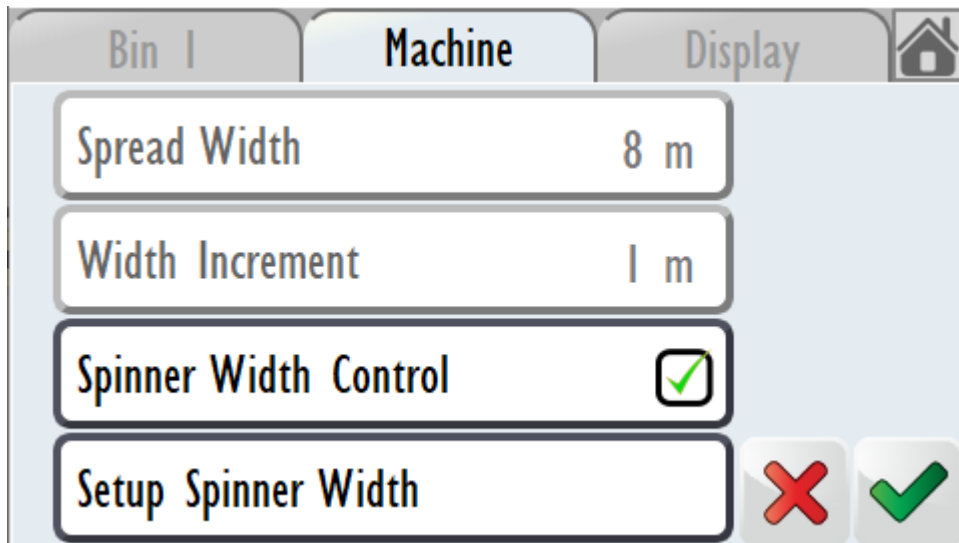

5. Select **Setup Spinner Width** Tile:

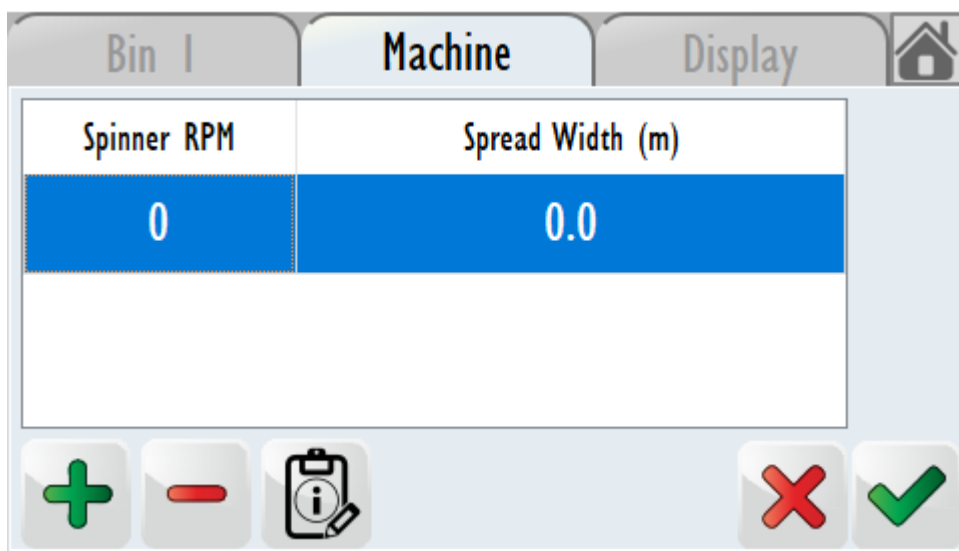

6. Select the  to add in your first section, there are up to three sections per spinner.

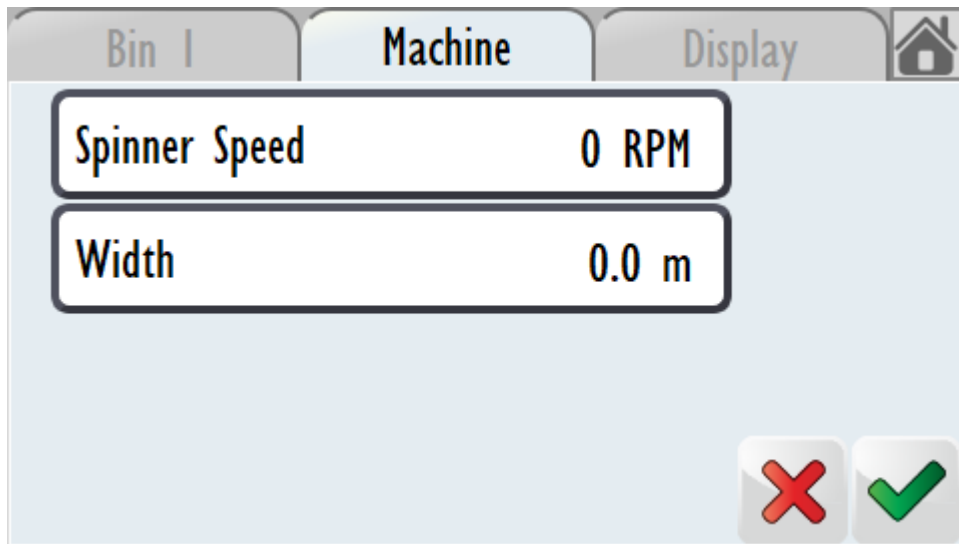

7. Tap **Spinner Speed** and enter the first Spinner RPM value. Tap



8. Tap **Width** and enter the corresponding Spread Width. The Width is the Spread throw distance of a Single Spinner (add up the widths for each spinner to get the total

spread width). Tap



NOTE: It is entirely up to the operator to determine accurate Spinner Speed to Spread Width correlation.

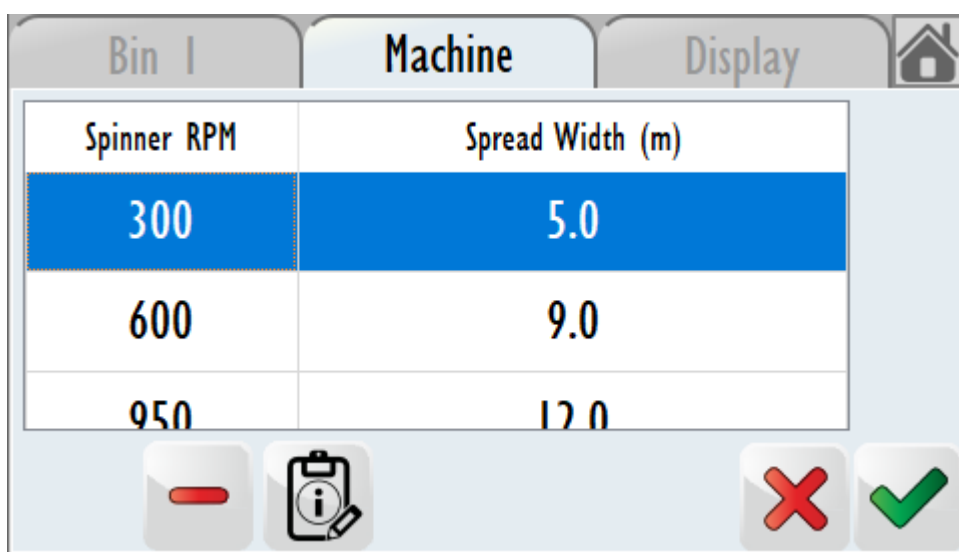

9. Once these setting are completed, the press the **Green Tick**



twice.

10. Select the **Control** Tile

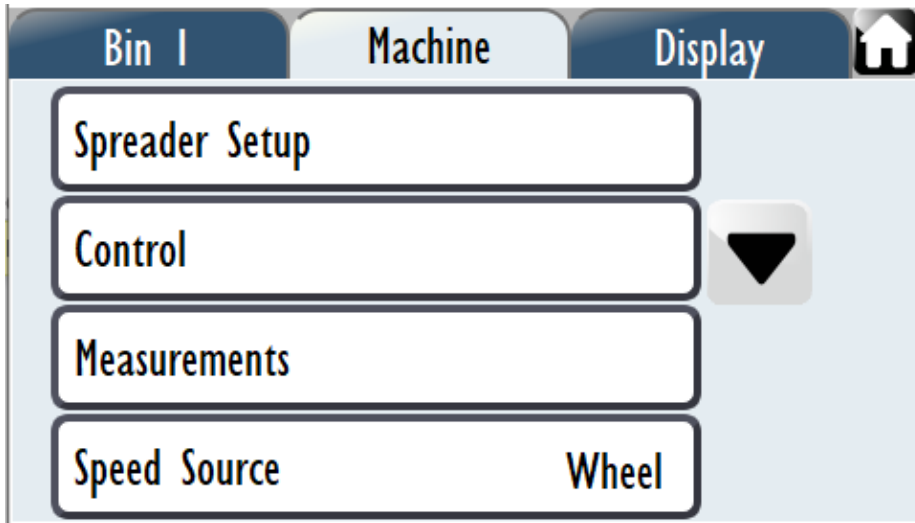

11. Select **Spinner Setup**

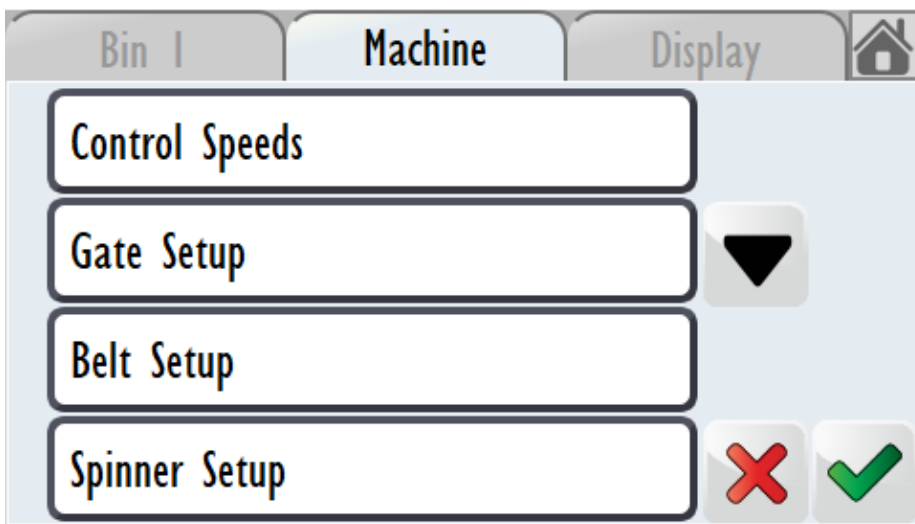

12. Select **Spinner 1 Setup**

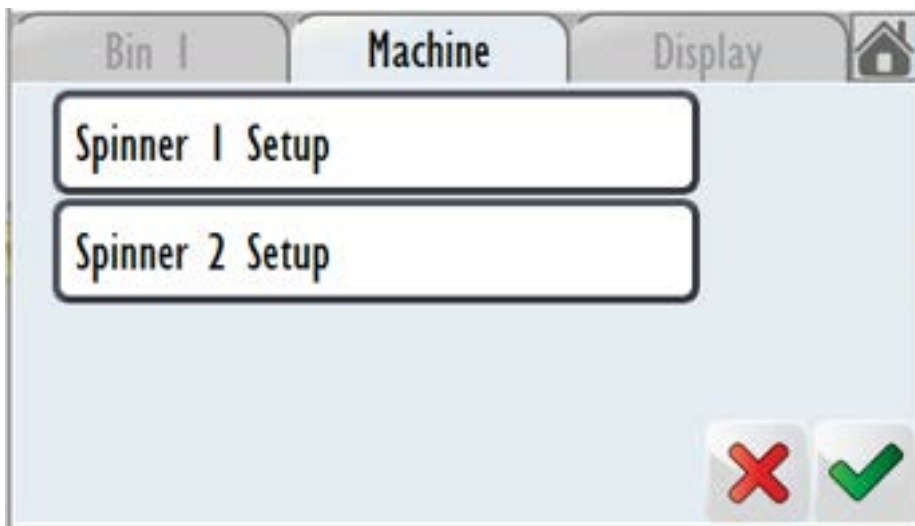

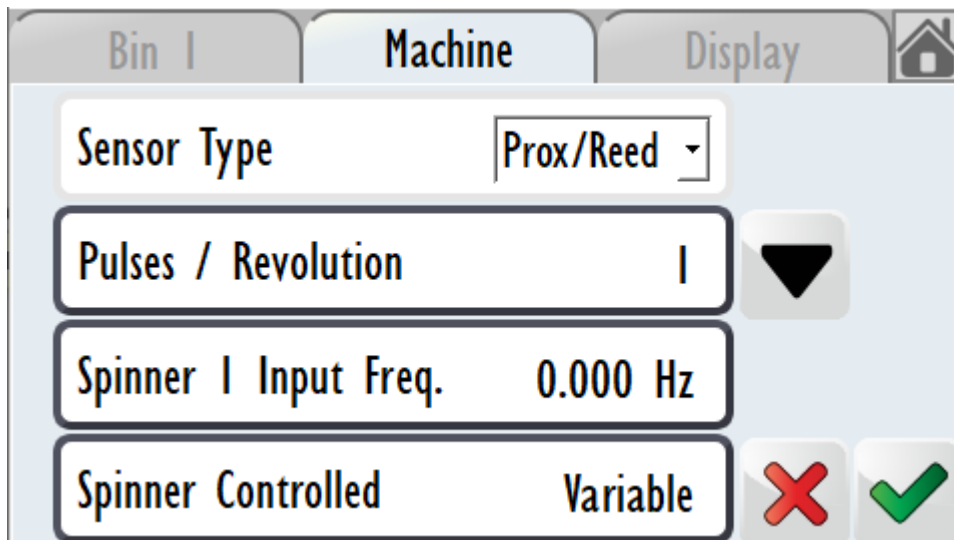
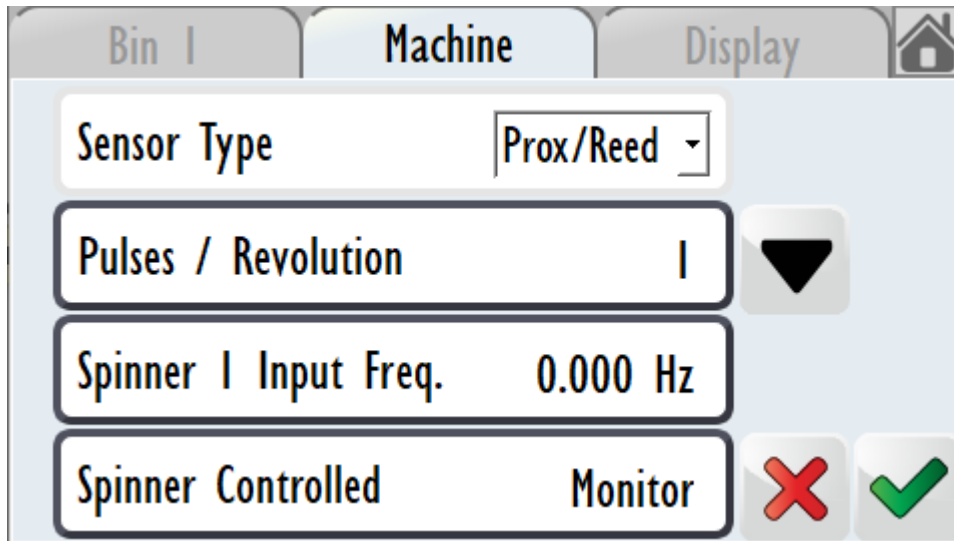

13. Tap **Spinner Controlled** Tile until **Variable** is displayed



14. Once these settings are completed, press the **Green Tick**  until you get the Spinner1/ Spinner 2 setup page.

15. Repeat Steps 12-13 for Spinner 2.

16. Press the **Green Tick**  until the Home Tile appears . Select this to get back to the home screen.

Screen Setup

To utilize the Section Control feature, the screen layout needs to be modified.

1. Navigate to Tab 2. Press and hold the right Quick Spinner Speeds button



2. Tap the Down Arrow until **Spinner Width Controller** appears. Tap this. Tap Tick.



3. Repeat Steps 1 & 2, only this time Press and Hold the left Quick Spinner Speeds button.

4. The screen will now look as below. Note the spread width numbers may differ.

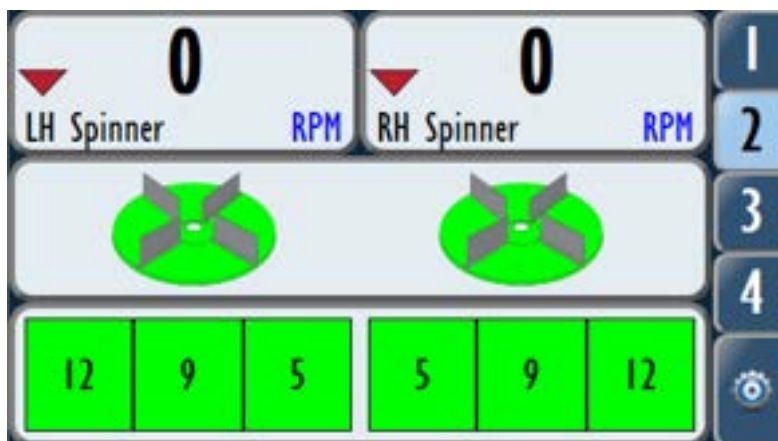

To Remove Spinner Width Controller from Screen

If it is desired to remove the Spinner Width Controller from the screen display, it is easiest to enter the 'Setup Spinner Width' window (see above) and delete the spinner width settings. The screen on tab 2 will now look like this:

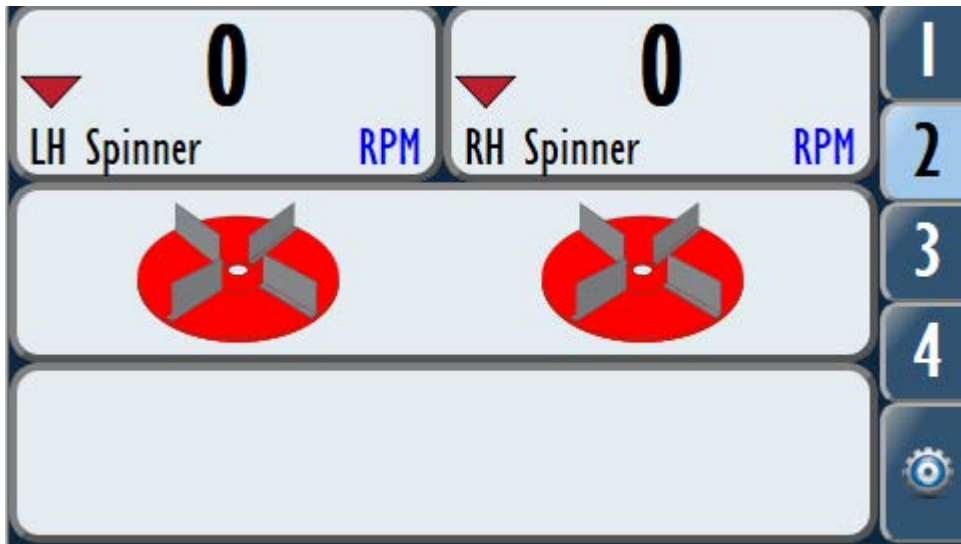

Press and hold on each side of the lower bar to set up the screen to display what is required.

Note: The standard display is 'Quick Spinner Speeds':

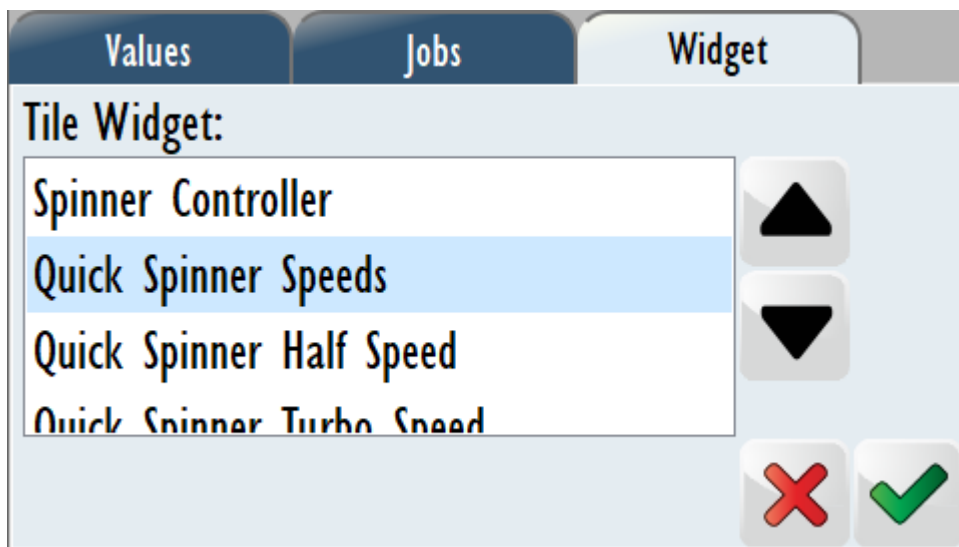

This will need to be selected for both left and right sides of the lower tab.

Operation

Operate the machine as normal: use Run/hold to start/stop spreading, tap spinner discs to green – indicating 'On'.

The first tab will show a green circle in the 'Driving Centres' field. This indicates Spinner Width control is ticked 'On:'

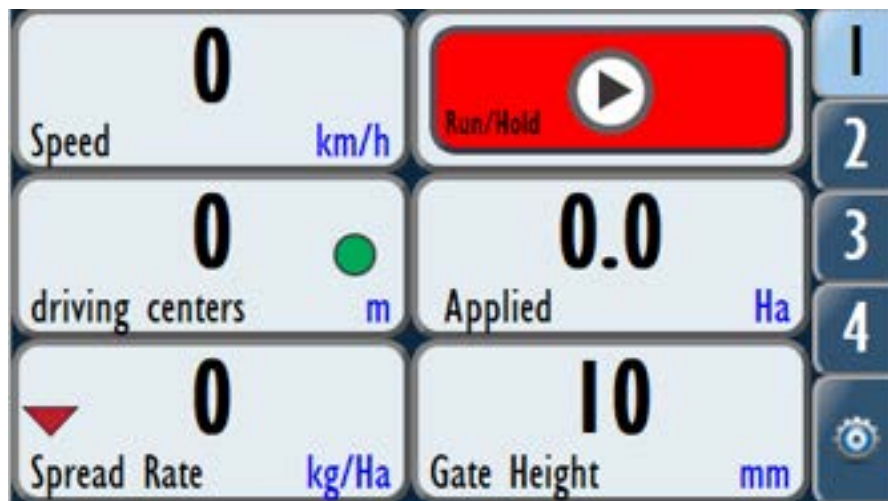

On the spinner control screen (tab 2), the numbers displayed on the lower bar indicate the set spread width for each set spinner speed.

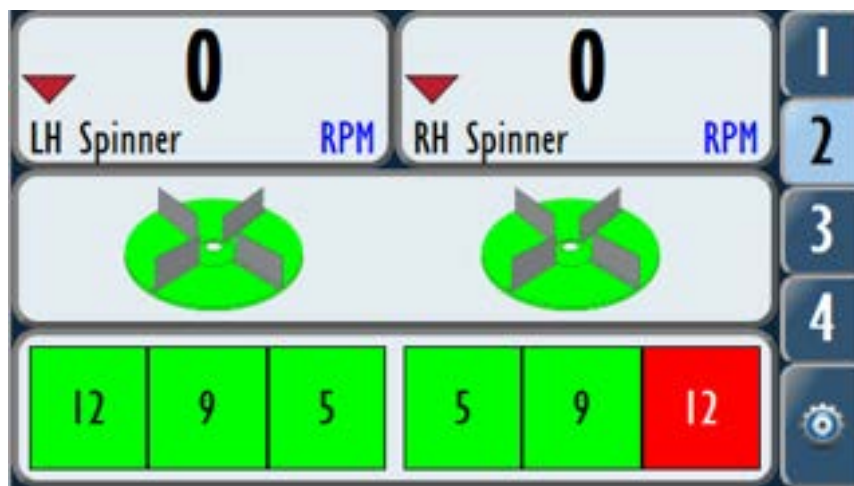

Tapping the desired spread width for either spinner causes that spinner to adjust speed to match the setting.

To fully turn the spinner off, tap the spinner disc itself as per normal.

The GPS output (when fitted) will change to reflect the differing spread width setting.

Note: the belt output rate (weight per hectare) is unaffected by spinner speed. The belt speed will change to reflect the changing area being covered with different spinner speeds. This gives consistent coverage data on output.

Headland Control

Overview

The headland control function uses GPS to determine when a previously spread area has been entered and automatically turns off the belt. Upon reaching fresh ground, the belt turns on. This reduces over-spreading and eliminates the need to estimate start/stop points.

The system can be setup for position of the GPS antenna relative to the spinners, and the appropriate lead-in and lead-out distances configured to ensure best accuracy. The amount of allowable overlap is adjustable.

Setup

Entering Unlock key

A unique Unlock key needs to be purchased for each Farmscan monitor requiring Headland Control. The Serial Number of the monitor will need to be sent to Giltrap Engineering Ltd for an Unlock key to be generated.

Download the latest version of the 7000 series software from: www.smartagsys.com

Update the Software on the unit (see 'Updating software version') then proceed with the following:

1. Select the **Setup Tab**



2. Select the **Maintenance Tile**



3. Select the **About tile** and use the down Arrow to scroll down to the **Enter Unlock Key**:

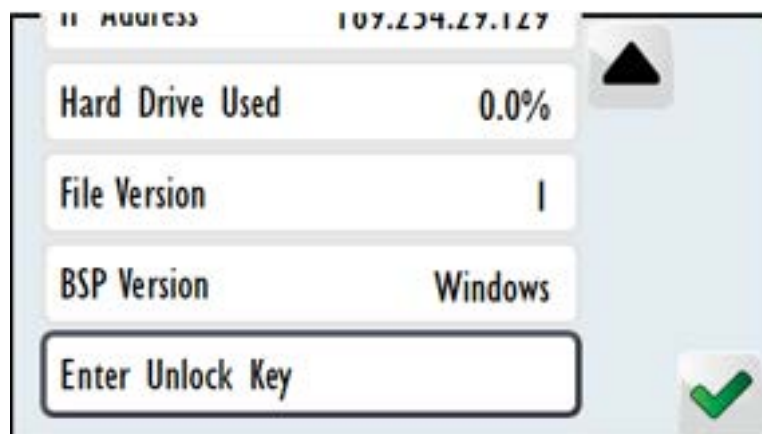

4. Select the **Enter Unlock Key** and then type in your 16 digit unlock code



5. Once the code is entered, press the **Green Tick**



until the Home Tile  appears. Select this to get back to the home screen.

GPS Setup

1. Select the **Setup Tab**



2. Select the **Settings** Tile



3. Select the **Machine** Tab, then select **Speed Source**:

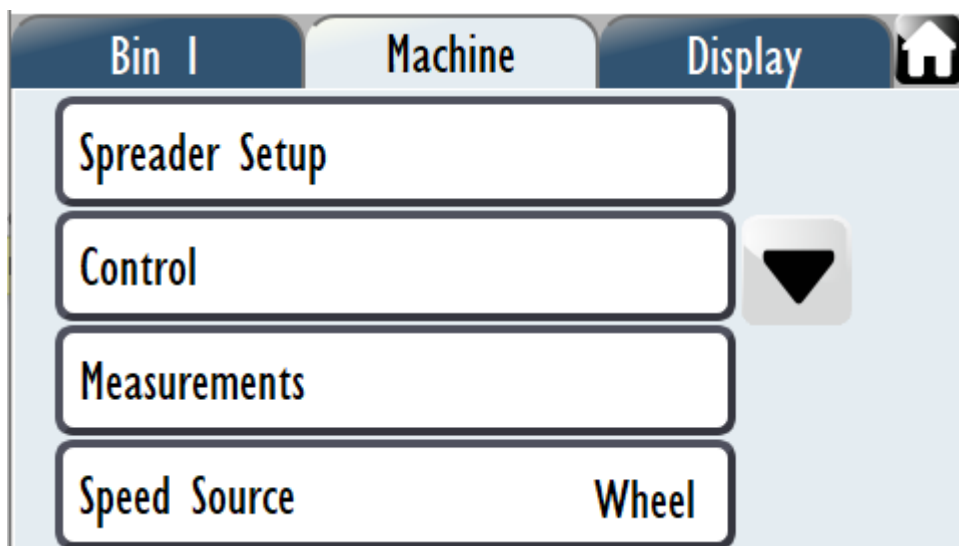

4. Select **GPS** tile:

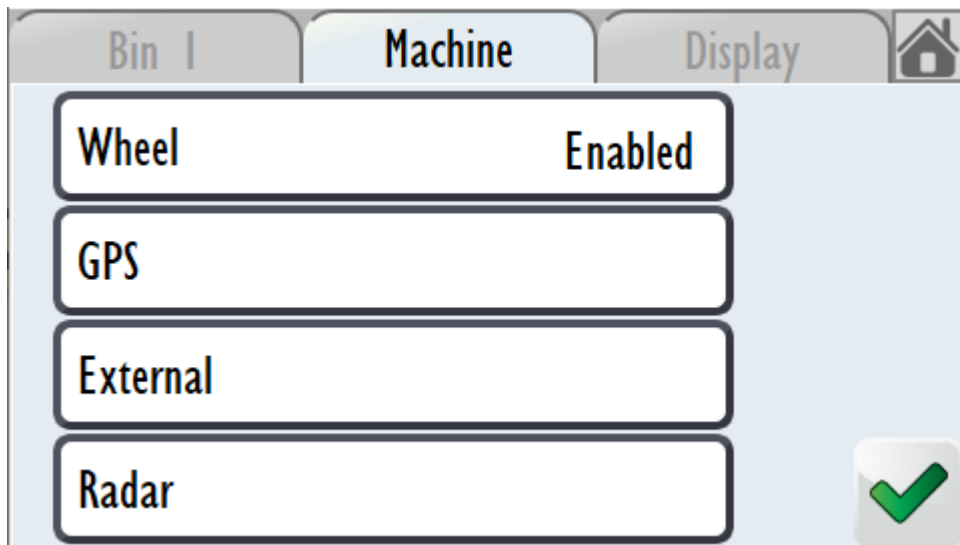

5. Select the **Use GPS for speed** box and then use the Baud down arrow to select the correct Baud:

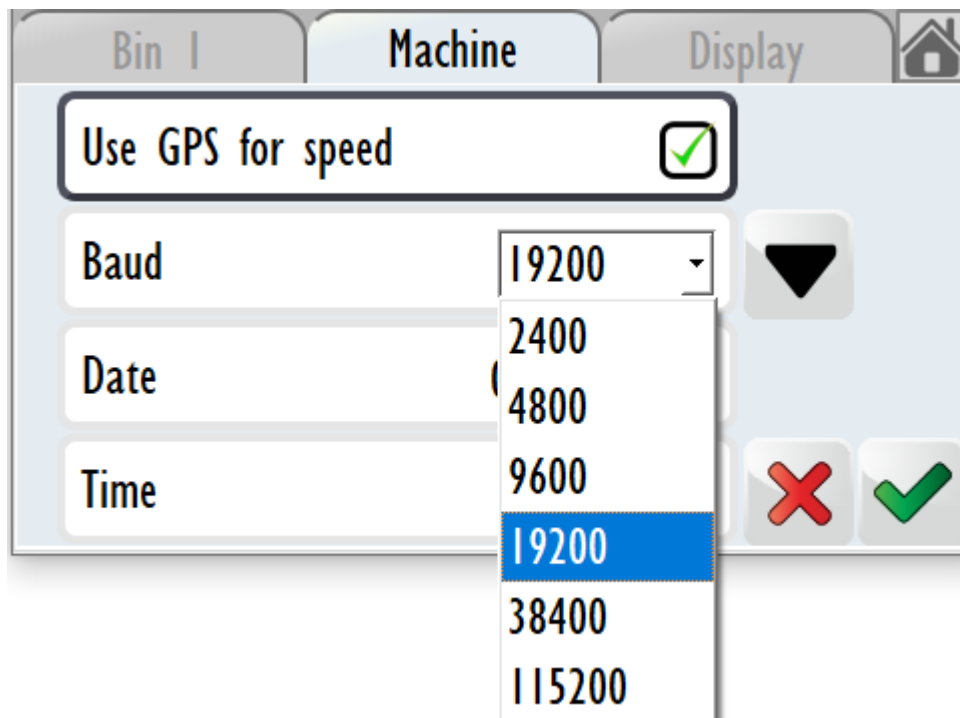

6. Using the down arrow  scroll down until **Implement Offset** tile appears:

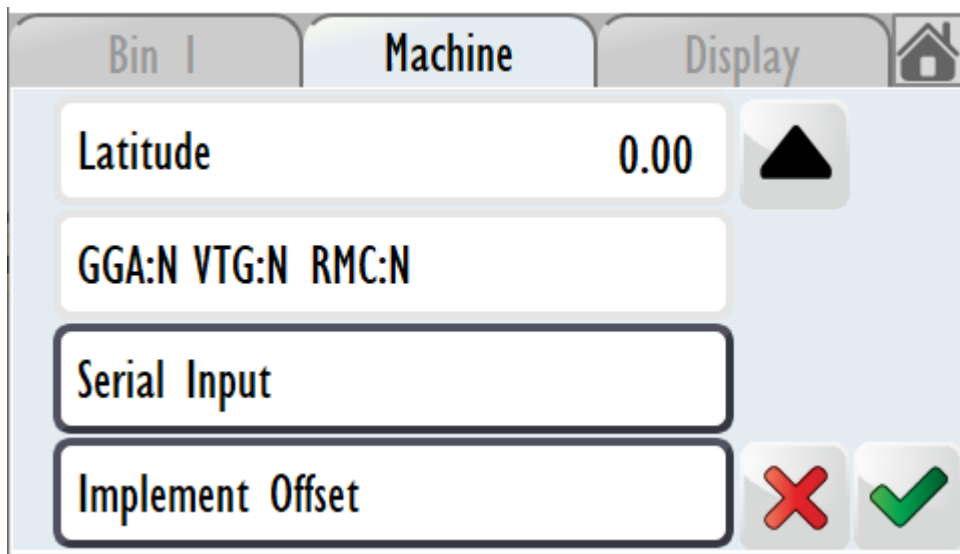

7. Select **Implement Offset** tile to get the headland control setup page:

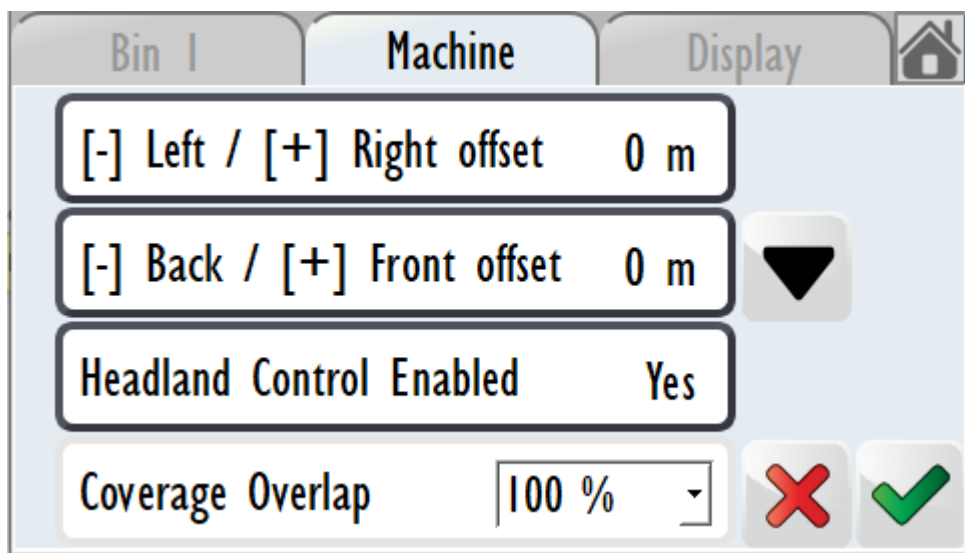

8. The **Left/ Right** and **Back/Front Offsets** are the position of the Implement compared to the GPS:

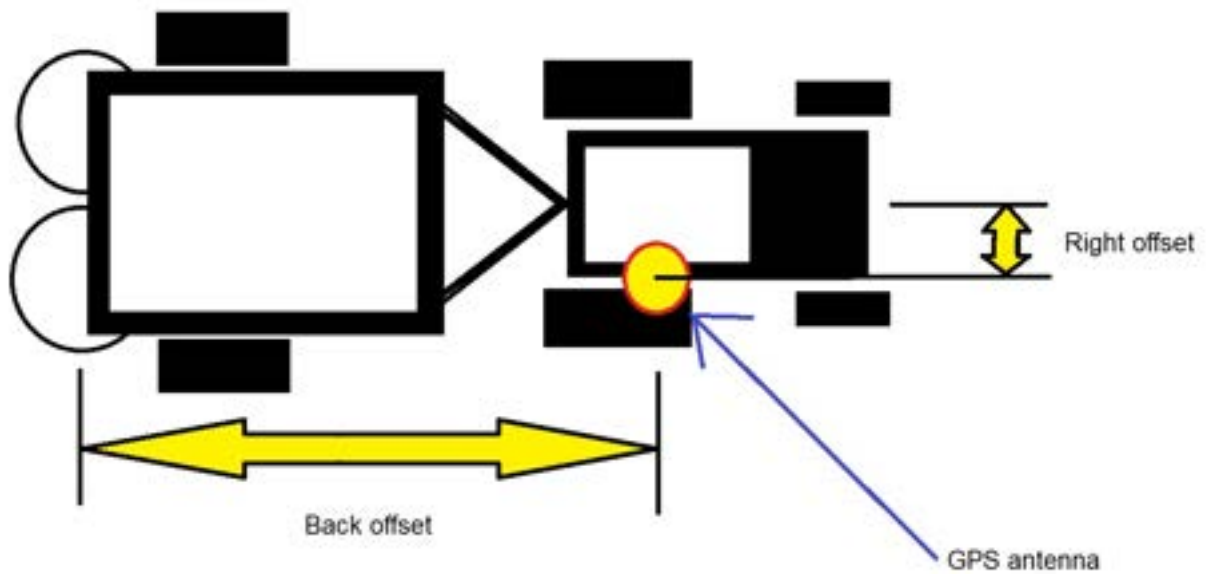

eg if the implement discharge position is 6 meters behind the GPS then select the **Back/Front Offset** Tile. Type in – 6 to represent the 6 meters behind the GPS

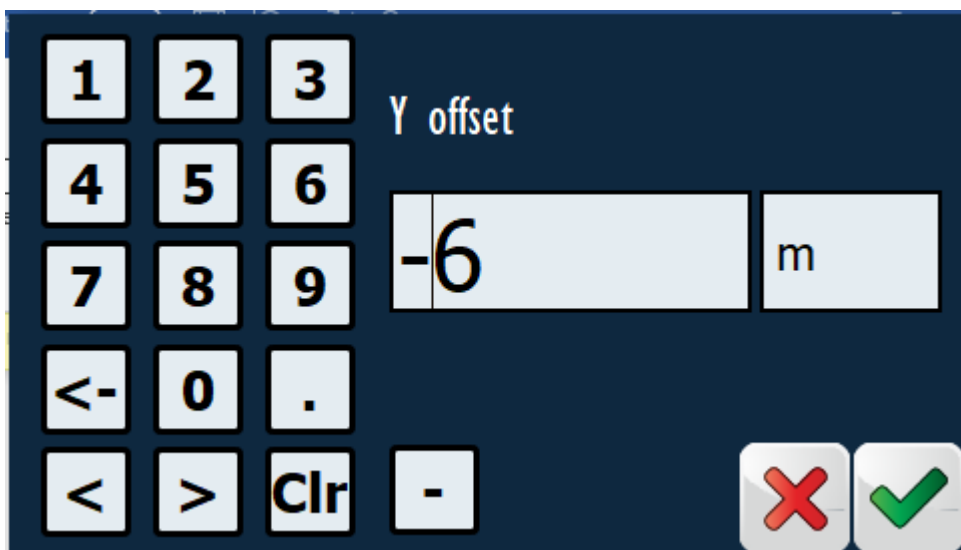

9. Select the **Headland Control Enabled** tile, which will toggle between Yes/No, Select **Yes**.

Adjustable Settings



1. In the 'Implement Offset' page above, scroll down using the **down Arrow** :

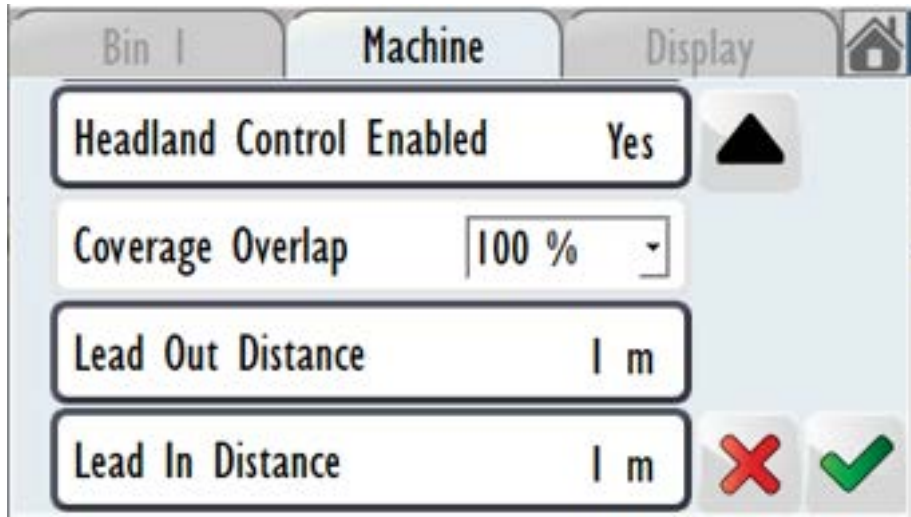

1.a. Coverage Overlap This is a setting to tell the controller how much you want to under or overlap when crossing an already covered area.

Underlap -Below is a representation of zero overlap, (0%). This means that the machine stops delivering product just as the first point of the machine cross any part of the coverage map.

Overlap -Below is a representation of Maximum overlap (100%). This means that the machine stops delivering product after the last point of the machine cross any part of the coverage map.

Please note that most people would set this to 100% overlap just to make sure that they have covered the complete area.

1.b Lead Out Distance. All mechanical control functions have a lag between the time the Controller commands the implement to stop and the time the product finally stops flowing from the implement to the ground. During this time the machine will have

covered a certain distance. If we stop the controller this distance before it reaches its shutoff point, the product will stop flowing to the ground at the correct position.

To determine Lead Out Distance required:

- 1) Set the Lead Out Distance to 0 m
- 2) Drive over a covered area at operating speed, as shown in the below diagram with the system in run mode
- 3) The system should start and start logging as the edge of the covered area, Point A
- 4) Determine where the product actually starts flowing from the spinners, Point B
- 5) Measure the distance between A and B.
- 6) This is your Lead out Distance
- 7) Type this value into your controller.

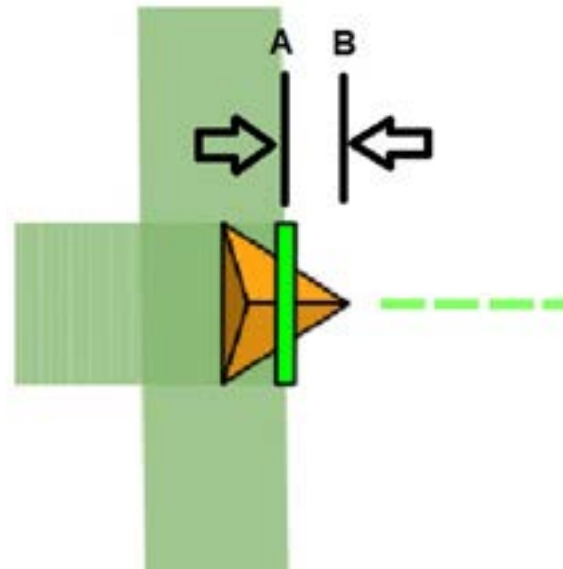

1.c Lead in Distance



All mechanical control functions have a lag between the time the Controller commands the implement to start and the time the product get to the ground. During this time the machine will have covered a certain distance, if we start the controller this distance before it reaches is point of placement the product will make it to the ground at the correct position

To determine Lead In Distance required:

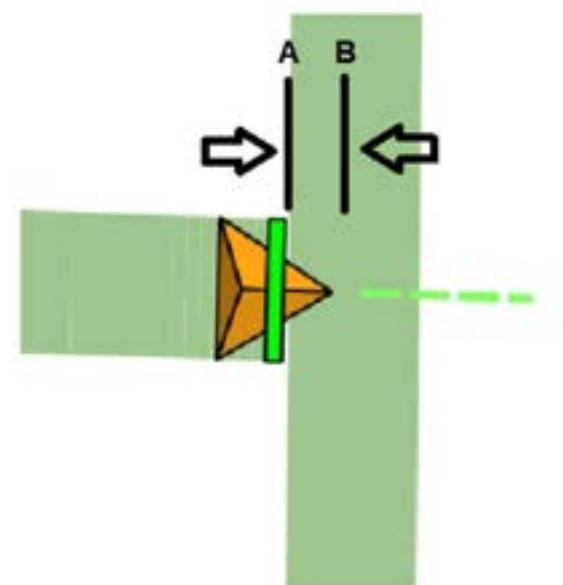
- 1) Set the Lead In Distance to 0 m
- 2) Drive over a covered area at operating speed, as shown in the below diagram with the system in run mode
- 3) The system should shutoff and stop logging as you enter the edge of the covered area, Point A
- 4) Determine where the product actually stops flowing from the spinners, Point B
- 5) Measure the distance between A and B.
- 6) This is your Lead In Distance
- 7) Type this value into your controller.



2. Once these setting are completed,

press the **Green Tick**  until the Home Tile appears . Select this to get back to the home screen.

Screen Setup

To utilize the Headland Control feature, the screen layout needs to be modified.

1. Navigate to Tab 2. Press and hold the right hand spinner disc button

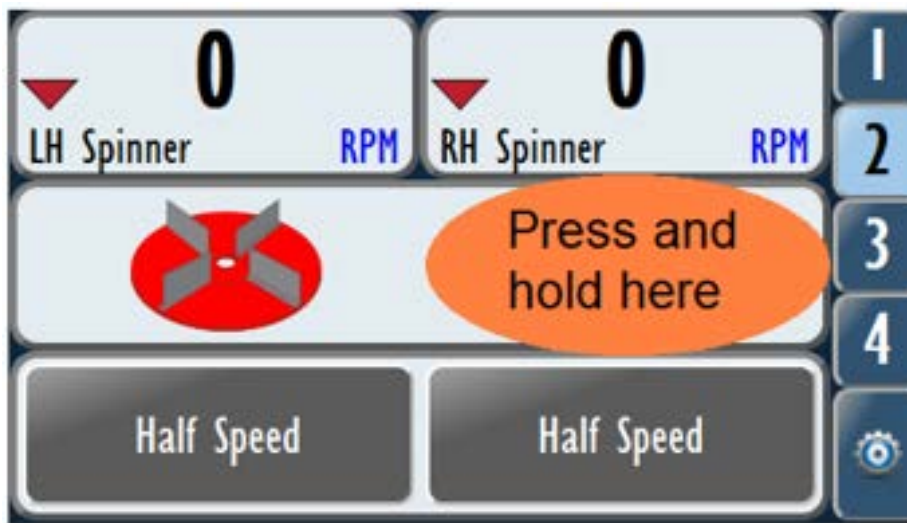

2. This will then display the page as shown below. Select the 'Widget' tab. Use the down arrow and select the **Belt Controller**



3. Once these setting are completed, press the **Green Tick**  once. The screen will now show a Belt Controller graphic:



Operation

With the Setup complete, Headland Control is available for use. To enable it, press the belt Control tile until the belt shows the  for Automatic:

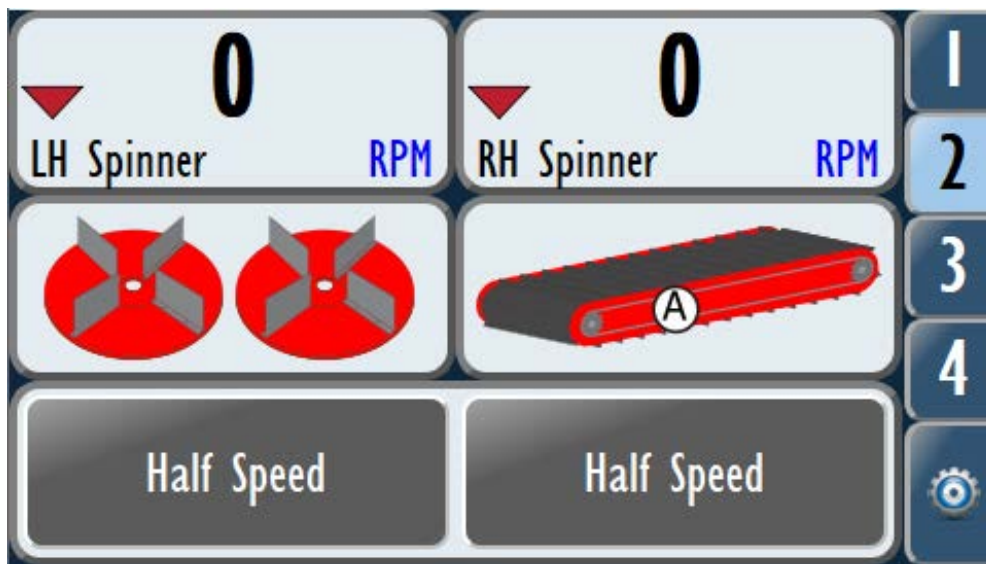

1. Note the belt may become green in colour with the (A) displayed. The Fertiliser Spreader may be used for normal operation (without using headland control) by tapping the belt button until it is green (and the (A) has disappeared). When the belt is fully red (no (A) showing), then the spreader will not operate.
2. The spreader is then operated as normal: set the parameters and press the Run/Hold button to spread when required. When the spreader passes over a previously-spread area to the extent that the Coverage Overlap is set for, the belt will automatically turn off.
3. This may be observed on the GPS coverage screen: Tab 3. When GPS coverage mapping is active, it will automatically display when the unit is spreading and when it is turned off for a headland.
4. It is advisable to spread one or two laps of the headland before 'filling in' the spreading area. This allows a good sized turning area.

Monitor LED Status Lights – 7000 Series screen only

The monitor has two status indicator lights on the right hand side of the screen. These indicators are useful for troubleshooting and are detailed below:

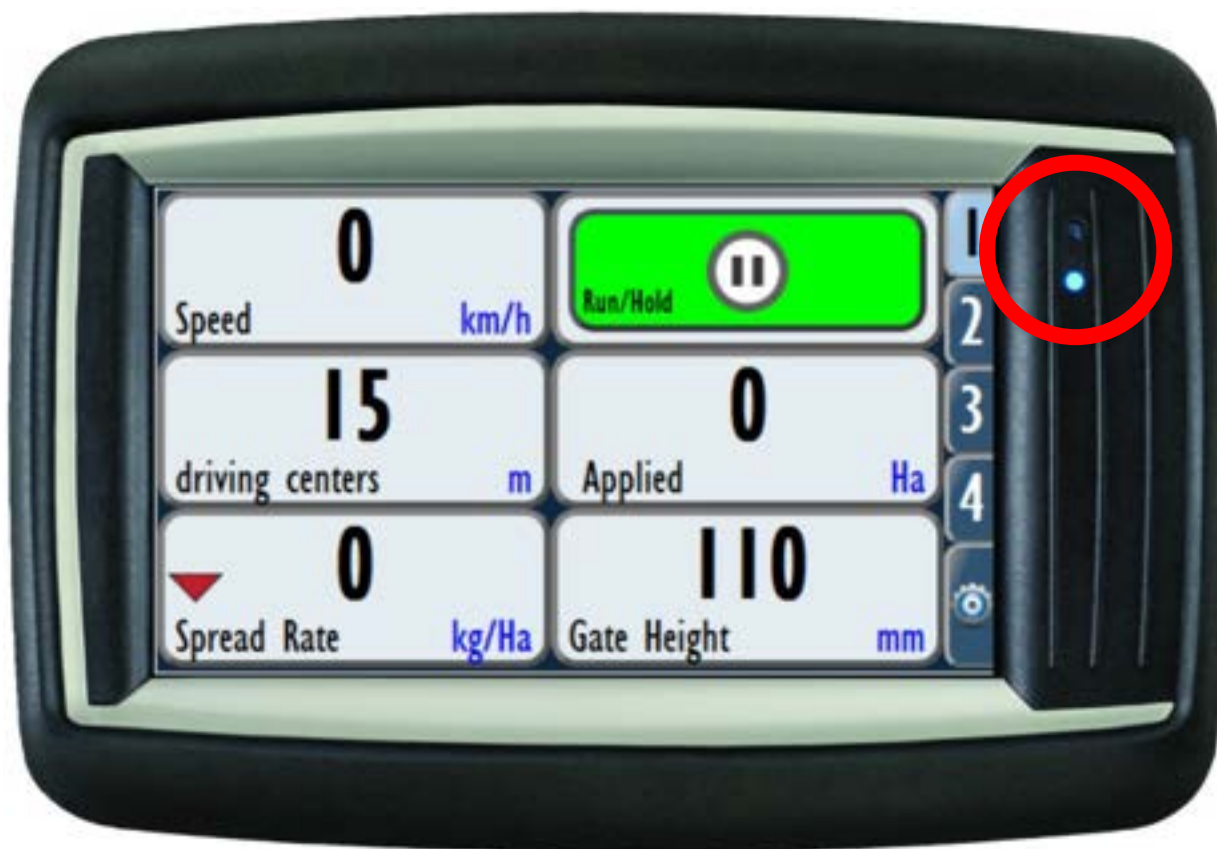

Colour	Status	Explanation
RED	Flashing	Software Crash (Screen Freezes)
RED	Solid	Alarm is on and has not been reset
White	Solid	No Connection to UniPOD
Blue	Solid	Spreader in manual RUN mode – MFC valve/Belt/Spinner or rate is being calibrated/tested/manually controllable
Green	Solid	Spreader in normal RUN mode – MFC valve/Belt/Spinner or rate is being controlled based on speed, application rate and spread width
Green	Flashing	Spreader in HOLD mode

7000-Plus Series screens do not have status lights. Instead, the ‘Settings’ button (bottom right) will flash Red if there is no connection to Unipod.

Troubleshooting

Problem	Cause	Solution
Monitor Not Switching On	Faulty battery connection	Check triangle power plug, main tractor power plug and connection to battery
	Faulty relay	Replace relay
	Blown fuse	Replace fuse
Monitor lags and freezes	Memory full	Export and clear GPS mapping from job. Reset Job
Conveyor Not Operating	Belt slipping	Tension belt
	Enable prime mode selected	Disable prime mode
	Minimum speed set too high	Decrease min speed setting
	Spreading parameters set incorrectly	Check values for product density and spread rate
Conveyor Surging /Stopping and Starting	Belt slipping	Tension belt
	Spreader at lower range of controllable spread rates	Lower door height Increase ground speed Increase spread rate
	Faulty rate sensor	Check sensor on coupling is not slipping on shaft. Check sensor is mounted properly and no bolts are loose
Spinners Not Spinning	Spinners not active	Ensure both spinner icons are selected (green) and set monitor to run
Spinners Not Rotating Fast Enough	Low oil flow	Check tractor hydraulics are adjusted correctly. Connect spinner motors in series
	Excessive hydraulic backpressure	Connect blanked length of hose to ACC port on valve block
Spinners Spinning too fast	Excessive hydraulic flow	Reduce hydraulic flow on tractor
Spinners Surging While Operating	Excessive hydraulic backpressure	Connect blanked length of hose to ACC port on valve block
Ground Speed Stays at 0.0 or is Reading Inconsistently	Faulty wheel speed sensor connection or wiring	Check sensor connector and wiring – replace if necessary
	Damaged speed sensor	Replace sensor
	Incorrectly set speed sensor	Set sensor face 3-4mm from back of wheel studs
Weight Readings Unstable (Load Cells Machines)	Bin weight fluctuating	Zero bin weight and re-tare
	Faulty load cell/cells	Check load cell and wiring/wiring connections
Application Rate is Incorrect or Inconsistent	Wheel speed sensor not reading correctly	Check wheel speed sensor
	Entered door height different to actual door height	Set correct door height in monitor
	Minimum speed settings too high	Decrease min speed and slow hold speeds (Factory = 0.5 and 0 km/h)



Fertiliser Spreader

**Orchard MD
Supplement**



Giltrap Engineering Ltd
P.O. Box 83, 7 Main North Rd
Otorohanga 3900, New Zealand
Phone: +64 7 873 4199
Fax: +64 7 873 8131

Orchard-MD Introduction

This guide is designed to give an overview of the Giltrap Orchard-MD Spreader with front mounted cross conveyor. This machine combines a rear spinner unit, a floor belt which runs both forwards and rearwards, and a front mounted cross conveyor.

For a more in-depth guide covering all features of the control screen and spinner spreading please refer to the full manual.

Contents

Operation	121
SPREAD METHOD SELECTION	121
REAR SPINNER OPERATION.....	121
FRONT CROSS CONVEYOR OPERATION.....	122
<i>Speed Adjustment:</i>	122
<i>Door Height Adjustment:</i>	122
<i>Rate Control Options</i>	123
Maintenance	126
ADJUST FLOOR BELT TENSION	126
ADJUST CROSS CONVEYOR BELT TENSION.....	126
Parts Manual.....	127
CONTENTS	127
CHAIN ASSEMBLY	128
CHAIN BED – DRIVE END	129
CHAIN BED – IDLER END	130
SPINNER ASSEMBLY	131
DOOR – REAR	133
DOOR – FRONT	134
CROSS CONVEYOR.....	135
BIN – REAR.....	136
BIN – FRONT	137

Produced November 2023

Copyright © 2023 by Giltrap Engineering Ltd.
Printed in New Zealand

Orchard-MD Operation

Spread Method Selection

To spread to the rear using spinners, turn both control knobs to point rearwards:



To spread using the front cross conveyor, turn both control knobs to point forwards:



Rear Spinner Operation

The rear spinner is used in the same manner as a Standard Pro-Series Fertiliser Spreader. Refer to the Pro-Series Fertiliser Spreader manual for information

Front Cross Conveyor Operation

When the cross conveyor is turned on, it will always be in operation when the hydraulics are engaged. Spinners must be turned off on the Control Screen.

Speed Adjustment:

The cross conveyor speed may be adjusted by rotating the speed adjustment knob. Screwing out will increase speed.



Release lock nut
and turn this knob
to adjust cross
conveyor speed

Door Height Adjustment:

Door height at both ends is manually adjusted.

The relevant door height must be entered into the Control Screen for accurate rate measurement. When switching between dispensing modes, the door height of the end in use must be entered into the Control Screen.

Rate Control Options

There are two ways front output can be delivered:

Electronically controlled output – spreads a set rate per area covered (also used with spinners)

- This requires spread rate, width, gate height and product parameters be set
- When in operation, floor speed will vary with ground speed

Manually controlled output – ideal for stockpiling or spot unloading

- The floor control is manually overridden - it will move whenever the hydraulics are engaged.
- Overriding the floor can be done two ways:

Manual override: On rear hydraulic block turn belt override knob in until belt speed is achieved.



Loosen lock nut then screw this knob all the way in to manually operate floor.

Electronic override: On the Control screen the parameters will need to be set as for using spinners (spread rate, width, gate height, density).
- Follow the Control Screen steps below:

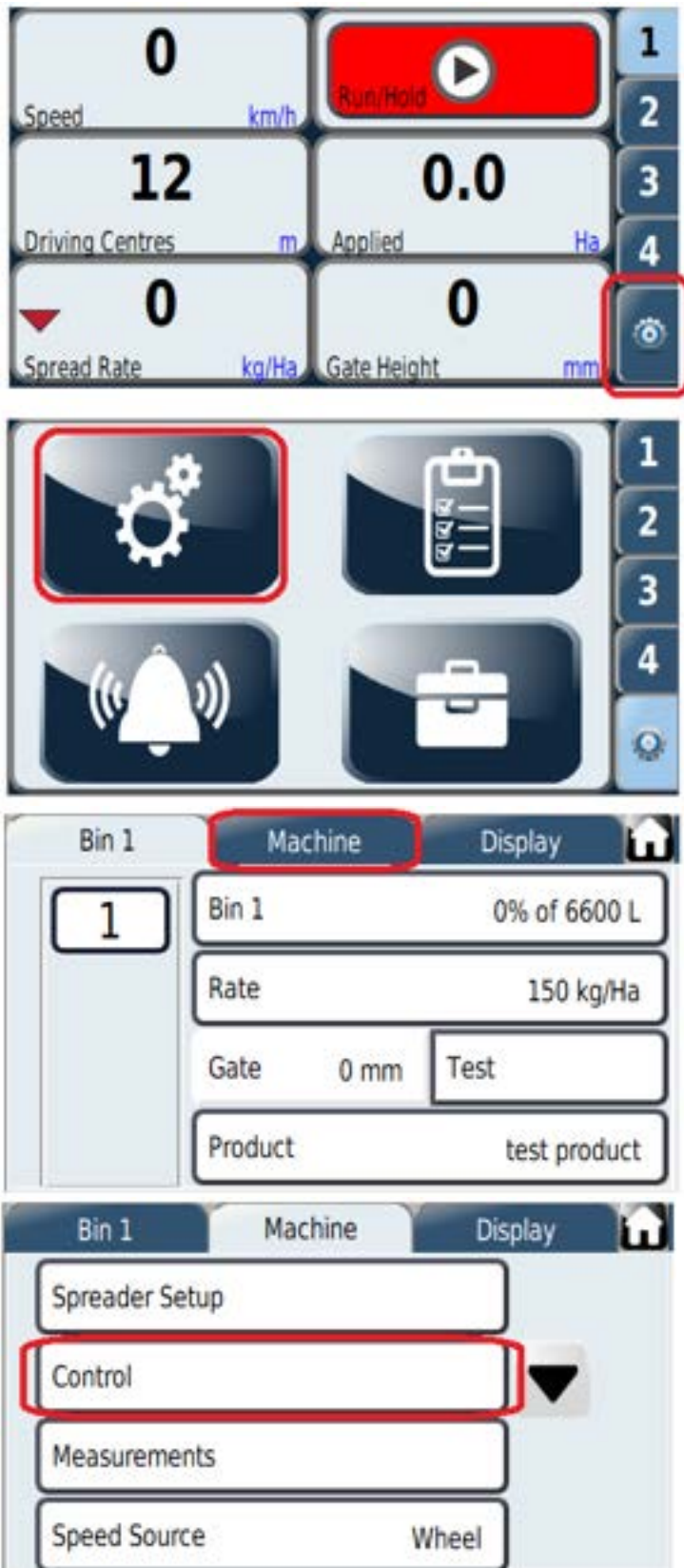

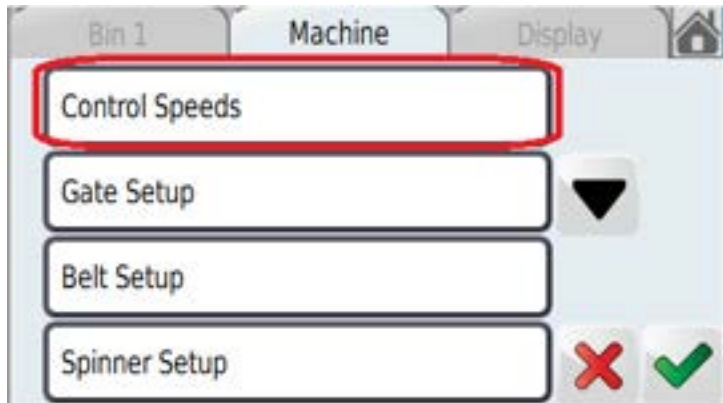

Tick 'Enable Prime'

Note: this option must be un-selected before using spinner mode

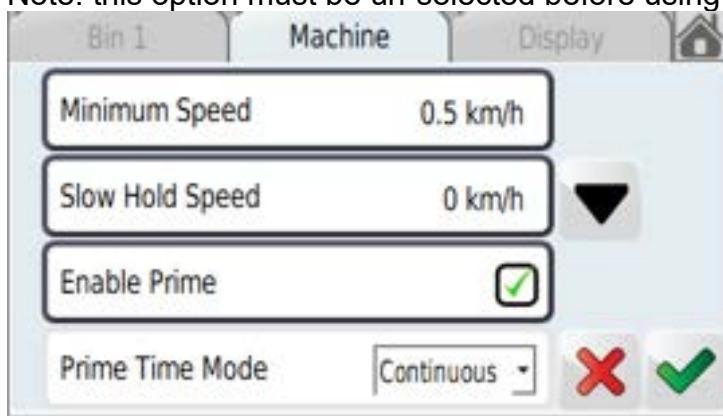

Scrolling down to 'Prime Speed.' This may be adjusted to give faster or slower Belt speed when Enable Prime is active.

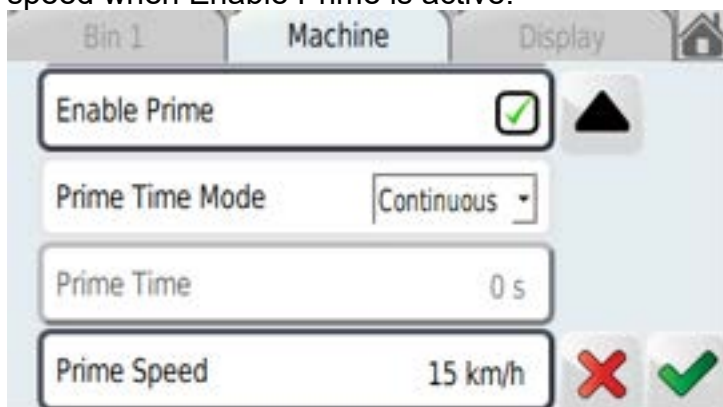

Orchard-MD Maintenance

- In addition to that specified in Pro-Series Fertiliser Spreader manual

Adjust Floor Belt Tension

At the forward end of the floor belt, on each side, loosen the star knob and rotate the cover upwards. The main floor adjustment nuts are exposed.

Loosen the lock nut then wind the inner nut inwards to increase floor tension.

Re-tighten the lock nut.

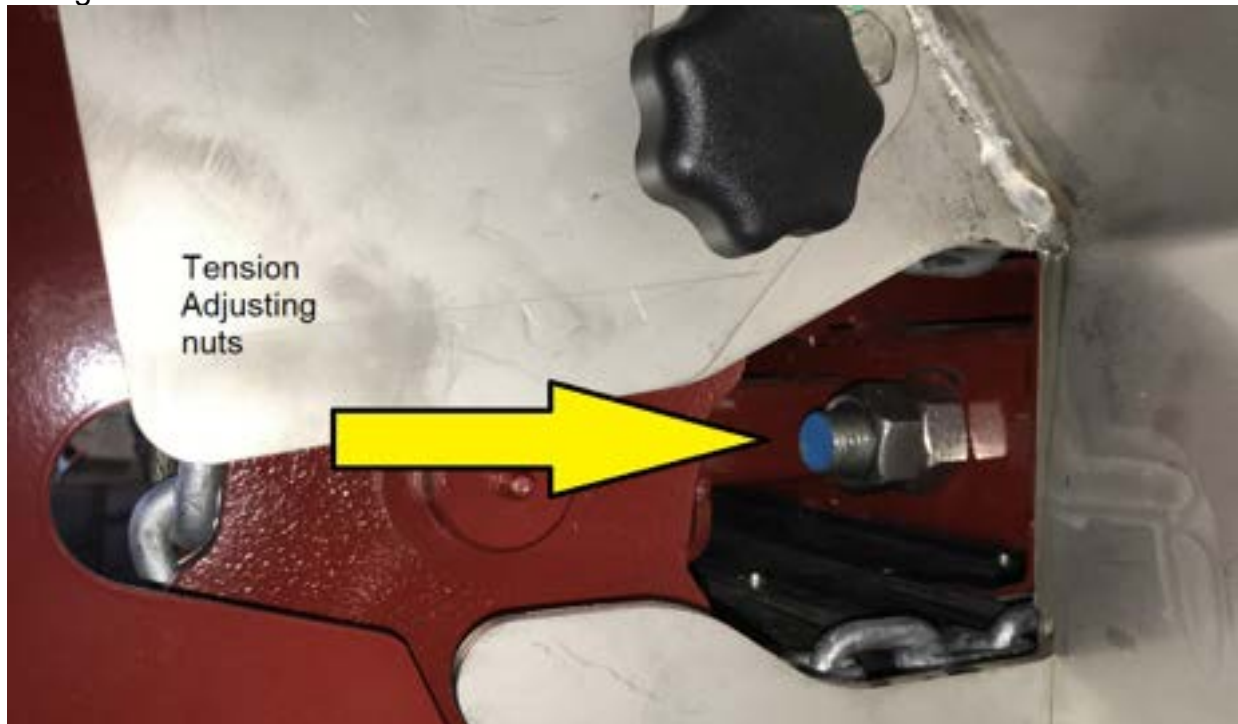

Adjust Cross Conveyor Belt Tension



Orchard-MD Parts Manual

Contents

CHAIN ASSEMBLY	128
CHAIN BED – DRIVE END	129
CHAIN BED – IDLER END	130
SPINNER ASSEMBLY	131
DOOR – REAR	133
DOOR – FRONT	134
CROSS CONVEYOR.....	135
BIN – REAR.....	136
BIN - FRONT.....	137

Chain Assembly

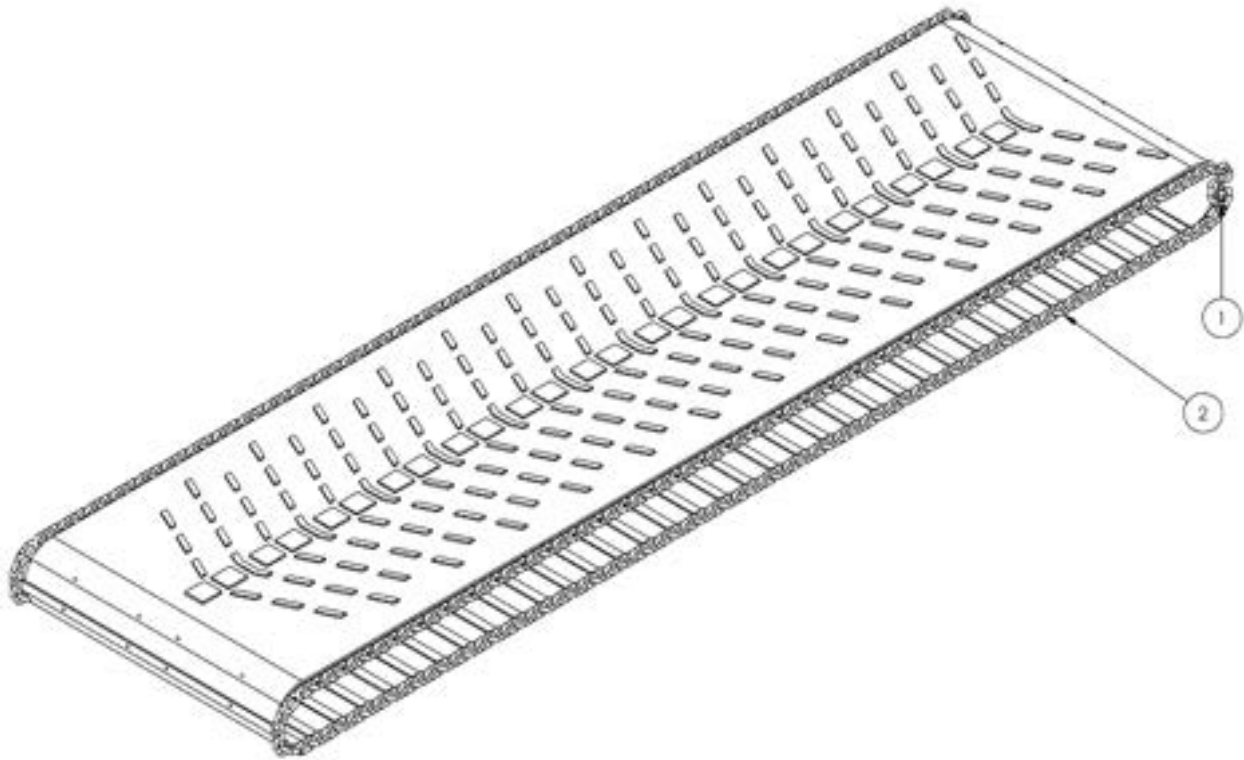

Item	Part Number	Description	Quantity
1	C22044A	Chain Joiner	2
2	14519	Orchard MD Belt Assembly	1

Chain Bed – Drive End

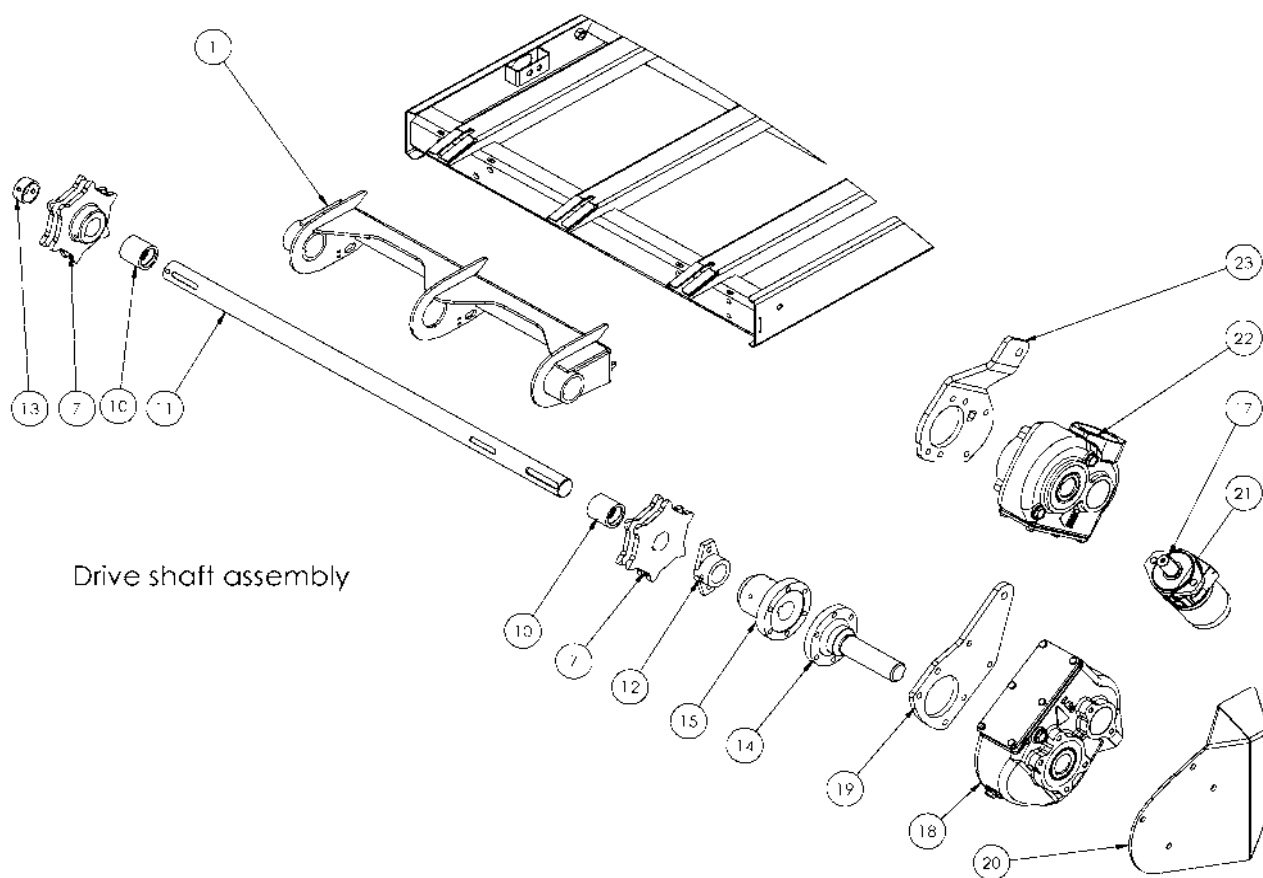

Item	Part Number	Description	Quantity
1	14525	Driveshaft holder	1
7	C22025 40	Drive Sprocket, 40mm shaft, 6 tooth	2
10	14559 (Up to S/N FOLL 18912)	CJ bush	2
	40X50X50 (From S/N FOLL 18913)	Oilybush	2
11	14530	Drive shaft – Orchard	1
12	C21011	Brass Bearing, 40mm, 2 leg	1
13	14172	Driveshaft collar	1
14	135-4149	Male gearbox coupling 40mm	1
15	14531	Female gearbox coupling 40mm	1
17	HYM195-SS	Hydraulic Motor with Speed Sensor	1
18	GBRT190-PT	Gearbox RT190 (From S/N: FOMD18956 on)	1
19	14963	Gearbox mount (From S/N: FOMD18956 on)	1
20	14965	Gearbox guard (From S/N: FOMD18956 on)	1
21	HYM195-SS/SO	Motor Speed Sensor	1
22	GBRT160	Gearbox RT160 (Up to S/N: FOMD18956)	1
23	14726	Gearbox mount (Up to S/N: FOMD18956)	1

Chain Bed – Idler End

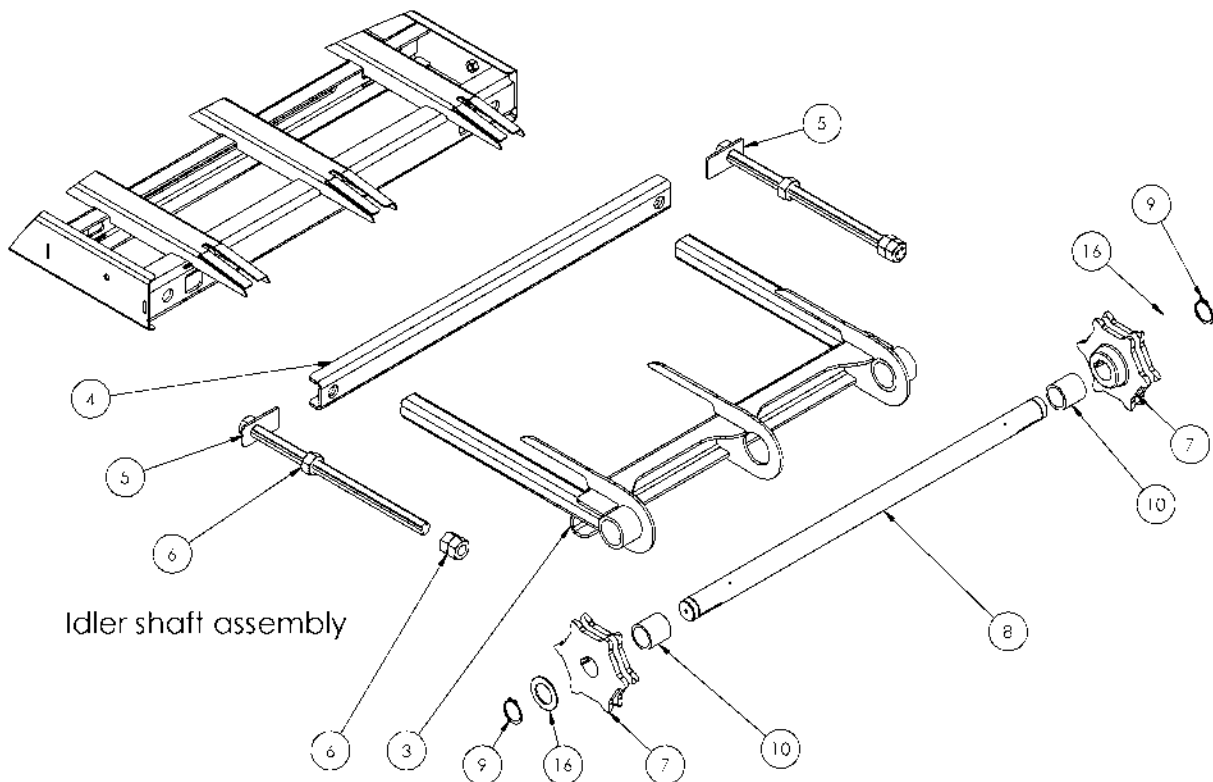

Item	Part Number	Description	Quantity
3	14526	Tensioner	1
4	14527	Pusher	1
5	14528	Tens rod	2
6	N24	Nut	4
7	C22025 40	Drive Sprocket, 40mm shaft, 6 tooth	2
8	14529	Idler shaft – Orchard	1
9	40mm circlip	Circlip	2
10	14559 (Up to S/N FOLL 18912)	CJ bush	2
	40X50X50 (From S/N FOLL 18913)	Oilybush	2
16	WA40x65x3	40mm washer	2

Spinner Assembly

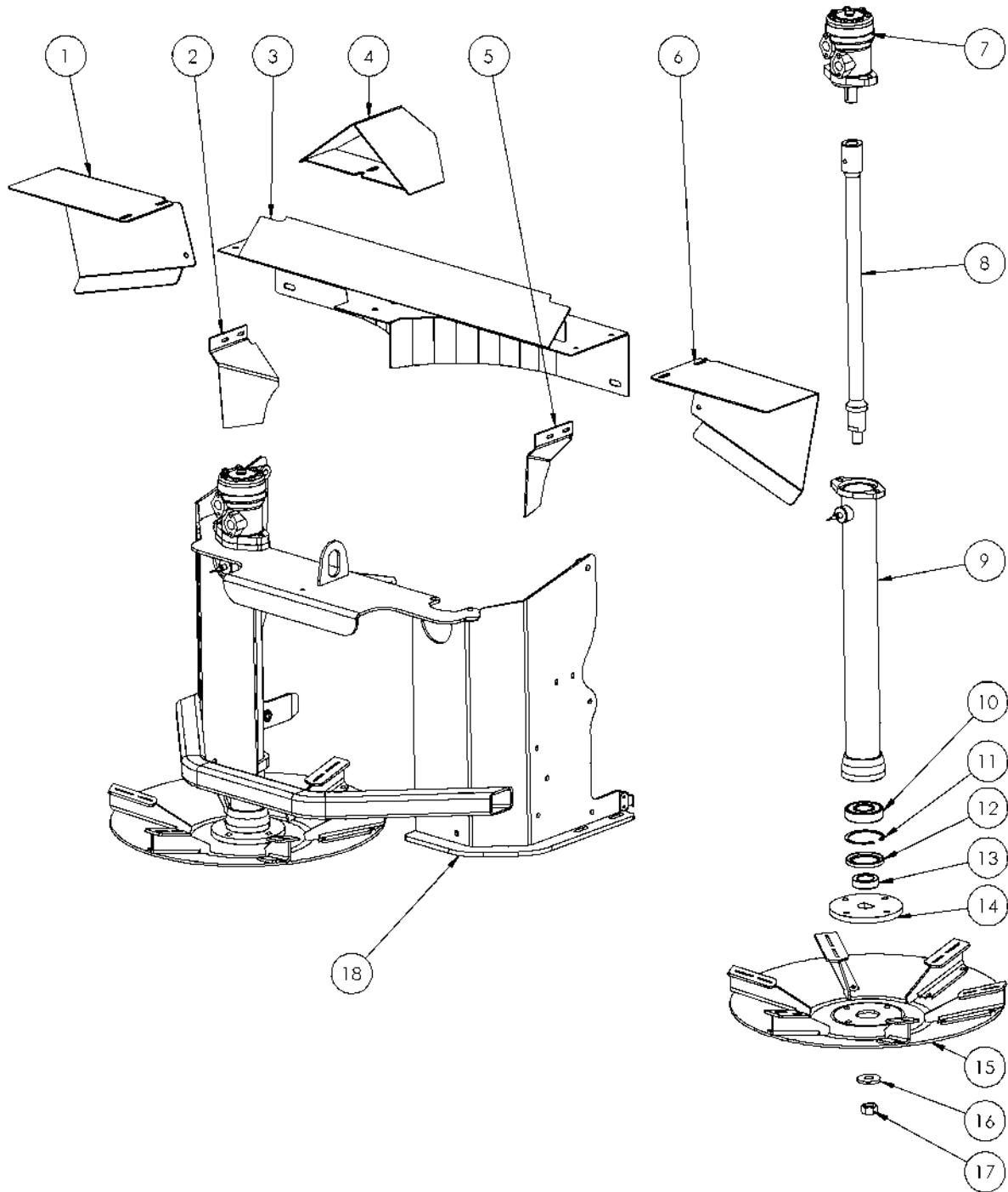

See Table next page

Giltrap Fertiliser Spreader

Item	Part Number	Description	Quantity
	14502	Orchard-MD Spinner Assembly	1
	13590	Spinner Tube assembly complete	2
1	135-0607L	Discharge chute left hand	1
2	14506L	Fert guide left hand	1
3	13038	Spinner Centre Deflector	1
4	13039	Spinner Divider	1
5	14506R	Fert guide right hand	1
6	135-0607R	Discharge chute right hand	1
7	HYM32DAN-PT	Hydraulic Motor 32cc	2
8	135-4102	Spinner Shaft	2
9	135-4112-RH	Spinner tube (with sensor mount)	2
10	BRG6307	Bearing	2
11	CC180	Circlip	2
12	SL558008	Seal	2
13	135-4200	Seal sleeve	2
14	135-1048	Spinner mount plate	2
15	13517	RH Dual Side Stainless spinner disc complete	1
	13516	LH Dual Side Stainless spinner disc complete	1
16	135-1069	Spinner disc centre washer	2
17	NN20	Nut	2
18	14503	Spinner weldment	1

Door – Rear

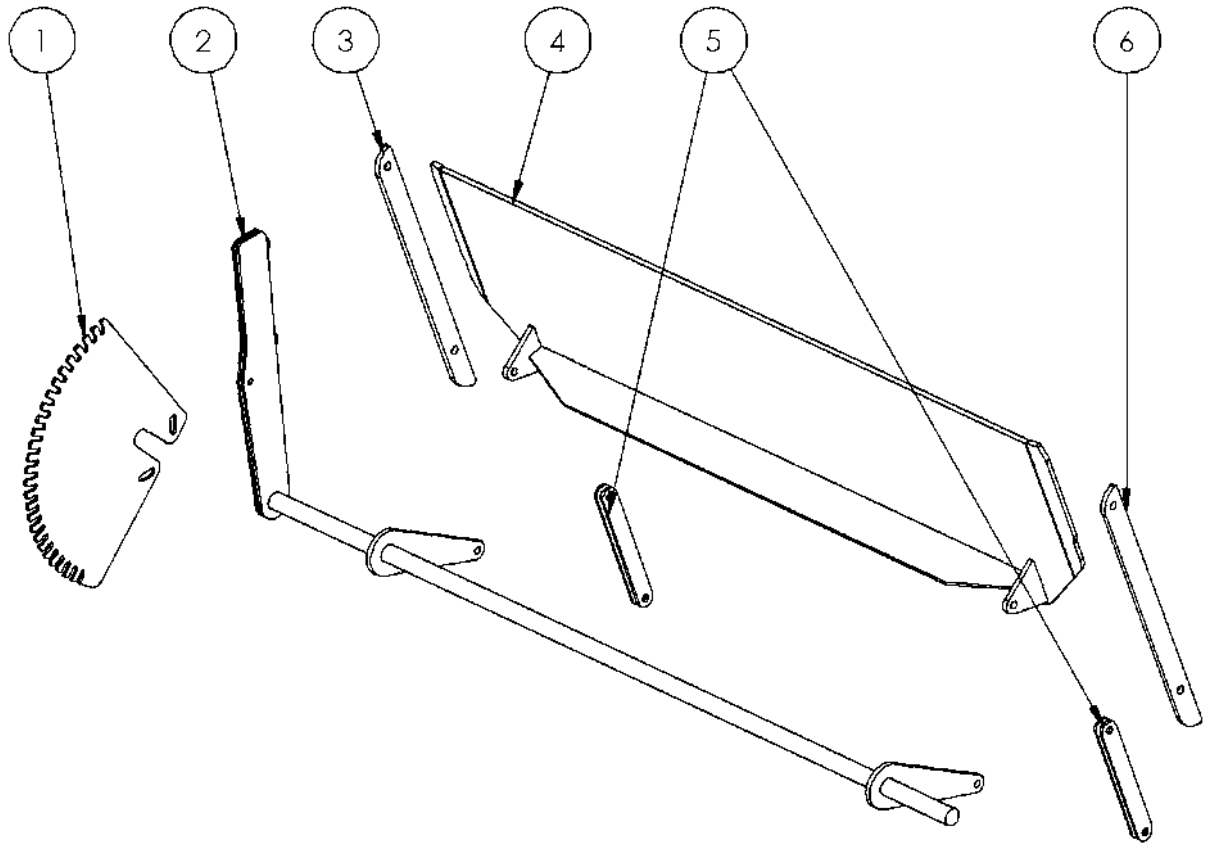

Item	Part Number	Description	Quantity
1	14638	Door positioner	1
2	14512	Rear door height adjuster	1
3	14510	Rear door guide	1
4	14511	Rear door	1
5	135-0562	Door adjuster link – mini	4
6	14510	Rear door guide	1

Door – Front

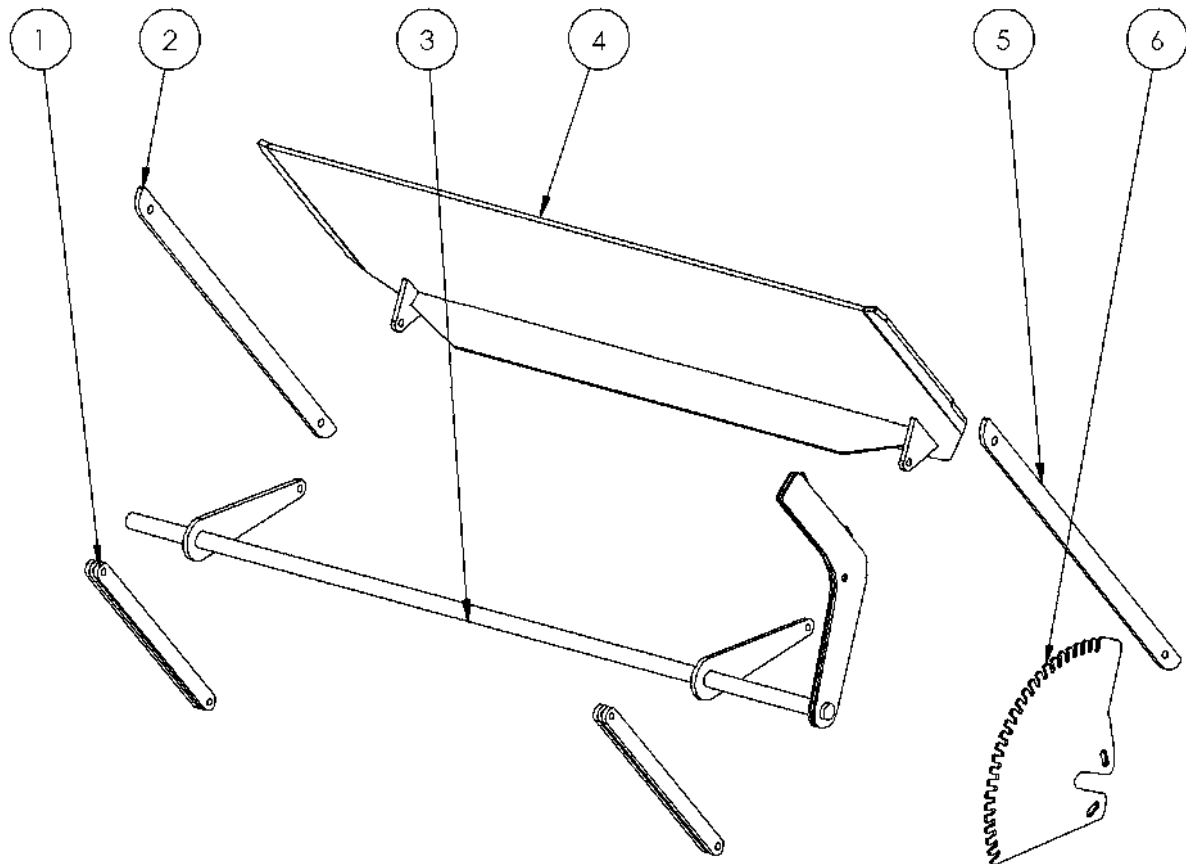

Item	Part Number	Description	Quantity
1	14516	Front door link	4
2	14513	Front door guide	1
3	14515	Front door adjuster	1
4	14514	Front door	1
5	14513	Front door guide	1
6	14539	Door positioner	1

Cross Conveyor

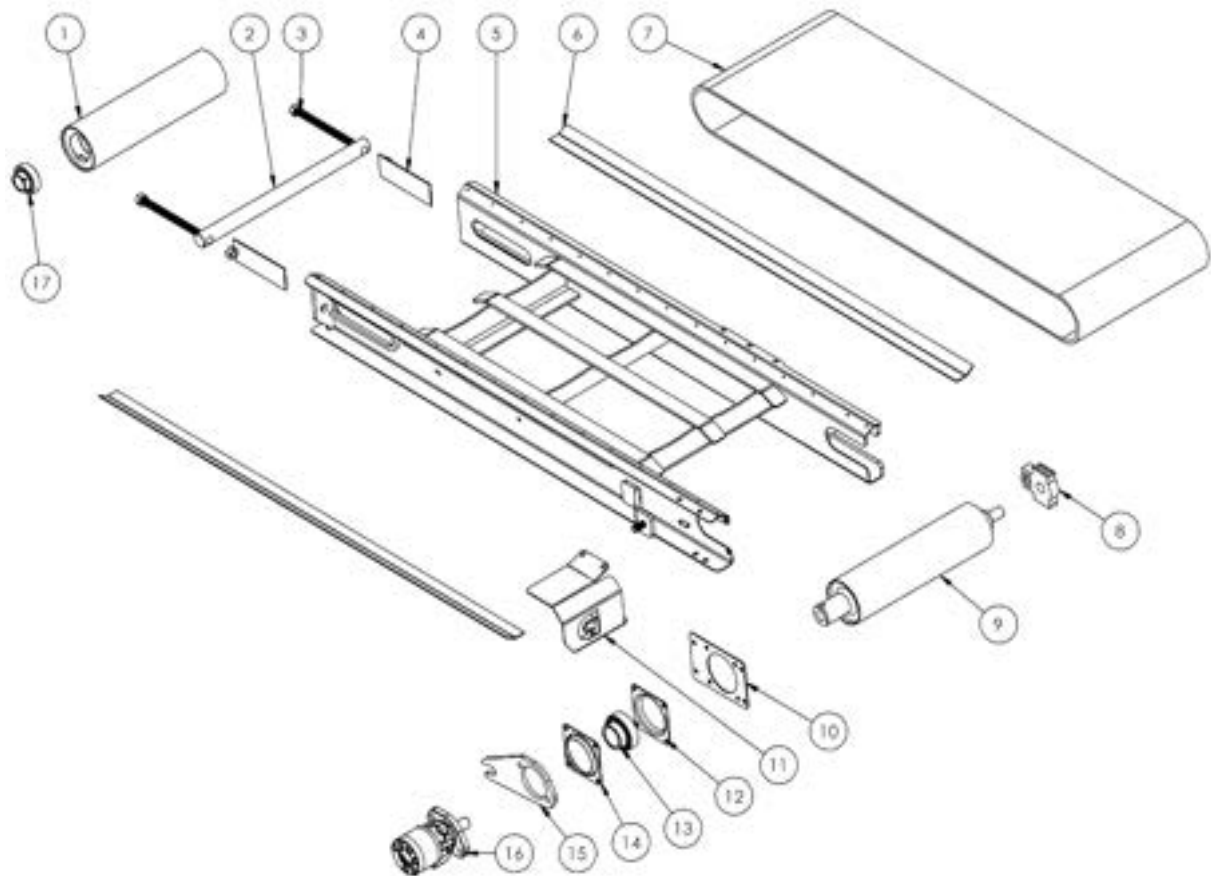

Item	Part Number	Description	Quantity
	14496	Front cross conveyor complete	1
1	10672	Idler roller	1
2	10674	Idler shaft	1
3	596-1004	Tensioner rod	2
4	780-2006	Adjuster nut slide	2
5	14497	CC weldment	1
6	14500	Sealing strip	2
7	10676	Conveyor belt	1
8	HSGTU505	Bearing housing, take up, 25mm	1
9	10673	Drive roller	1
10	14498	Conveyor bearing mount	1
11	14640	Guard	1
12	BUC-048	Conveyor bearing shell	1
13	BRGYAR210-2F	Bearing insert, 50mm	1
14	BUC-048	Conveyor bearing shell	1
15	BUC-095	Motor mount	1
16	HYM65-PT	Parker TE065	1
17	BRGYAR207	Bearing insert, 35mm	2

Bin – Rear

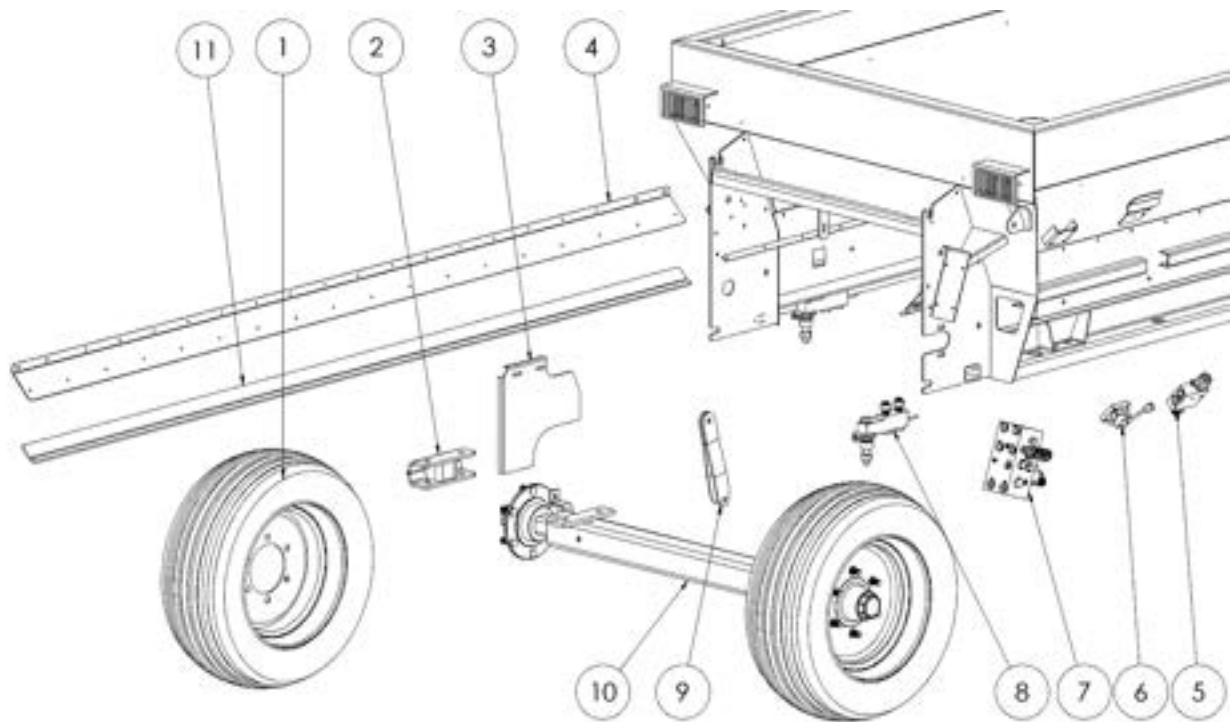

Item	Part Number	Description	Quantity
1	WHLA10.0/75-10	Wheel Assembly (confirm size)	2
2	11297	Raising block	2
3	14504	Centre divider	1
4	14508	Seal strip retainer	2
5	HYHCV841P8PMR10-NFCD K	Directional valve	1
6	HYVD4POPC	Diverter valve	1
7	HYHCV3656	Valve block	1
8	13028	Load cell assembly	4
9	135-0866	Gearbox hanger	2
10	13427	Axle	1

Bin – Front

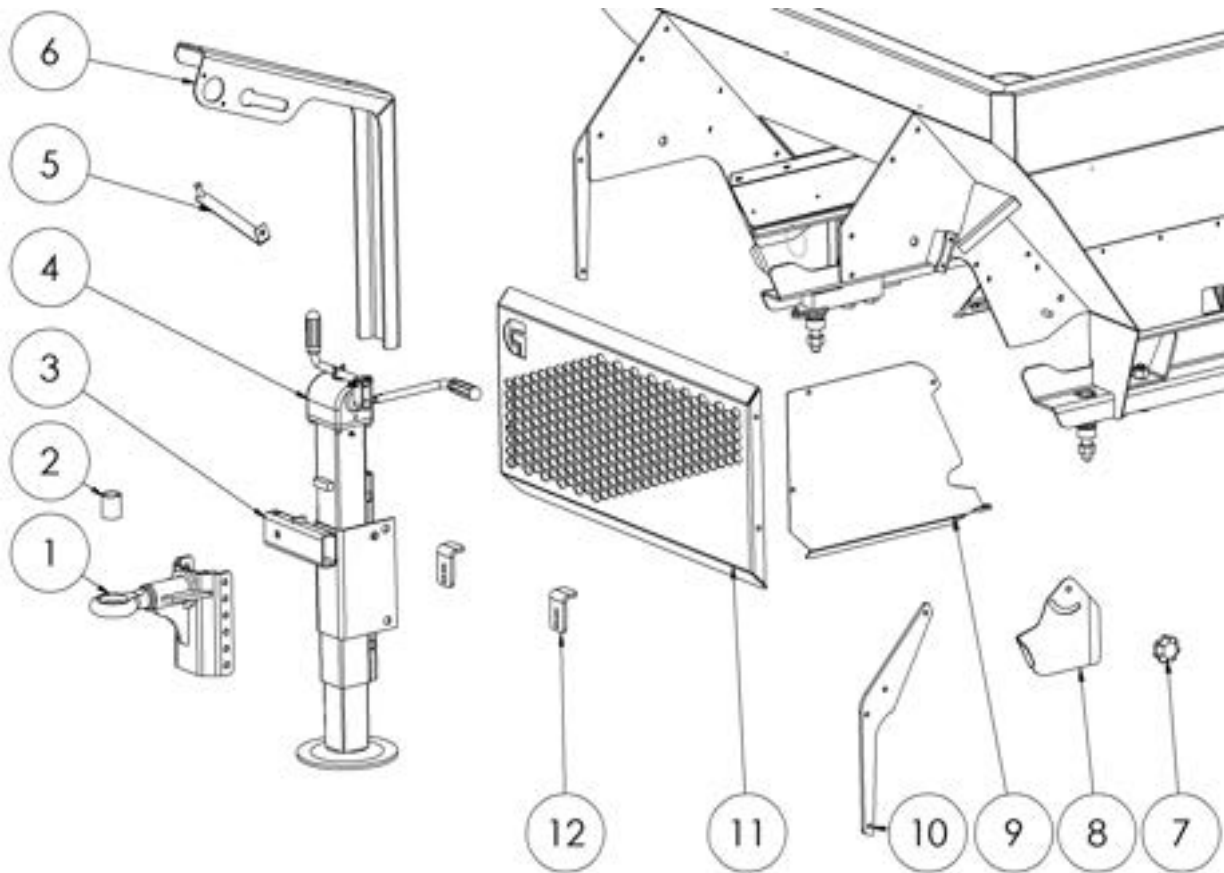

Item	Part Number	Description	Quantity
1	127-2521	Small tow hitch	1
2	14536	Tow eye bush	1
3	14501	Jack mount	1
4	301-4020	Jack	1
5	14639	Location rod	1
6	14540	Hose holder	1
7	Comac 2378	Star knob	2
8	14507	Side cover	2
	Specify side for above part		
9	14495	Gap filler	1
10	14518	Connector	2
11	14517	Front deflector	1
12	14494	Cc holder	2

EU Declaration of Conformity



EU DECLARATION OF CONFORMITY

Description of Machine: Agricultural Pro-Series Fertilizer Spreader

Make / Model: Orchard Spreader
3T-2501
4T-3802
6T-5001
8T-6601
10T-8301

Serial Numbers: FOAA to FOZL 10150-99999

Name of Manufacturer: Giltrap Engineering Ltd.

Address: 7 North Main Road
Otorohanga
3900
New Zealand

We hereby declare that the product described above complies with all the relevant provisions of the Appropriate EU Directives and Harmonised standards of the European Union listed below, and accordingly carries CE-marking.

Machinery Directive 2006/42/EC

Date of Declaration: 17th November 2020 Date of Issue: 17th November 2020

Craig Mulgrew

Managing Director
Giltrap Engineering





We've assembled a comprehensive dealer network that knows what it takes to keep your Giltrap machinery in peak condition. With a blend of local knowledge and engineering expertise our team is here 24/7, so your business doesn't have to stop.

To find out more about our local dealer network or to discuss your specific needs, contact a member of our team.

NEW ZEALAND (HEAD OFFICE)
TEL +64 7 873 4199
EMAIL info@giltrapag.co.nz
giltrap.co.nz

AUSTRALIA
TEL +61 3 9369 6548
EMAIL sales@giltrapag.com.au
giltrapag.com.au

To find your local Giltrap and Duncan dealer visit:
<https://giltrapag.co.nz/nz/our-dealers>