

# Owners Manual

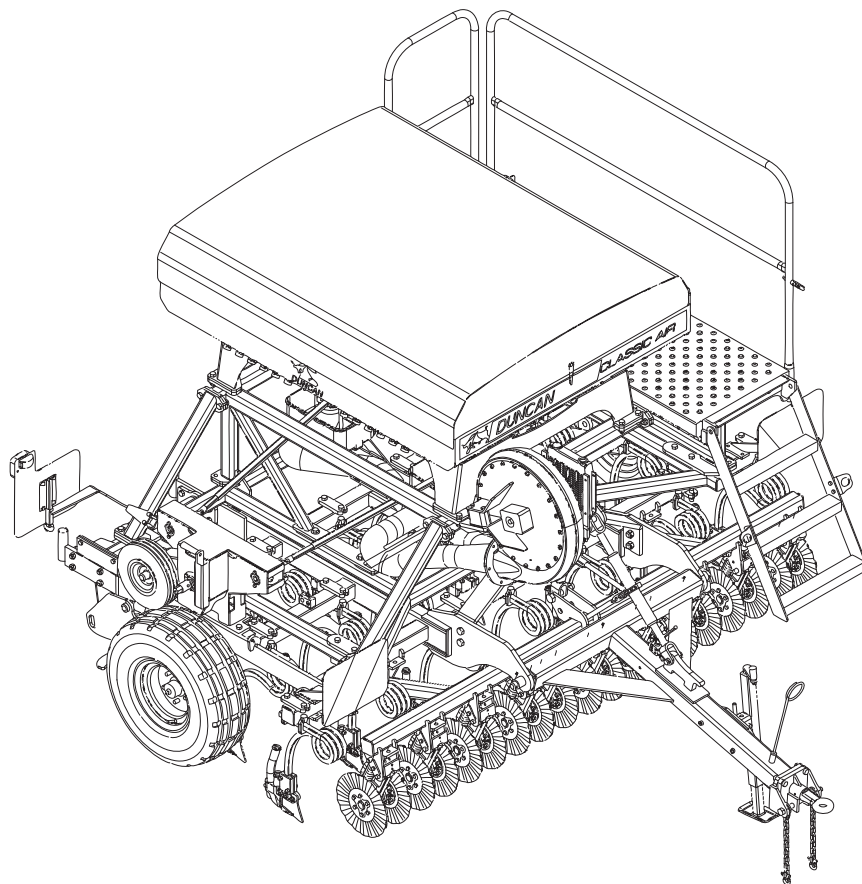

## Renovator Classic Air ORIGINAL INSTRUCTIONS



*Built to work.*

**Timaru Branch:**  
100 Hilton Highway, Washdyke,  
Timaru, New Zealand  
Tel: +64 3 688 2029  
Email: [timadmin@giltrapag.co.nz](mailto:timadmin@giltrapag.co.nz)  
Web: [www.giltrapag.co.nz](http://www.giltrapag.co.nz)

**Australian Branch:**  
105-117 Boundary Road,  
Laverton North, Melbourne,  
VIC 3026, Australia  
Tel: +61 3 9369 6548  
Email: [admin@giltrapag.com.au](mailto:admin@giltrapag.com.au)  
Web: [www.giltrapag.com.au](http://www.giltrapag.com.au)

**Pt. No. 67398  
Rev 0824**



# Renovator Classic Air Contents

	Page
<b>Introduction</b> .....	2
<b>Acquisition &amp; Warranty</b> .....	2
<b>Disclaimer</b> .....	2
<b>Description of Machine</b>	
Working Principle .....	3
<b>Specification</b>	
Dimensions & Capacities .....	5
<b>SAFETY - General</b>	
Safety Symbols on Machine .....	6
Operator Safety .....	7
Be Prepared for Emergencies .....	7
Appropriate Dress .....	8
Transport This Machine Safely .....	8
Handle Agricultural Chemicals Safely .....	9
Avoid High Pressure Fluids .....	9
Safe Work Practices .....	9
Practise Safe Maintenance .....	10
<b>SAFETY - Machine Specific</b>	
Hazard Points .....	11
Safety Decals & Safety Guards .....	13
<b>Transport</b> .....	14
<b>Setup, Calibration &amp; Operating Procedure</b>	
Read Before Operation .....	15
Pre-calibration setup flowchart .....	16
Calibration procedure .....	17
Hand Crank Turns for Seed Rate Calibration .	18
Calibration Deviations .....	19
19R Classic Sowing Chart .....	20
Airflow & Fan Speed .....	22
Operation .....	23
Depth Control .....	24
Farmscan Jackal Settings .....	25
Blank Page for your Calibration Notes .....	27
<b>Maintenance &amp; Care</b>	
General .....	28
Lubrication Instructions .....	29
Maintenance Schedule .....	30
Storage .....	32
Troubleshooting/Maintenance Notes .....	33
Commisioning/Troubleshooting Phasing Rams	34
<b>Parts List</b>	
Base Machine .....	39
Hose Connection Colours .....	71
Optional Extras .....	74

# Introduction

## Acquisition & Warranty

On delivery of your new Duncan Renovator Classic Air please check that the machine is not damaged. In cases of shipping damage, please ask your dealer to arrange for the appropriate claim to be lodged immediately. Assemble any parts supplied loose and inspect your machine with the aid of this manual to familiarise yourself with its features. If you have any queries ask your dealer straight away. The machine is covered by our 12 month warranty on faulty parts, subject to normal use.



**Record below the serial number of your machine and keep it in a secure place to help trace the machine and assist us when you order parts.**

## The Owner's Manual

<b>Model:</b> .....
<b>Serial No:</b> .....
<b>Owner:</b> .....
.....
.....
<b>Delivery Date:</b> .....
<b>Dealer:</b> .....
.....
.....

This Document contains the Original Operating Instructions for this machine and are verified by the Manufacturer.  
Signed:.....  
Product Development Manager

**Disclaimer**  
Every effort has been made to ensure that the information in this manual was accurate and up to date at the time of going to press. Giltrap AG reserves the right to make subsequent changes to the machine, where necessary, without notification.  
  
The Company will not be responsible for any damage or consequential loss arising out of misinterpretation or failure to follow recommended procedures. Nor will it be liable for any damage caused by or arising out of modification or misuse of its product.  
  
**The owner has a responsibility to protect himself and others by observing all safety information and by ensuring all operators are well acquainted with the safety information, trained in the correct use of the machine and applying safe work practices.**

Your new Duncan Renovator Classic Air will give long and efficient service if given normal care and operated properly.

This owner's manual is provided so that you can become thoroughly familiar with the design of the machine and to furnish information on correct operation, adjustment and maintenance. **Only persons well acquainted with these guidelines should be allowed to use the equipment.**

A separate illustrated parts section has been provided so that if any parts are required your dealer will be able to supply them by reference to part numbers.

The manual is considered as part of your machine and must remain with the machine when it is sold.

**Right and left hand references in this manual are determined by standing behind the machine and facing in the direction of travel.**



## Description of Machine

The Duncan 'Renovator Classic Air' is a Coil Tine T-boot drill. The large split hopper is mounted on a robust frame accommodating large diameter tyres.

Sowing depth is controlled by adjusting the hydraulic ram as required. The quality European air metering units handle all seeds from turnip and rape through to peas and maize and permits easy calibration. The seeders are driven via a jockey wheel with individually selected high or low ranges. For transport, the drive is easily disconnected by raising the drill to its transport height.

## Working Principle

The air flow and metering units are set to give the desired sowing and/or fertilizer rate. The coil tine and T-boot, create the seed bed. Seed flows down the flexible tubes between seeder and tee-boot units, and drops into the prepared seed bed. Optional tine harrows and following roller enhance seed to soil contact.

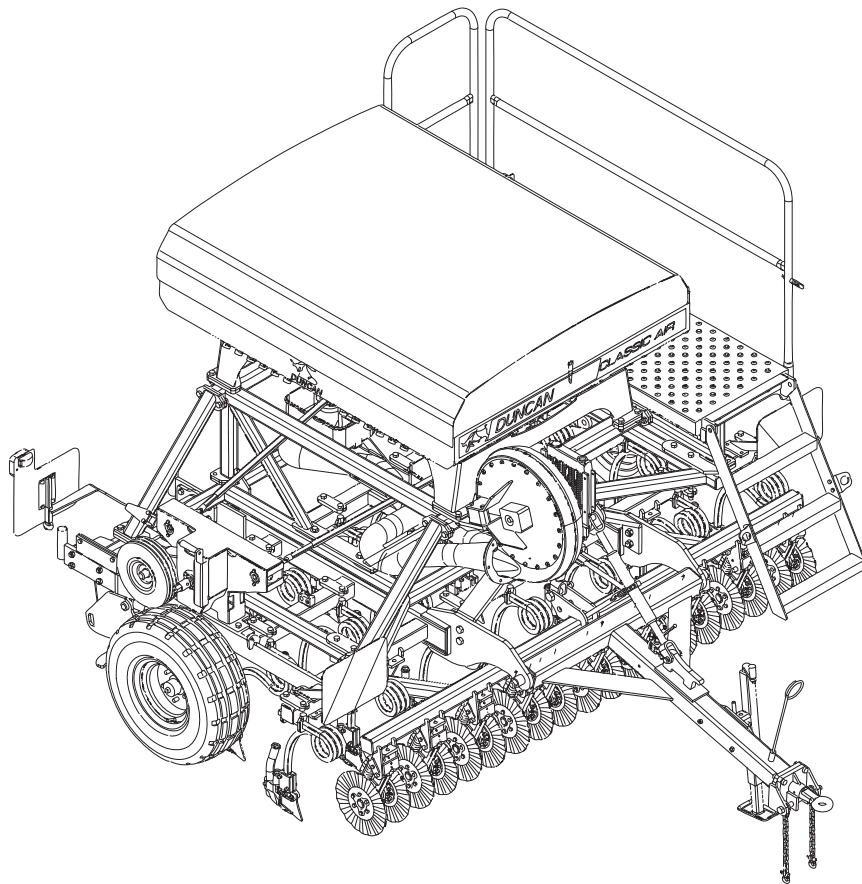

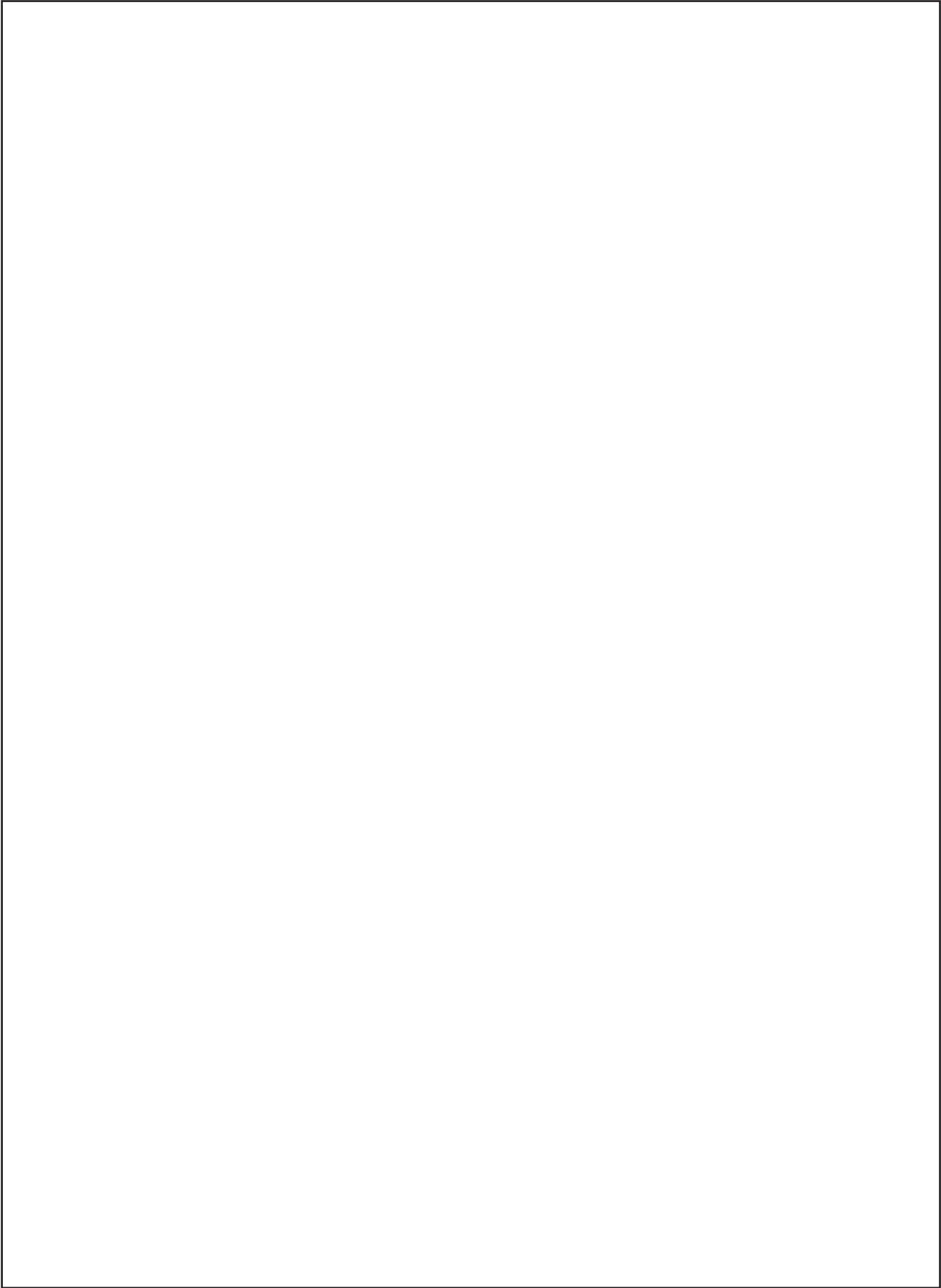

## Dimensions & Capacities

Dimensions & Capacities	
Width (over wheels /mm)	3026
Height (Groundwheels up /mm)	2320
Height (Groundwheels down /mm)	2665
Overall Length (mm)	3500
Tyre Size	10/80/12
Recommended Tyre Pressure	4 Bar (58psi)
Maximum speed (km/hr)	30 km/hr
Jockey Tyre Size	410/350 x 6 x 4 ply
Jockey Tyre Pressure*	3.44 Bar (50 psi) - TYRE IS FILLED WITH ANTI-PUNCTURE SEALANT*
Row Spacing	147.5
Effective Sowing Width	2802.5
Box Capacity (litres per box)	700
Tractor HP Rating Range	110 to 180

\*Pressure gauges may be damaged if they are not filtered

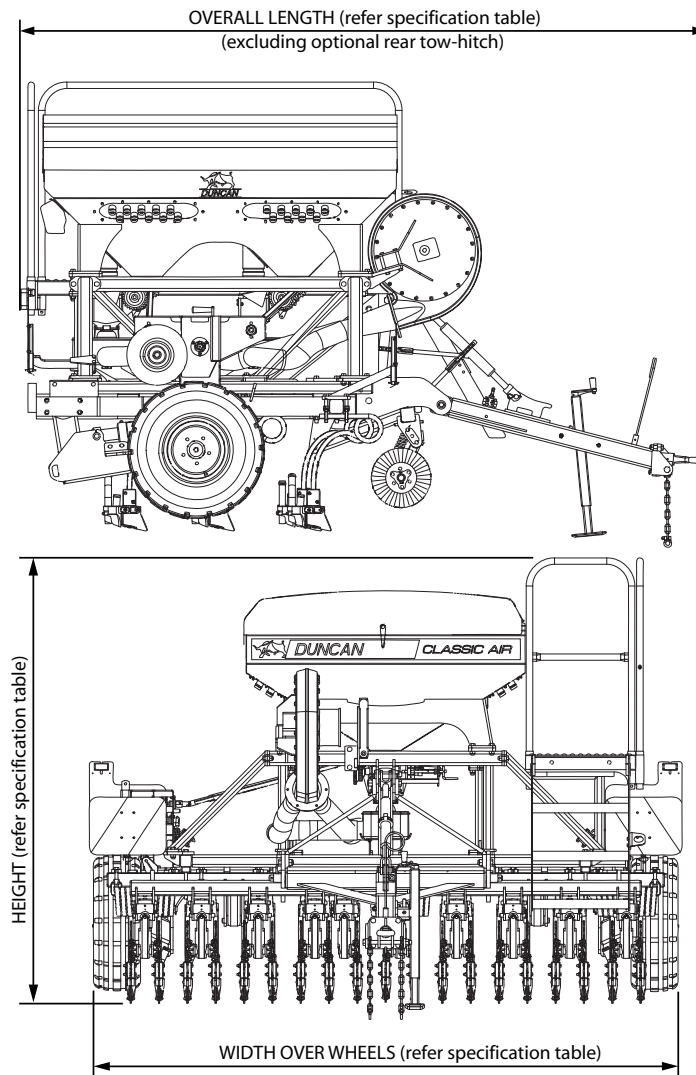

# 'Renovator Classic Air' Safety



## ATTENTION

On the machine important safety information is indicated by these symbols. These highlight general safety aspects in regard to the machine rather than specific hazards.



**Do not ride or allow passengers on the machine.**

Under no circumstances are passengers to be permitted on the machine while it is in operation or being transported. Any footboards and/or footsteps are provided solely for the purpose of preparing the machine for use.



**Pinch Points  
Moving Parts**

**Keep clothing and body extremities well clear of pinch points while the machine is operating (seeding or calibrating). Keep well clear of moving parts at all times.**

These signs typically occur wherever trapping points exist. These include drive chains, sprockets, shafts, wheels, discs, pivot points, etc. Guards are provided with the machine for safety reasons (where practical without compromising machine performance). Ensure these are always fitted during operation.



**Sharp  
Points**

**Always exercise extreme caution in the vicinity of sharp edges and points.**

Where possible guards are provided with the machine for safety reasons (where practical without compromising machine performance). Ensure these are always fitted during operation.



**Slippery  
When  
Wet**

**Footboards, footsteps, drawbars and other machine surfaces may be slippery when wet.**

Apply extra caution in wet conditions and in the early morning when surfaces are wet.

**KEEP CLEAR**

**Keep Clear. (It is dangerous to be in this area when the machine is operating.)**



# 'Renovator Classic Air' Safety

## SAFETY - General

**N.B. Throughout this manual important safety information is indicated by these symbols in the margin:**



**A prohibition** should be observed under all circumstances.



**A warning** indicates a hazard that could cause death or injury if the warning is ignored.



**A caution** indicates a hazard that may cause damage to property if the caution is ignored.

**This section of the manual offers general guidelines for the safe operation of machinery.** It does not replace local safety regulations. These guidelines were current at the time of publication, but may be superseded by later regulations.

Giltrap AG has made every effort to highlight all risks to personnel or property. Owners and operators have a responsibility to exercise care and safe work practices at all times in the vicinity of the machine.

Owners are advised to keep up to date on safety issues and to communicate these to all users of the machine.

Contact the Occupational Safety and Health Service (OSH) for further information about general safety aspects. If you have safety concerns specifically related to this machine, contact your dealer immediately.

### Operator Safety

Read this manual carefully before operating new equipment. Learn how to use this machine safely. Be thoroughly familiar with the controls and the proper use of the equipment before using it.

Take careful note of all safety instructions both in this manual and on the machine itself. Failure to comply with instructions could result in personal injury and/or damage to the machine.

Replace missing or damaged safety signs on the machine and ensure that these remain clearly visible.

**It is the owner's responsibility to ensure that anyone who operates, adjusts, lubricates, maintains, cleans or uses the machine in any way has had suitable instruction and is familiar with the information in this manual (particularly with regard to safety aspects).**

**Operators and other users of the machine should be aware of potential hazards and operating limitations.**

### Be Prepared for Emergencies

Keep a first aid kit and fire extinguisher handy.

Keep emergency numbers for doctors, ambulance, hospital and fire department near your telephone.



# 'Renovator Classic Air' Safety

## SAFETY - General (Continued)



### Appropriate Dress

Wear close fitting clothing and avoid rings or other forms of jewellery which could become caught in the machinery.

People with long hair must have it securely fixed and confined close to the head.

Refer to local safety standards for protective clothing and recommended safety equipment.

Adequate protection, such as a face mask, should be worn if operating this machine in dry and dusty conditions.



### Transport This Machine Safely

Ensure that all linkage pins and security clips are fitted correctly. With trailing machines tow with the drawbar only, as this is the only safe towing point on the machine.

Always check that bystanders (especially children) are well clear (front and rear) before starting and moving the tractor and the machine.

Plan safe routes of travel, and be aware of power lines and other roadside hazards. Take particular care when towing implements on hillsides.

### Do not ride or allow passengers on the machine.

This machine is not designed to carry passengers, and no riders are permitted.



### Road transport

On public roads,

- A speed of 40km/h must not be exceeded.
- Do not operate during the hours of darkness unless standard lights are fitted and clearly visible. (This also applies when visibility is limited, e.g., in foggy conditions.)

See the guidelines in the *Vehicle Dimensions and Mass Rule*, issued by the Land & Transport Safety Authority.

### Avoid tip-overs

Avoid holes, ditches and obstructions which may cause the machine to tip over, especially on hillsides. Never drive near the edge of a gully or steep embankment - it might cave in. Slow down for hillsides, rough ground and sharp turns.



# 'Renovator Classic Air' Safety

## SAFETY - General (Continued)

### Handle Agricultural Chemicals Safely

All farm chemicals should be stored, used, handled and disposed of safely and in accordance with the supplier's/manufacturer's recommendations.



**Read the product label before using, noting any warnings or special cautions, including any protective clothing or equipment that may be required, ie. respirator.**

Do not eat or smoke while handling sprays, fertilisers, coated seeds, etc. Afterwards, always wash your hands and face before you eat, drink, smoke, or use the toilet.



Store sprays, fertilisers, coated seeds, etc. out of reach of children and pets, and away from food and animal feeds.

Any symptoms of illness during or after using chemicals should be treated according to the supplier's/manufacturer's recommendations. If severe, **call a physician or get the patient to hospital immediately.** Keep the container and/or label for reference.

### Avoid High Pressure Fluids

Avoid any contact with fluids leaking under pressure, because the fluids can penetrate the skin surface.



Any fluid which penetrates the skin, will need to be **removed immediately by a medical expert.** Seek specialist advice on this type of injury.

Relieve the pressure before disconnecting any hydraulic or other lines. Make all repairs and tighten all fittings before re-connection to pressurised fluid.

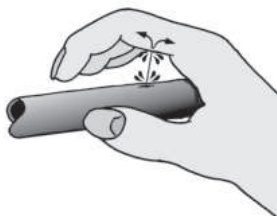

Keep your hands and body away from any pinholes or high pressure jets. Search for leaks with a piece of cardboard instead of using your hand directly.

### Safe Work Practices

All farm machinery is potentially dangerous and should be treated with caution and respect.

Before starting the machine, ensure that all controls are placed in neutral and that bystanders are well clear. Check that the guards have been securely fitted and that any adjustments have been made correctly.



Where possible, disconnect or isolate the drive mechanism to the implement. Lower the machine onto the ground when not in use.

Do not operate this equipment when severe weather conditions appear imminent.

# 'Renovator Classic Air' Safety

## SAFETY - General (Continued)



### Practice Safe Maintenance

Keep the machine in safe working condition. Routine maintenance and regular servicing will help reduce risks and prolong the life of the machine.

### General Maintenance

Accidents occur most frequently during servicing and repair. The following general rules must be followed when maintaining or working with machinery:

- All operating and maintenance manuals must be read before and referred to while using or servicing any piece of equipment.
- Turn off all machinery power sources and isolate the machine before making adjustments, doing lubrication, repairs or any other maintenance on the machine.
- Ensure that the machine hydraulics are disconnected from the power source.
- Wear gloves when handling components with cutting edges, such as any ground cutting components.
- Beware of the following hazards when dismantling or maintaining the machine:-
  - > Hydraulics under pressure
  - > Springs under tension or compression
- It is recommended that you clean the machine with a water blaster or similar apparatus before commencing maintenance.



### Make Sure the Machine is Well Supported

When machinery is fitted with hydraulics, do not rely on the hydraulics to support the machine. During maintenance or while making adjustments under the machine, always lock the hydraulics and support the machine securely. Place blocks or other stable supports under elevated parts before working on these.

### Electrical Maintenance

Disconnect the electrical supply from the tractor before doing any electrical maintenance.



### Welding

With electronic equipment in modern tractors it is advisable to disconnect the machine from the tractor, or at least disconnect the alternator and battery before attempting any welding.



### Use Only Genuine Spare Parts

Unauthorised modifications or non-genuine spare parts may be hazardous and impair the safe operation and working life of the machine.

Excess lubricants must be disposed of safely so as not to become a hazard.

# 'Renovator Classic Air' Safety

## SAFETY - Machine Specific

This section of the manual gives specific guidelines for the safe operation of the Renovator Classic Air.

These guidelines were current at the time of publication, but may be superseded by later circumstances. They do not necessarily cover every possible hazard and must be read in conjunction with the **SAFETY - General** section (Page 7 to 10).

### Hazard Points on the Renovator Classic Air



The lists below are not all-inclusive and serve only to highlight the more obvious areas of risk.

The decals attached to the machine are a general reminder that there are hazardous areas on the machine, rather than specifically highlighting all possible hazards.

**For decal locations on machine, refer Page 13.**



#### No Ride

Passengers are not permitted anywhere on the machine.



#### Pinch Points/Moving Parts

Hazardous areas include:

- Drive chains.
- Sprockets between the jockey wheel, the transfer shaft and the output shaft.
- Universal joints and drive shafts
- Seed Metering units, box shaft and shaft connectors.
- Wheel legs and main frame assemblies
- Between discs and other sub-assembly parts (where fitted).
- Finger tine assemblies (where fitted).
- Hydraulic Fan.
- Row Markers.



Slippery  
When  
Wet

#### Slippery When Wet

Hazardous areas include:

- Footboards and footstep.
- All smooth surfaces on the frame structure.

**KEEP CLEAR**

#### Keep Clear

Hazardous areas include:

- Between the tractor and the Renovator Classic Air.
- Immediately adjacent to the Renovator Classic Air side.

# 'Renovator Classic Air' Safety

## SAFETY - Machine Specific (Continued)



### Hazard Points on the Renovator Classic Air (Continued)

For guard locations on machine, refer Page 13.



### Transport

The two wheels located at the sides of the machine are for the purpose of controlling sowing depth. These are also used to support the machine weight during transport (while linked to the tractor).

**Important** - Refer to safety cautions in the **Transport** section, page 14 of the manual. Ensure that all linkage pins and security clips are fitted correctly.

### Maintenance

Refer Page 38 for reference to the **Maintenance and Care** section of the manual.

### Lubrication

Refer Page 39 for reference to the **Maintenance and Care** section of the manual.

# 'Renovator Classic Air' Safety

## SAFETY - Machine Specific (Continued)

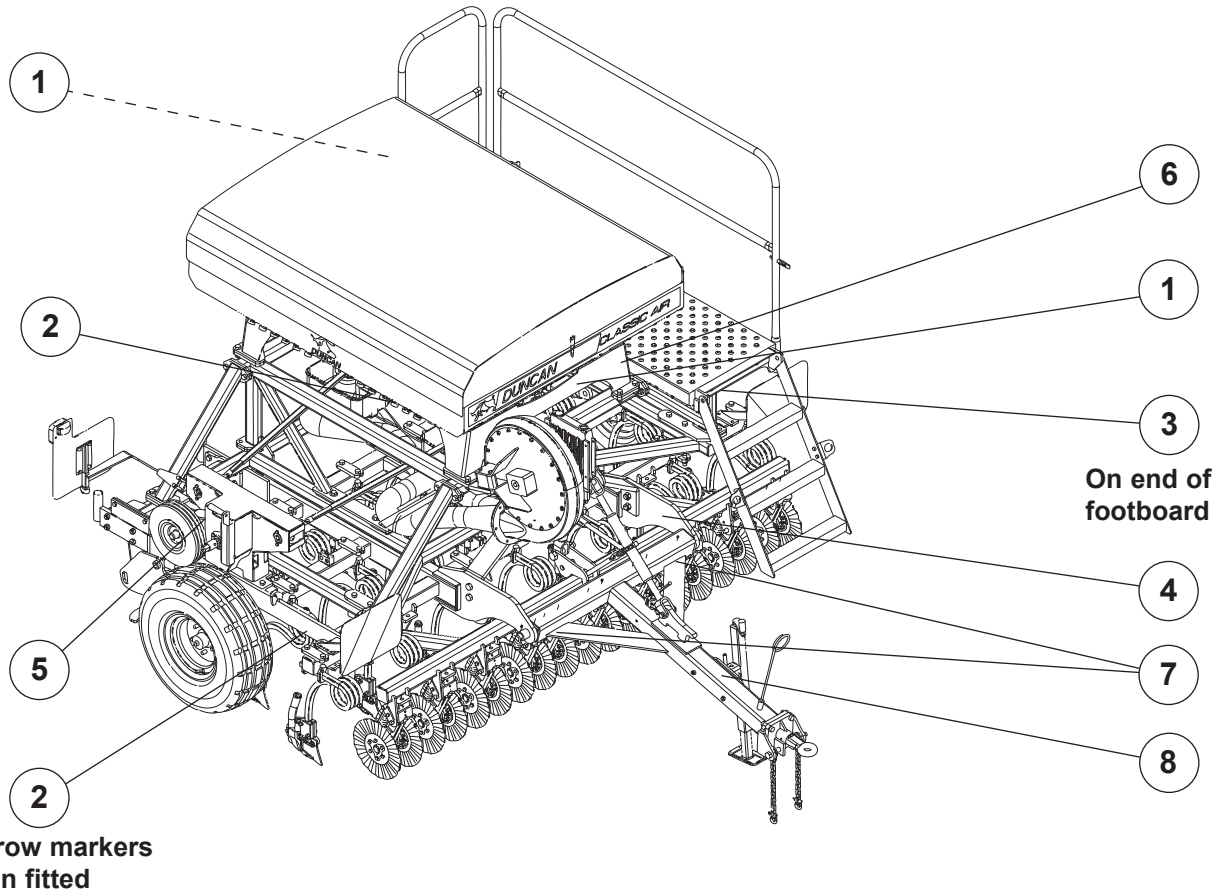

Item	Decal/Guard	Pt. No.	Qty
1	'No Ride'	43900	3
2	'Pinch Point/Moving Parts'	43901	5
3	'Slippery When Wet'	43902	2
4	'Keep Clear'	43904	2
5	Jockey Drive Swing Guard	25745	1
6	'30 km/hr'	43911	2
7	'Lift Point'	14389	2
8	'Hose Connection Colours'	72818	1



# 'Renovator Classic Air' Transport

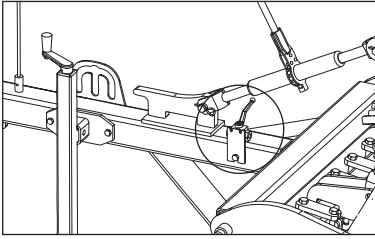

## Transport

1 Raise the drill into the transport position and hold at the full extent of the rams for a few seconds to allow cylinders to rephase/equalise.

2 **Important** - To avoid machine damage due to drill lowering during transport, always close the hydraulic valve on the drawbar. Move the handle to a position at 90° to the hydraulic line. This applies to the drawbar and disc opener hydraulic valves where fitted.

3 Locate jack stand in transport position, if fitted.

4 Ensure lighting and oversize warning requirements meet recommendations published by the local Land Transport Authority or equivalent.

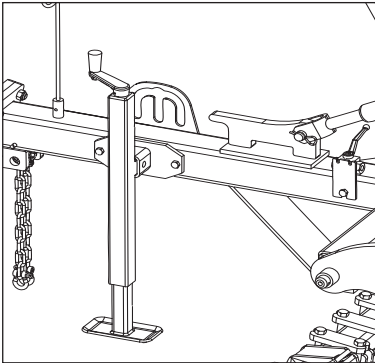

5 **Maximum towing speed 30 km/hr.** For countries other than New Zealand other speed restrictions may apply, please refer to your local transport authority.

Ensure towing vehicle requirements are adequate for the towed vehicle e.g. mass, brakes. Refer to recommendations published by the local Land Transport Authority or equivalent.

Braking when towing can cause the load to jackknife. Use extra care when towing in adverse conditions such as mud, inclines and sharp bends.

Lower towing speeds are recommended on farm roads/tracks and where one wheel is on or over a road verge.

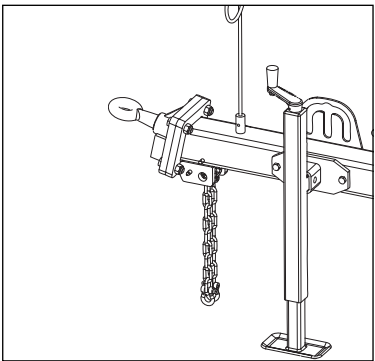

6 **Attach safety chains to tractor.** Refer Fig 3. Safety chains must be crossed over underneath the coupling and attached to the towing vehicle. The attachment points must be as close as practical to the towing coupling and one each side. The towbar on the towing vehicle must be rated for the towed mass. **Do not remove or replace the safety chains provided with any other than those specified in the parts manual.**

**Note:** The safety chains are provided with sufficient length to cater for all towing vehicles. Safety chains must be shortened by cutting off excess length so that if the coupling fails the drawbar will not hit the ground.

7 If the machine is fitted with row markers or other vertical extensions, check clearance under power lines en route.

8 **Important** - For greater disc opener ground clearance, adjust the ram or turnbuckle on the disc opener unit so they are at maximum height, and/or extend the drawbar ram or turnbuckle to level the machine chassis.





# 'Renovator Classic Air' Read Before Operation

## Components Referred to in the Pre-Calibration Setup and Calibration Process

The following pages describe how to set the machine up for calibration, the calibration process and subsequent adjustments to obtain the desired seed and/or fertilizer output.

Terms and words used in those instructions are shown below:-

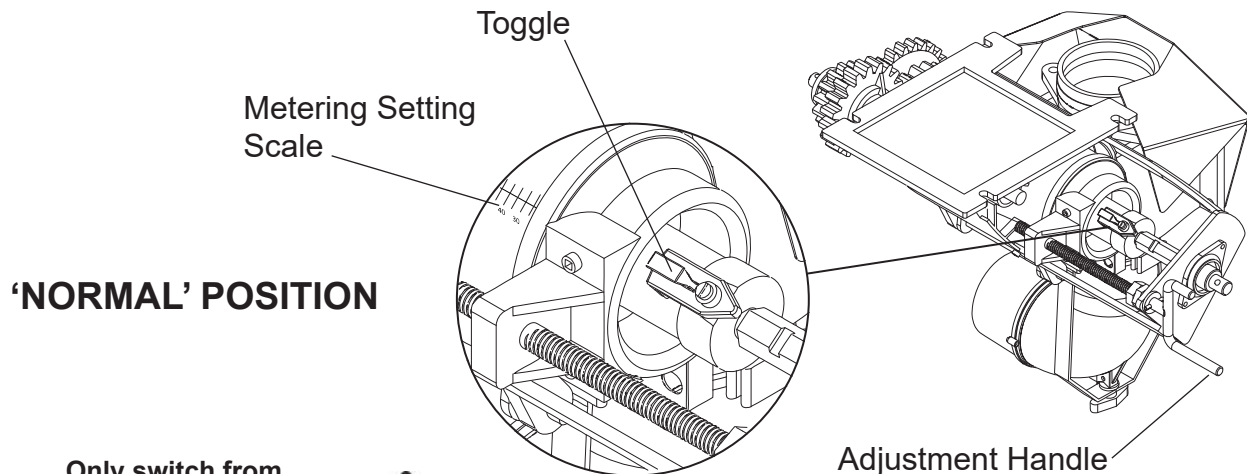

Only switch from normal to fine seed if the seed hopper is empty

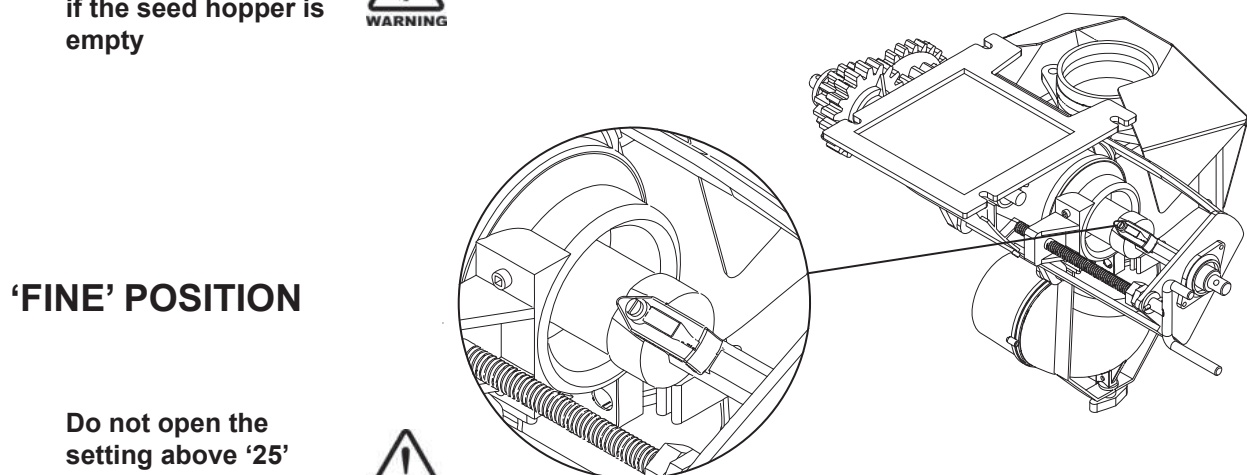

Do not open the setting above '25' with the toggle set to 'fine' as the adjuster will break.

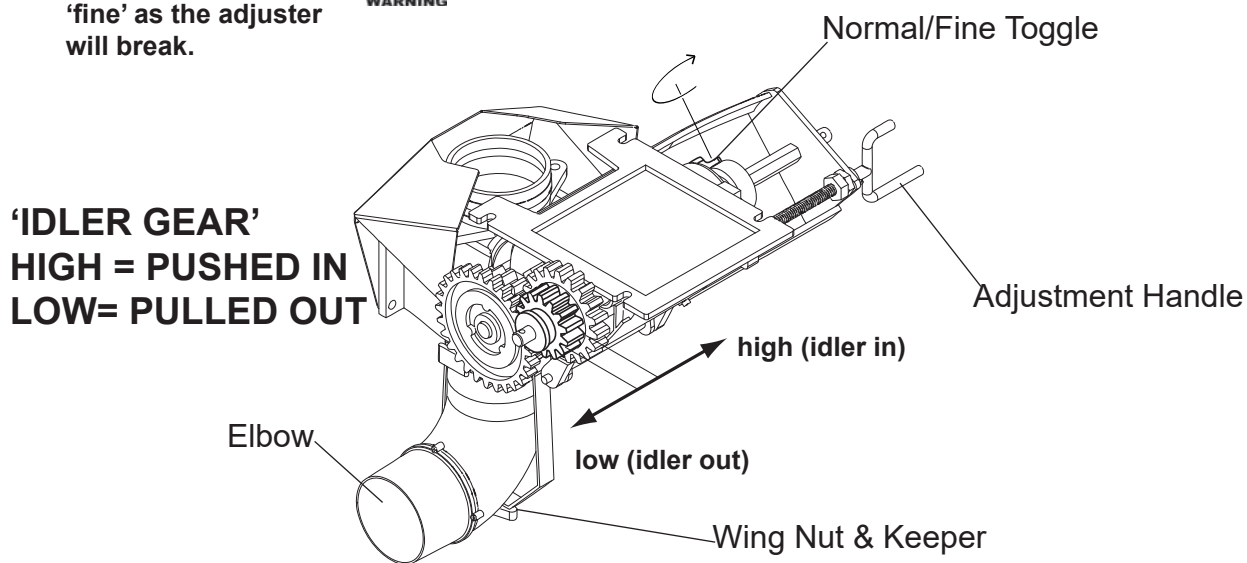

# 'Renovator Classic Air' Pre-Calibration Setup

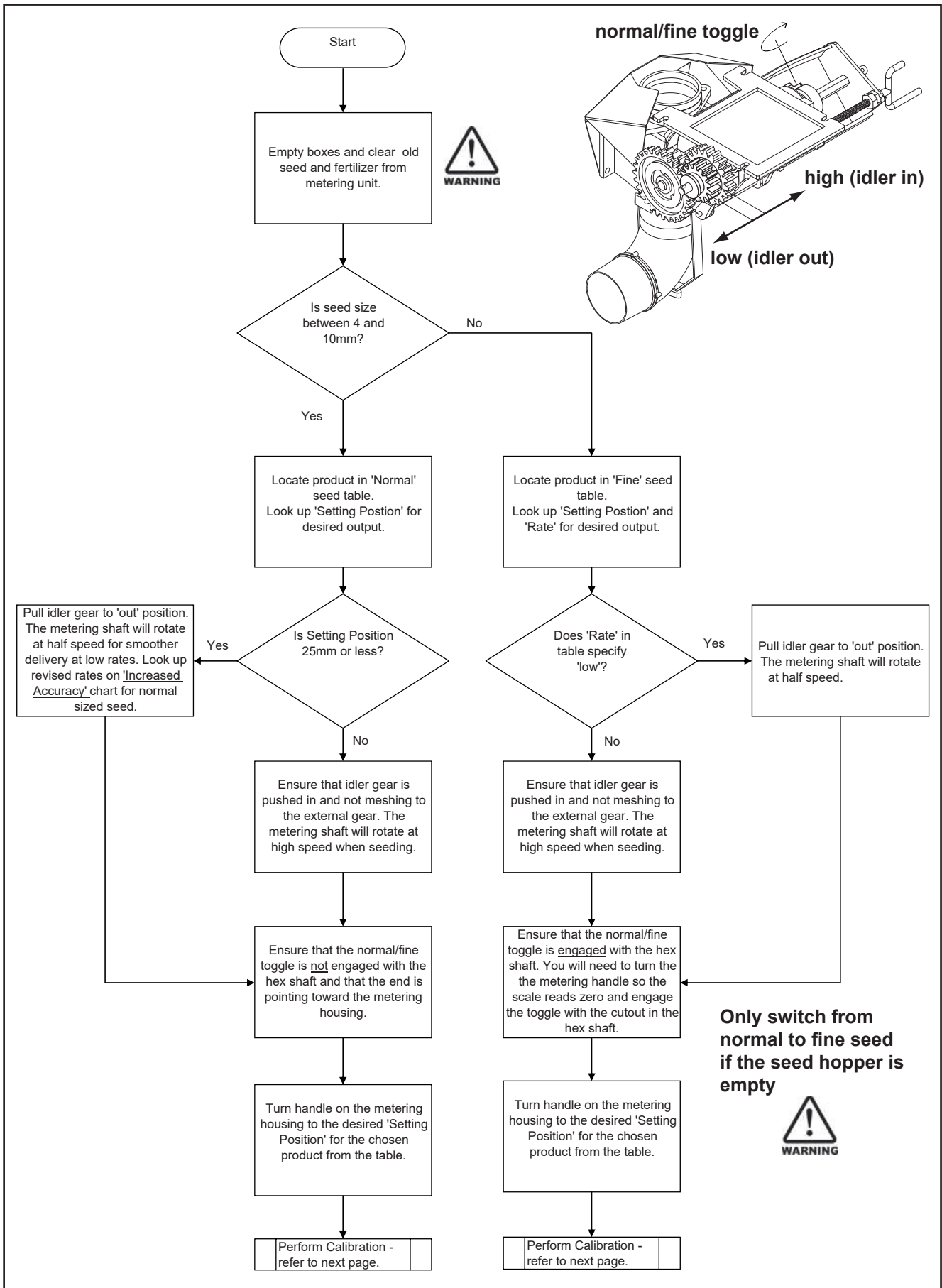

# 'Renovator Classic Air' calibration

## Seed Calibration

The calibration test should be done to confirm the settings of the required seed rate and is done with the drill stationary and level with the fan off.



The metering units must be set prior to filling with seed.

## Seed Calibration Procedures

- 1 Ensure that the metering unit is free from debris. Close the trap-door.
- 2 Fill the appropriate bin. A minimum depth of 300mm is required for calibration with normal seeds.
- 3 Release the elbows from under the metering housings by unscrewing the wing nut and swinging the keeper out of the way. Move the elbow to one side.
- 4 Unhook the calibration tray from the rear of the machine, locate it on the guides and slide the tray under the bin outlets.
- 5 The bins are calibrated one-at-a-time; on the drive pedestal (outboard) end, remove the lynch pin and disconnect the unused driveshaft. Attach the end to the dummy shaft provided on the pedestal.
- 6 Place the crank handle over the hexagonal drive dog turn anti-clockwise until the seed flows consistently. To ensure complete filling of the seed unit continue turning the crank until an even flow of seed is coming out of the seeder units, then empty into the seedbox. The drill is now ready for calibration.
- 8 Refer to the table on the next page and turn the crank handle anticlockwise the number of turns for your machine. Crank at a steady rate of 1.5 seconds per revolution of the handle.

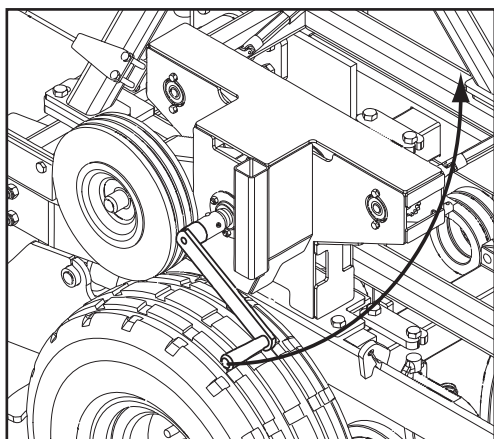

**Note** The Calibration is usually done for 1/40th Hectare. For very small seed rates or when using inaccurate scales (i.e. unable to measure to the nearest gram) the calculation based on 1/10th hectare should be used. ie: In the case of a 19R 3.0m machine, turn the crank handle 130 turns.

**Scales must be accurate to 2 grams as any error will be multiplied by either 10 or 40 giving inaccurate calibration results.**

For  $\frac{1}{40}$  Hectare (250m<sup>2</sup>) Calibration  
Seed Rate = Actual Seed Collected (kg) x 40

For  $\frac{1}{10}$  Hectare (1000m<sup>2</sup>) Calibration  
Seed Rate = Actual Seed Collected (kg) x 10

# 'Renovator Classic Air' Calibration

## Hand Crank Turns for Seed Rate Calibration

Machine Size	Row Spacing(mm)	Sowing Width (m)	Turns for 1/40 Hectare	Turns for 1/10 Hectare
19 Run	147.5	2.80	32.5	130

- 9 Weigh the seed collected during the test in kilograms.

**Caution:** Scales must be accurate to 2 grams, as any error will be multiplied by either 10 or 40, giving inaccurate calibration results.

- 10 Calculate the seed rate by multiplying the kgs previously collected x 40 (1/40th ha method) or x 10 (1/10th ha method) depending on the requirement.

The seed rate should be correct. Large differences should be checked by recalibration. If there are still large errors, empty the seed bin, check the metering housings for wear or damage and start again from the pre-calibration setup.

- 11 Small errors, due to seed coatings or seed sizes may be corrected by adjusting the metering unit as follows:-

>Check and write down the **actual metering setting** on the metering unit.

>Write down the **actual seeding rate** that you calculated.

>Write down the **required seeding rate** (the number you *expected* from the calculation).

Calculate the error and correction as follows:-

$$\text{error} = \frac{\text{difference between actual and required seeding rate}}{\text{required seeding rate}}$$

$$\text{correction} = \text{error} \times \text{actual seeding rate}$$

- 12 If the **actual seeding rate** that you calculated is **smaller than** the **required seeding rate** then **increase** the metering setting by the **correction** amount.

- 13 Conversely, **reduce** the **metering setting** by the **correction** amount if the observed or **actual seeding rate** is **more than** the **required seeding rate**.

**Care must be taken when the metering setting is significantly reduced as the unit can be damaged. If any resistance is felt, rotate the jockey wheel when adjusting the settings down. If the toggle is set to 'fine' and the settings needs to be reduced very low, empty the bin and start again.**



- 14 Recalibrate from step 6.

- 15 Where a coated seed is used it is advisable to check the calibration after 1 hectare as dressings can tend to create a coating on the seed metering wheels thus changing the the flowing properties of the seed which in turn alters the seed rate.

# 'Renovator Classic Air' Calibration

## Wheel Slip Deviations

It is always possible with rubber tyred drills in extreme ground conditions to get wheel slip. Not normally a problem with cleated type tyres in good condition, but more so in the arable situation with the less aggressive tread patterns. The result: large differences between the calibration test and the actual sowing rate, obviously less seed deposited than required.

## To check number of crank turns for calibration

Should you require to check this in a practical way proceed as follows:

**For an area of 250m<sup>2</sup> (1/40 Hectare), the travel distance for your machine is shown below:-**

Machine Size	Row Spacing (mm)	Travel Distance for 1/40Ha (metres)
19 Run	147.5	89.2

Place the crank handle over the hexagonal drive dog on the gearbox.

Move the machine forward over the measured distance, counting the number of turns of the crank handle as you go.

Using this number of crank turns repeat the calibration.

# '19 Run Classic Air' Sowing Chart Normal

## 19 Run Classic

NORMAL SEED (toggle NORMAL, Butterfly Valve Settings shown below and on page 22)

PRODUCT	SPECIFIC GRAVITY (kg/l)	Setting Position> RATE*	*10*	*15*	*20*	*25*	30	35	40	45	50	55	60	65	70	75	80	85	90	95	100	105	110
Wheat	0.8	high	35	52	70	87	106	124	142	159	177	195	213	232	250	268	285	303	321	340	358	376	393
Oats	0.5	high	24	36	48	60	72	83	95	108	120	132	143	155	168	180	192	203	215	228	240	252	264
Barley	0.7	high	33	49	65	80	96	113	129	145	161	177	193	209	225	242	257	272	288	305	321	337	353
Ryecorn	0.7	high	34	50	67	84	102	119	136	153	171	187	203	220	239	256	273	290	307	324	342	360	377
Peas	0.8	high	21	41	60	79	99	119	138	157	177	197	216	236	255	274	294	314	333	352	372	391	410
Grass	0.4	high	-	18	26	35	43	51	-	-	-	-	-	-	-	-	-	-	-	-	-	-	-
Pasture Mix	-	high	-	18	26	35	43	51	-	-	-	-	-	-	-	-	-	-	-	-	-	-	-
DAP	1.0	high	40	59	78	99	118	137	157	177	196	216	236	255	274	295	314	333	353	373	392	412	432
Superphosphate	1.3	high	35	71	111	140	174	207	239	270	308	341	372	396	428	458	497	532	567	595	632	670	-

INCREASED ACCURACY FOR SETTING POSITION<25mm (toggle NORMAL, Butterfly Valve Settings shown below and on page 22)

PRODUCT	SPECIFIC GRAVITY (kg/l)	Setting Position> RATE*	*10*	*15*	*20*	*25*	30
Wheat	0.8	low	17.3	25.9	35.0	43.7	52.8
Oats	0.5	low	12.2	17.8	23.9	30.0	36.1
Barley	0.7	low	16.3	24.4	32.5	40.1	48.2
Ryecorn	0.7	low	16.8	24.9	33.5	42.1	50.8
Peas	0.8	low	10.7	20.3	30.0	39.6	49.3
Grass	0.4	low	-	9.1	13.2	17.3	21.3
Pasture Mix	-	low	-	9.1	13.2	17.3	21.3

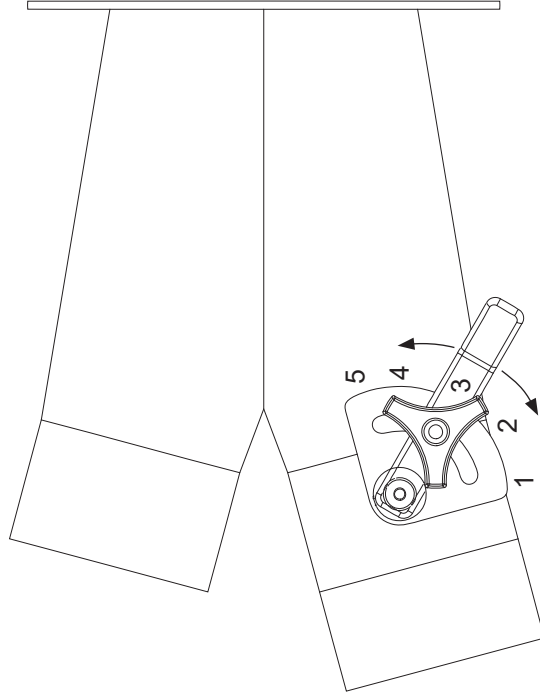

Box contents		Butterfly Position (affects rear box)		Fan Speed/rpm*
FRONT	REAR	open	closed	
seed (Normal)	seed (Normal)	open - 5	closed - 1	3000
seed (Normal)	seed (Fine)	closed - 1		3000
Fertilizer	seed (Normal)	closed - 2		3000 to 3500
Fertilizer	seed (Fine)	closed - 1		3000 to 3500

\*MAXIMUM PERMISSIBLE SPEED 4000 RPM

# '19 Run Classic Air' Sowing Chart Fine

FINE SEED (toggle 'FINE', Butterfly Valve Settings shown below and on page 22)

## 19R Classic

PRODUCT	SPECIFIC GRAVITY (kg/l)	Setting Position>	2.5	5	7.5	10	12.5	15	17.5	20	22.5	25
			RATE ONCE SET DO NOT REDUCE/CLOSE WITH SEED IN BIN**									
Lucerne (Alfalfa)	0.8	low	1.1	3.1	4.7	6.6	8.1	9.5	11.5	13.2	14.6	15.7
Turnip	0.7	low	1.1	2.3	3.5	4.6	5.8	7.0	8.1	9.2	10.4	11.6
Kale	0.7	low	1.1	2.3	3.5	4.6	5.8	7.0	8.1	9.2	10.4	11.6
Swedes	0.7	low	1.1	2.3	3.5	4.6	5.8	7.0	8.1	9.2	10.4	11.6
Canola/Rape	0.7	low	1.1	2.3	3.5	4.6	5.8	7.0	8.1	9.2	10.4	11.6
White Clover	0.8	low	1.2	2.7	4.4	6.1	7.8	9.1	10.8	12.2	13.5	14.0
Red Clover	0.8	low	1.2	2.7	4.4	6.1	7.8	9.1	10.8	12.2	13.5	14.0
Grass	0.4	low			1.4	2.6	3.7	4.7	5.7	6.7	7.6	8.2
Millet	0.6	low		1.1	2.3	3.7	4.9	5.9	6.9	8.3	9.3	10.5
Grain Sorghum	0.6	low		0.3	2.8	6.1	7.6	8.6	10.7	12.4	13.9	15.9
Forage Sorghum	0.6	low		0.3	2.8	6.1	7.6	8.6	10.7	12.4	13.9	15.9
Chicory	0.5	low	0.6	1.9	2.9	4.1	5.1	6.3	7.6	8.7	9.7	10.6
Lucerne (Alfalfa)	0.8	high	2.2	6.2	9.3	13.2	16.1	19.0	22.9	26.3	29.2	31.5
Turnip	0.7	high	2.2	4.7	6.9	9.2	11.6	13.9	16.1	18.5	20.8	23.2
Kale	0.7	high	2.2	4.7	6.9	9.2	11.6	13.9	16.1	18.5	20.8	23.2
Swedes	0.7	high	2.2	4.7	6.9	9.2	11.6	13.9	16.1	18.5	20.8	23.2
Canola/Rape	0.7	high	2.2	4.7	6.9	9.2	11.6	13.9	16.1	18.5	20.8	23.2
White Clover	0.8	high	2.3	5.4	8.7	12.2	15.5	18.3	21.6	24.4	27.0	27.9
Red Clover	0.8	high	2.3	5.4	8.7	12.2	15.5	18.3	21.6	24.4	27.0	27.9
Grass	0.4	high			2.8	5.3	7.3	9.3	11.4	13.4	15.2	16.5
Millet	0.6	high		2.3	4.7	7.4	9.8	11.8	13.8	16.7	18.7	20.9
Grain Sorghum	0.6	high		0.7	5.7	12.2	15.2	17.3	21.3	24.8	27.8	31.9
Forage Sorghum	0.6	high		0.7	5.7	12.2	15.2	17.3	21.3	24.8	27.8	31.9
Chicory	0.5	high	1.2	3.7	5.9	8.3	10.3	12.7	15.3	17.5	19.4	21.1

\*\*Setting may only be reduced by a large amount if unit is turning or bin and metering device clear of product else damage will occur. Do not open the setting above '25' with the toggle set to 'fine' as the adjuster will break.

Box contents		Butterfly Position (affects rear box)	Fan Speed/rpm*
FRONT	REAR		
seed (Normal)	seed (Normal)	open - 5	3000
seed (Normal)	seed (Fine)	closed - 1	3000
Fertilizer	seed (Normal)	closed -2	3000 to 3500
Fertilizer	seed (Fine)	closed - 1	3000 to 3500

\* MAXIMUM PERMISSABLE FAN SPEED 4000 RPM



# 'Renovator Classic Air' Airflow & Fan Speed

## Airflow and Fan Settings

1. Hydraulic Fan -connect the hoses in the following order:

First - connect Zero pressure Case Drain 3/8" hose (1/2" BSP Female QR) to hydraulic reservoir \* Hose marked with short RED wrap.



Second -connect Motor Return 3/4" hose (3/4" BSP Female QR) to tractor high flow low pressure return port. Hose marked with medium length RED wrap.

Finally - connect High Pressure Motor Feed 1/2" hose (1/2" BSP Male QR) to tractor remote. Hose marked with long RED wrap.

Disconnect in the reverse order to prevent motor seal damage.

\*The tractor hydraulic reservoir or free drain connection must have zero backpressure.



2. A higher fan speed is usually required to correctly deliver high rate or heavier product such as fertilizer from the front box. The airflow to the rear box is reduced by setting the butterfly valve to the appropriate position as shown in the table. If this is not done the seed delivered to the disc units from the rear box may well bounce out of the seed slot.

The following table shows box fill combinations, butterfly position and recommended fan speeds for normal/fine seeds and fertilizer:-

Box contents		Butterfly Position (affects rear box)	Fan Speed/rpm*
FRONT	REAR		
seed (Normal)	seed (Normal)	open - 5	3000
seed (Normal)	seed (Fine)	closed - 1	3000
Fertilizer	seed (Normal)	closed -2	3000 to 3500
Fertilizer	seed (Fine)	closed - 1	3000 to 3500

\* MAXIMUM  
PERMISSABLE  
FAN SPEED  
4000 RPM

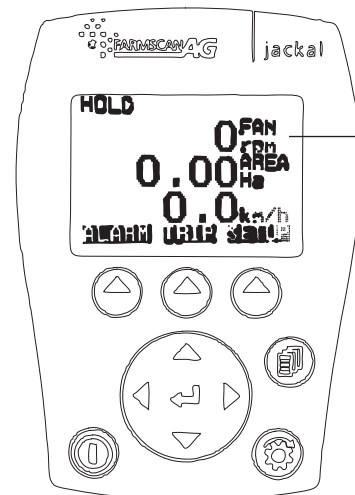
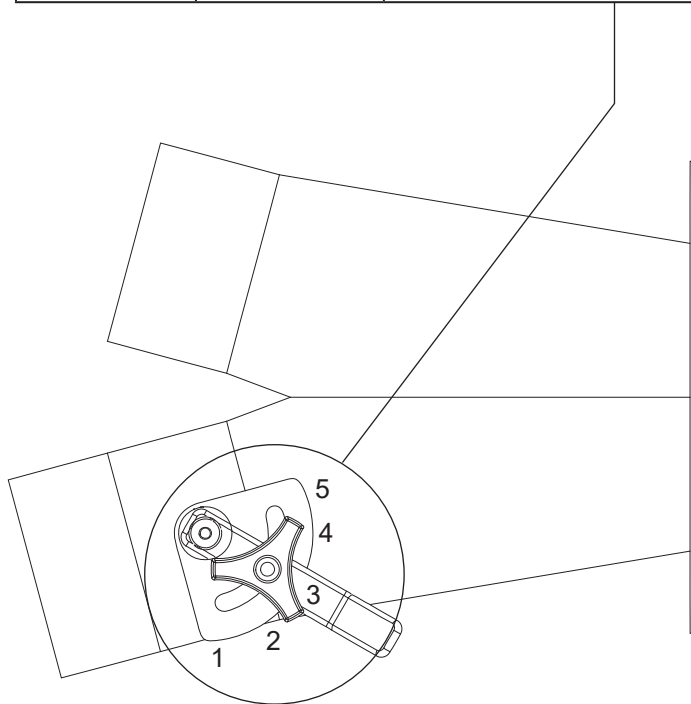

The Fan Speed shown on the Farmscan Jackal is for illustrative purposes only. Refer to the table for the correct setting.



# 'Renovator Classic Air' Operation

## Operation

### General Operation Guidelines

- 1 Hydraulic Fan -connect the hoses in the following order:

First - connect Zero pressure Case Drain 3/8" hose (1/2" BSP Female QR) to hydraulic reservoir \* Hose marked with short RED wrap.



Second -connect Motor Return 3/4" hose (3/4" BSP Female QR) to tractor high flow low pressure return port. Hose marked with medium length RED wrap.

Finally - connect High Pressure Motor feed 1/2" hose (1/2" BSP Male QR) to tractor remote. Hose marked with long RED wrap.  
Disconnect in the reverse order to prevent motor seal damage.

- \*The tractor hydraulic reservoir or free drain connection must have zero backpressure.



- 2 Use a sufficiently powerful tractor which is heavy enough to tow the drill safely.
- 3 Operate the drill at a speed of 6-12 km/hr (4-8 mph).  
In stony and uneven ground conditions a lower speed is more appropriate
- 4 Check that the drill is level during calibration and while seeding.
- 5 Check tyre pressure before seeding. Refer page 5.
- 6 Double check seed rates before seeding.
- 7 Raise the drill out of the ground when making any turns.
- 8 Raise the drill out of the ground before backing up.
- 9 After prolonged storage, check to see that all drive mechanisms and hydraulic equipment are functioning correctly. Check that the seed tubes are not perished or blocked.

### Sowing Speed

Typical travel speeds when sowing range from 6-12 km/hr in good conditions. In stoney and uneven ground conditions a lower speed is recommended to minimise rapid part deterioration. Sowing too fast can result in:

- 1 Poor contour following and uneven sowing depth.
- 2 Impact damage to:
  - a Ground engaging components.
  - b Bearings, housings & axles.
  - c Fasteners & structural components.
- 3 More extreme conditions will result in greater vibration and uneven seed flow at low seeding rates.

# 'Renovator Classic Air' General Operation

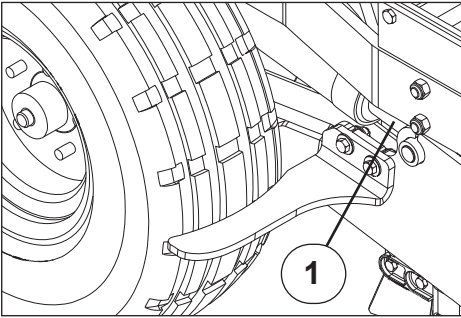

## Sowing Depth Control

The sowing depth is dependent on:

- 1 The wheel height in relation to the chassis
- 2 Tyre pressure
- 3 Ground condition i.e. hard or soft

The wheel height in relation to the chassis is controlled using the threaded depth adjustment collars on the wheel leg rams.

## Level Drill

Use the drawbar turnbuckle or ram to tilt the drill so it is sitting level. An adjustment may be required after a short period of use because the paint wears off the discs and the discs sharpen which in turn improves the penetration abilities. Ensure that the front and rear rows are at an even depth.

## Transport Position

When in the transport position the hydraulic cylinders are fully extended. In this position the cylinders fully equalise by allowing oil to bypass the master cylinder piston. It is recommended to raise the drill into the transport position when turning at headlands or regularly to counteract the effects of oil leakage past the piston and ensure cylinder rods are equally extended and minimise variations in sowing depth.

# 'Renovator Classic Air' Jackal Areameter

## Farmscan Jackal v3.5 Settings Setup

The unit supplied with the machine has already been setup at the factory to the settings shown below.

Refer to the manual supplied with your Farmscan Jackal kit for additional information and operation.

## Farmscan Jackal v3.5 Factory Setup for Renovator Classic Air

Refer to the Farmscan Jackal v3.5 manual.

**Input 1** - Three wire proximity sensor for 'Area/Speed Wheel' measurement taken from shaft on drive pedestal.

The white 'signal' lead is connected to input A1.

Input 1 Edit	
m/pulse	
Auto Set:	
Target:0.000m	
Meas.pulses:	0
Manual Ratio:	2.750000
<b>NEXT</b>	<b>EDIT</b>

Other Settings	
Implement Width:	2.802 m
Extern.Run/Hold:	Disabled
Alarm Beep:2	
<b>NEXT</b>	<b>EDIT</b>

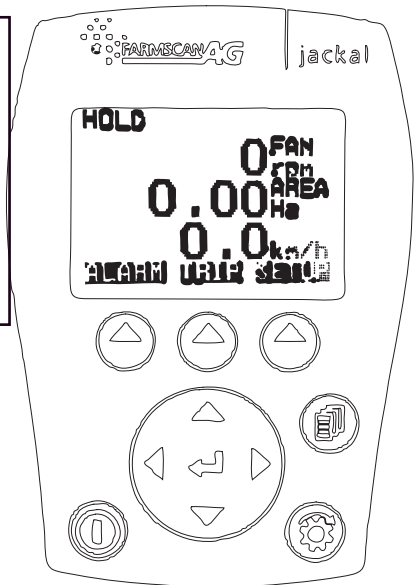

**Input 2** - Three wire proximity sensor for fan 'Tachometer' measurement. The white 'signal' lead is connected to input A2.

Input 2 Edit	
pulse/rev	
Auto Set:	
Target:0.000rev	
Meas.pulses:	0
Manual Ratio:	1.000000
<b>NEXT</b>	<b>EDIT</b>

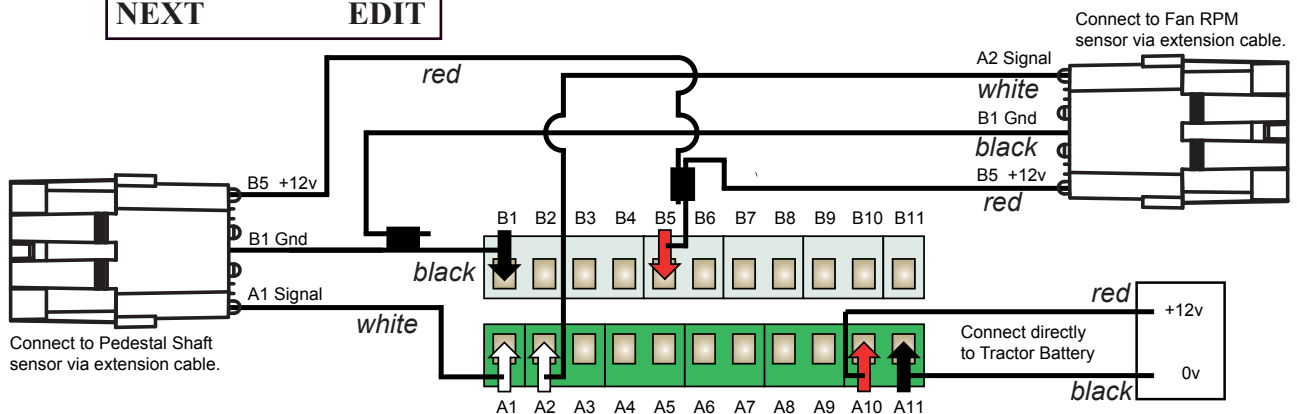

Refer to the Farmscan manual if you want to make additional sensor connections.

It is advisable, as with all things electronic, to have a backup of your totals. We suggest you record these on a daily basis in a notebook or diary.

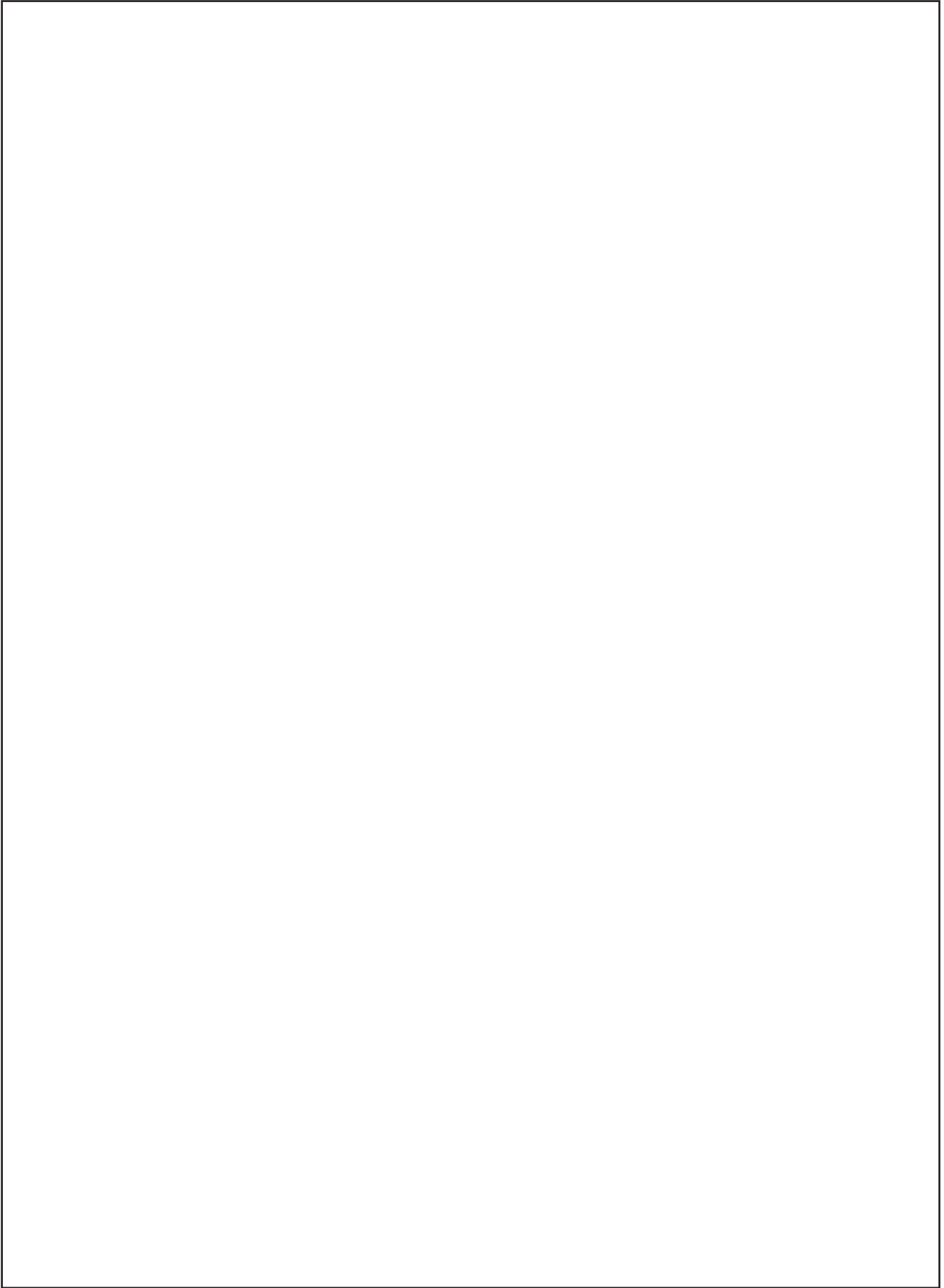



# 'Renovator Classic Air' Maintenance & Care

## Maintenance & Care

### General Safety and Accident Prevention Advice

- 1 Make sure that if the tractor remains attached to the drill that the ignition key is removed.
- 2 During maintenance the drill should be supported in such a manner that if hydraulic failure was to occur the machine would still be adequately supported.
- 3 Wear gloves when handling components with cutting edges such as worn discs etc.
- 4 Disconnect the electrical supply from the tractor before doing any electrical maintenance.
- 5 Refer to safety sections for more safety information.



### General Cautionary Maintenance Advice

- 1 **Electric Welding** - With the electronic equipment in modern tractors it is advisable to completely disconnect the implement from the tractor, or at the very least disconnect the alternator before attempting any welding.
- 2 **Hydraulics** - Ensure hydraulic couplings (male & female) are clean before connecting. Dirty couplings will result in hydraulic oil contamination and hydraulic cylinder seal/poppet valve damage and bore scores. This in turn will result in oil leakage past the piston seals.  
  
No filter is fitted to the hydraulic system. If hydraulic fittings and oil supply are not going to be kept clean it is recommended that a filter be fitted to prevent hydraulic cylinder damage.
- 3 **Water Blasting** - Water blasting, steam cleaning or other pressurised cleaning processes can force dirt etc. into undesirable places that may cause damage or rapid part wear to items such as bearings, seals, chains, bushes etc. Caution must be exercised.



# 'Renovator Classic Air' Maintenance & Care

## Maintenance & Care - Lubrication Instructions

### Precautions with Grease

Greases should not be mixed as the structure may be weakened by the mixes of different types of thickener, which may cause softening and loss of grease from the bearings by running out.



Your new Duncan Renovator Classic Air will give long and efficient service if given normal care and maintained properly.

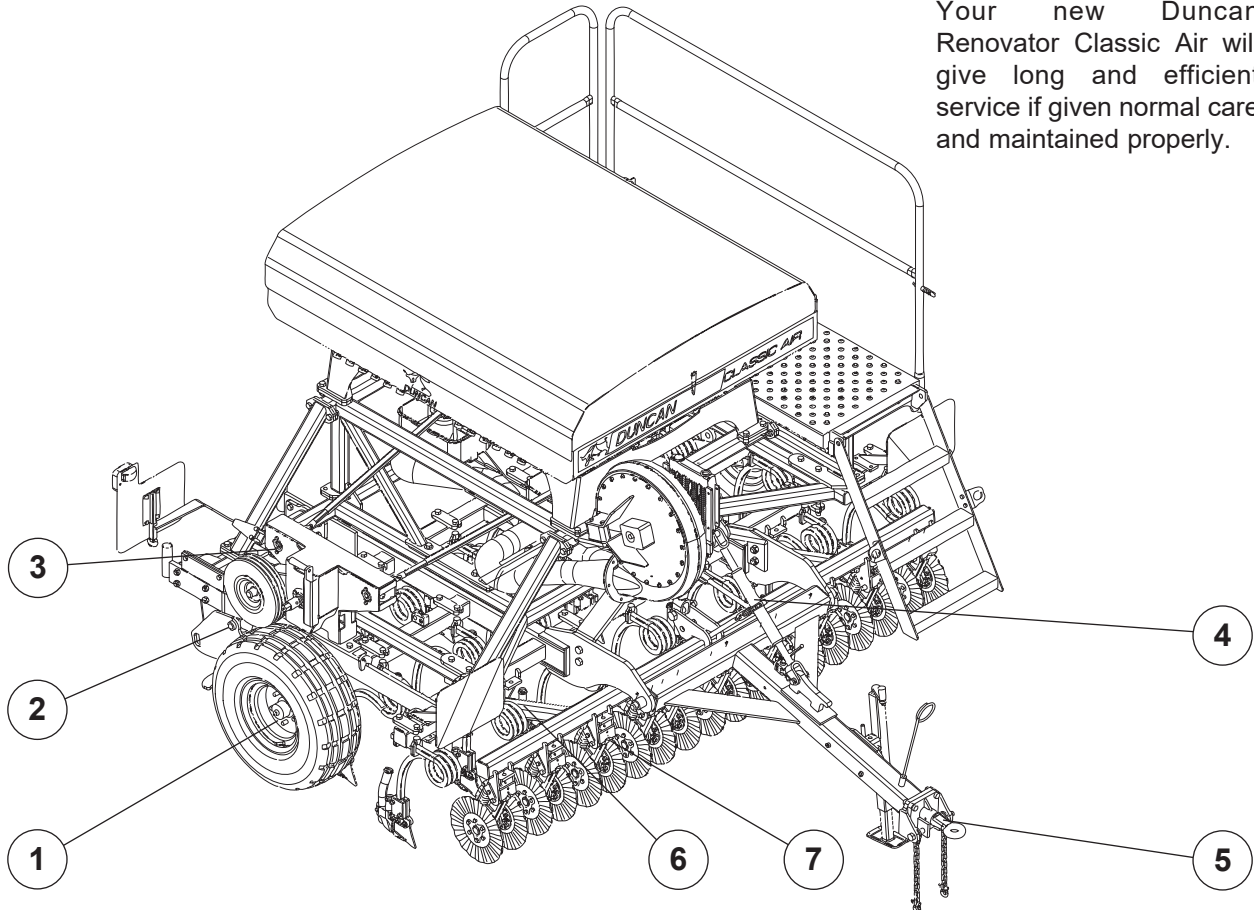

### Lubrication Chart

Item	Components	Lubricant	Frequency
1	Wheel Bearings	Castrol LMX Grease	Annually
2	Wheel Leg Pivots	Castrol LMX Grease	Weekly
3	Drive Chains	Suitable Roller Chain Lubricant	See Maintenance Schedule
4	Turnbuckle	Castrol LMX Grease	Monthly
5	Coupling	Castrol LMX Grease	Weekly
6	Disc Arm Castings	Castrol LMX Grease	Daily
7	Disc Opener Fr. Pivots	Castrol LMX Grease	Monthly

\* The lubrication frequencies are only a guide. Actual frequency will be dependent on extent of use and ground conditions.

# 'Renovator Classic Air' Maintenance & Care

## Maintenance & Care - Lubrication Instructions

Components	Daily (or after 20Ha)	Weekly (or after 75Ha)	Pre Season (or 500 Ha)
Disc Openers (if fitted)	•	•	•
Depth Adjustment Collar	•	•	•
Wheel Nuts	•	•	•
Pivot Pin Fasteners		•	•
Coupling & Safety Chains		•	•
Roller Chains		•	•
Hydraulics (Oil Leaks)		•	•
Tyre Pressures		•	•
Bolted Connections			•

### Maintenance Schedule

(Refer also to Summary Chart, above)

#### 1. Bolted Connections

All bolted connections of the machine should be checked after the first 3 to 5 hours of operation and retightened if necessary and thereafter at regular intervals. It is suggested that this is done every 500 hectares or annually, whichever occurs first.

#### 2. Drive Chains

All drive chains should first be checked after every 20 hours of operation and thereafter weekly or after 75Ha of operation as follows:-

The metering units of the seed drill are driven via driveshafts and roller chains from the drive wheel. Cleaning of the roller chains is recommended after long periods of operation. Remove the chain, wash in kerosene and then dip them in heated grease or oil or spray them with a suitable commercial roller chain lubricant. Do not heat the black plastic chain tensioners; just wash in kerosene and refit. The lubricant on the chain will transfer to the tensioner in use.

#### 4. Wheel Arm Pivots

Wheel arm pivots must be greased regularly (weekly or after every 75Ha) to provide lubrication and flush out any dirt. (1).

#### 5. Depth Adjustment Collar

Grease the depth adjustment collar (2) regularly to ensure it does not seize up. Also check for dirt buildup around the ram shaft seals to ensure seal damage does not occur.

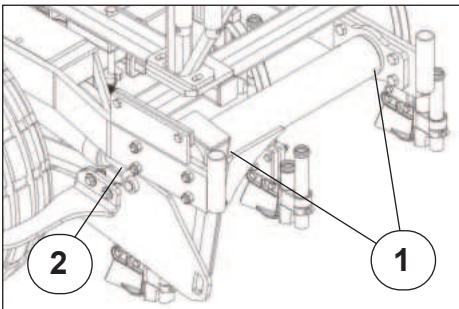



# 'Renovator Classic Air' Maintenance & Care

## Maintenance Schedule (continued)

### 6. Tyre Pressure

The recommended tyre pressure is listed on Page 5. Weekly checks are recommended.

### 7. Disc Openers

Front coulter bearings are sealed and do not require lubrication. Check discs for any lateral movement (wobble) on a regular basis. Replace bearings if there any noticeable wobble.

There is one grease nipple on each disc opener frame pivot and disc assembly casting. Frame pivots should be greased monthly while disc castings should be greased daily to provide lubrication and to flush out any dirt.

### 8. Framework

The framework structure should be inspected annually for defects, i.e., cracks in members or welded connections. The framework should be cleaned prior to the inspection.

### 9. Metering Units

Ensure that the metering units are clean and that the rubber sealing lip is not damaged. The sealing lip is located along the base of the trap door hinge. A damaged sealing lip can cause seed delivery problems.

### 10. Fan Hydraulic Motor

Hydraulic Fan -connect the hoses in the following order:

First - connect Zero pressure Case Drain 3/8" hose (1/2" BSP Female QR) to hydraulic reservoir \*  
Hose marked with short RED wrap.

Second -connect Motor Return 3/4" hose (3/4" BSP Female QR) to tractor high flow low pressure return port.  
Hose marked with medium length RED wrap.

Finally - connect High Pressure Motor Feed 1/2" hose (1/2" BSP Male QR) to tractor remote.  
Hose marked with long RED wrap.

Disconnect in the reverse order to prevent motor seal damage.

\*The tractor hydraulic reservoir or free drain connection must have zero backpressure.

# 'Renovator Classic Air' Maintenance & Care

## Maintenance & Care (Continued)

### **Preparing the Machine for Storage.**

Locate on a dry level surface. The machine should be stored wherever possible so the rams are not supporting any weight. The drive chains should be lubricated with suitable roller chain lubricant before prolonged periods of storage.

It is recommended that maintenance be carried out at the end of the season, giving sufficient time to obtain spare parts and/or carry out repairs if required.

The seed and fertilizer bins must be completely emptied and cleaned

Leave the metering unit trap doors open.

Fit the cover to the bin.

# ‘Renovator Classic Air’ Troubleshooting

<b>Problem</b>	<b>Possible Cause</b>	<b>Action</b>	<b>Refer to Page...</b>
Over Sowing	Jockey wheel under inflated	<i>Check pressure</i>	5
	Are the Jackal meter settings correct?	<i>Check settings</i>	25
	Has the setup/calibration procedure been followed correctly?	<i>Check setup and recalibrate</i>	20
	Gearwheel position incorrect	<i>Check setup for seed type</i>	20
	Crank handle turned too quickly when calibrating	<i>Only 1.5 seconds per revolution</i>	21
Under Sowing	Has the setup/calibration procedure been followed correctly?	<i>Check setup and recalibrate</i>	20
	Gearwheel position incorrect	<i>Check setup for seed type</i>	20
	Are the calibration scales in kg (not lbs)?	<i>Check scales</i>	-
	Sowing at shallow depths. Is there sufficient pressure on the jockey wheel?	<i>Check and adjust spring pressure</i>	-
	Metering unit is clogged	<i>Clean metering unit</i>	-
Cracking noises coming from the metering unit	Very large seed	<i>Remove roll pins from agitator shaft</i>	
Drill sowing deeper on one side/leaking down on one side	Hydraulic lift rams have not rephased properly	<i>Rephase rams</i>	36
	Dirt in the poppet valve of the ram	<i>Clean/replace valve</i>	
Tines are moving	Too much turning with drill in the ground	<i>Keep turning to minimum</i>	-
Drill not penetrating into ground/drill riding out of ground	Operating the drill in the float position	<i>Do not operate in float</i>	-
	Disc openers are keeping the drill from penetrating into the ground	<i>Lift discs out of the ground</i>	-

# 'Renovator Classic Air' Phasing Cylinders

## Commisioning Phasing Cylinders

### 1. General

(a) The cylinders will re-phase in both directions. Each piston is fitted with 2 poppet valves which open at the end of the stroke to allow oil to bypass the piston. The bypass of oil at the end of the stroke allows for initial bleeding of the system and re-phasing in operation.

(b) The valve in the piston is a precision device, **CLEANLINESS IS OF THE UTMOST IMPORTANCE.** Contamination in the oil will accelerate deterioration of the valve seat. Cylinders will creep once the integrity of the seating is lost.

### 2. Bleeding the System

#### (a) Initial bleeding after connection to the tractor

Purge all air from the system by fully stroking rams in both directions. Allow the oil to flow through the cylinders with the tractor at an idle for a minimum of 2 minutes at each end of the stroke.

#### (b) Re-phasing after initial bleeding

After initial bleeding the cylinders will only require occasional re-phasing during operation. This is done by extending the rams for about 30 seconds or until all cylinders have reached the end of their stroke.

### 3. Fault Finding

#### 1. Cylinders creeping during operation

There are two primary causes of this:

- (i) Air in the hydraulic system
- (ii) By passing of the poppet valve.

(a) Check that there is no air in the system. Raise and lower the machine. All cylinders should move instantaneously, any lag indicates that there is air in the system. Other signs of air in the system are hoses vibrating/squealing or the control handle shuddering. Re-bleed the system if necessary.

(b) If there is no sign of air in the system and the cylinders still creep, raise the machine off the depth stop and measure the movement of each cylinder rod.

(c) If both cylinders move at the same rate it is likely to be the control valve/lock out valve that is leaking.

(d) If the slave continues moving after the master cylinder has hit the depth stop it is likely to be the piston in the master cylinder that is bypassing.

(e) If the slave cylinder extends while the master cylinder retracts it is likely to be the piston in the master cylinder that is bypassing.

(f) If the master cylinder does not move but the slave does it is likely to be the piston in the slave cylinder that is bypassing.

(g) If the piston is bypassing it is likely to be contamination in the phasing valve. The cylinder will have to be dismantled, cleaned and fitted with a new poppet valve.

# 'Renovator Classic Air' Phasing Cylinders

## Commisioning Phasing Cylinders (continued)

### 3. Fault Finding (continued)

#### 2. Cylinders moving at different rates

(a) Check that there is no air in the system. Raise and lower the machine; all cylinders should move at the same time, any lag indicates that there is air in the system. Re-bleed the system if necessary.

(b) Ensure that the cylinders have been connected correctly. The cylinders should be connected in series so that the bore sizes go down in 1/4" increments. The Rod end port of the master cylinder (3.5" bore) is connected to the piston end port of the slave cylinder (3.25" bore).



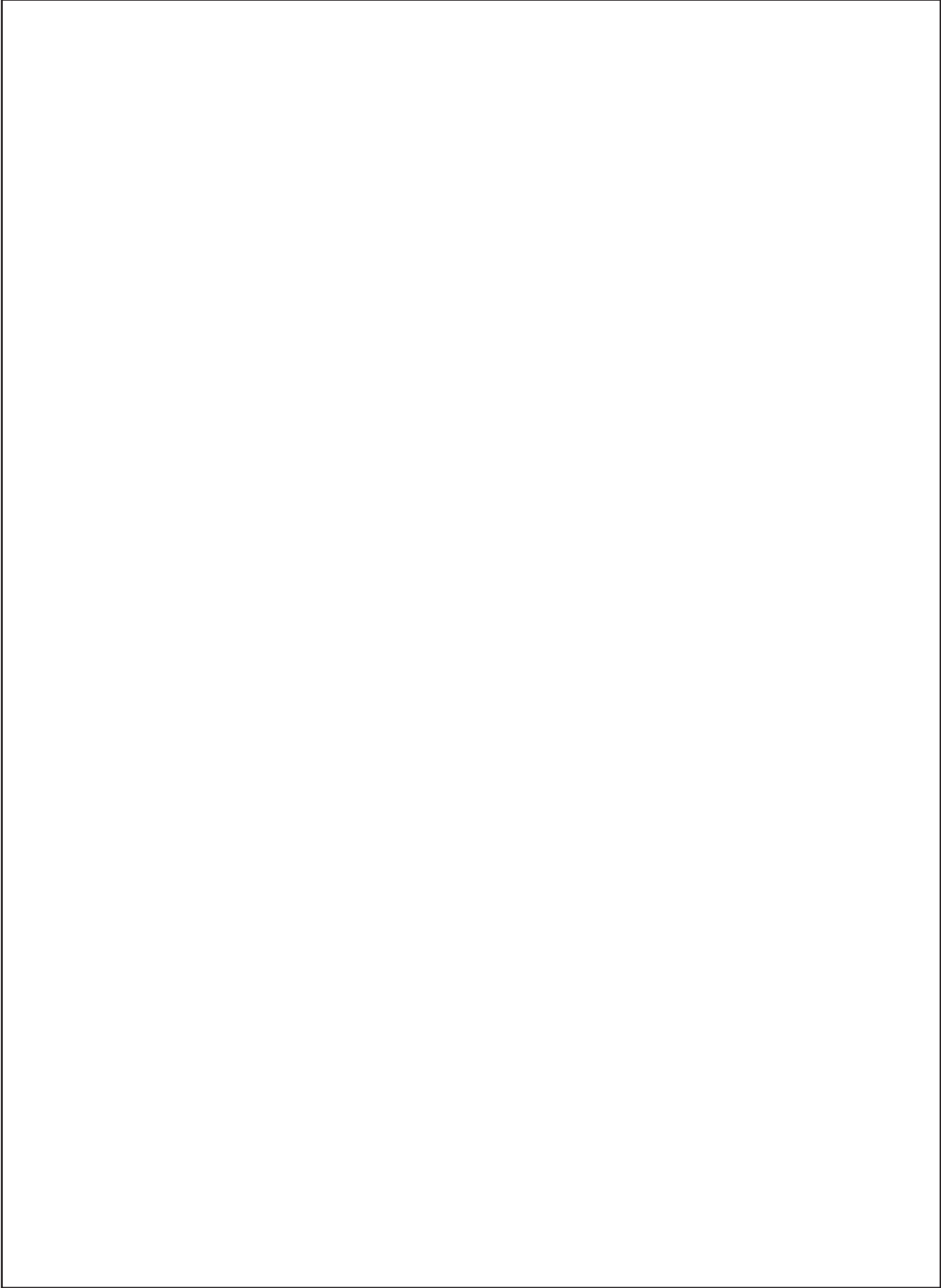

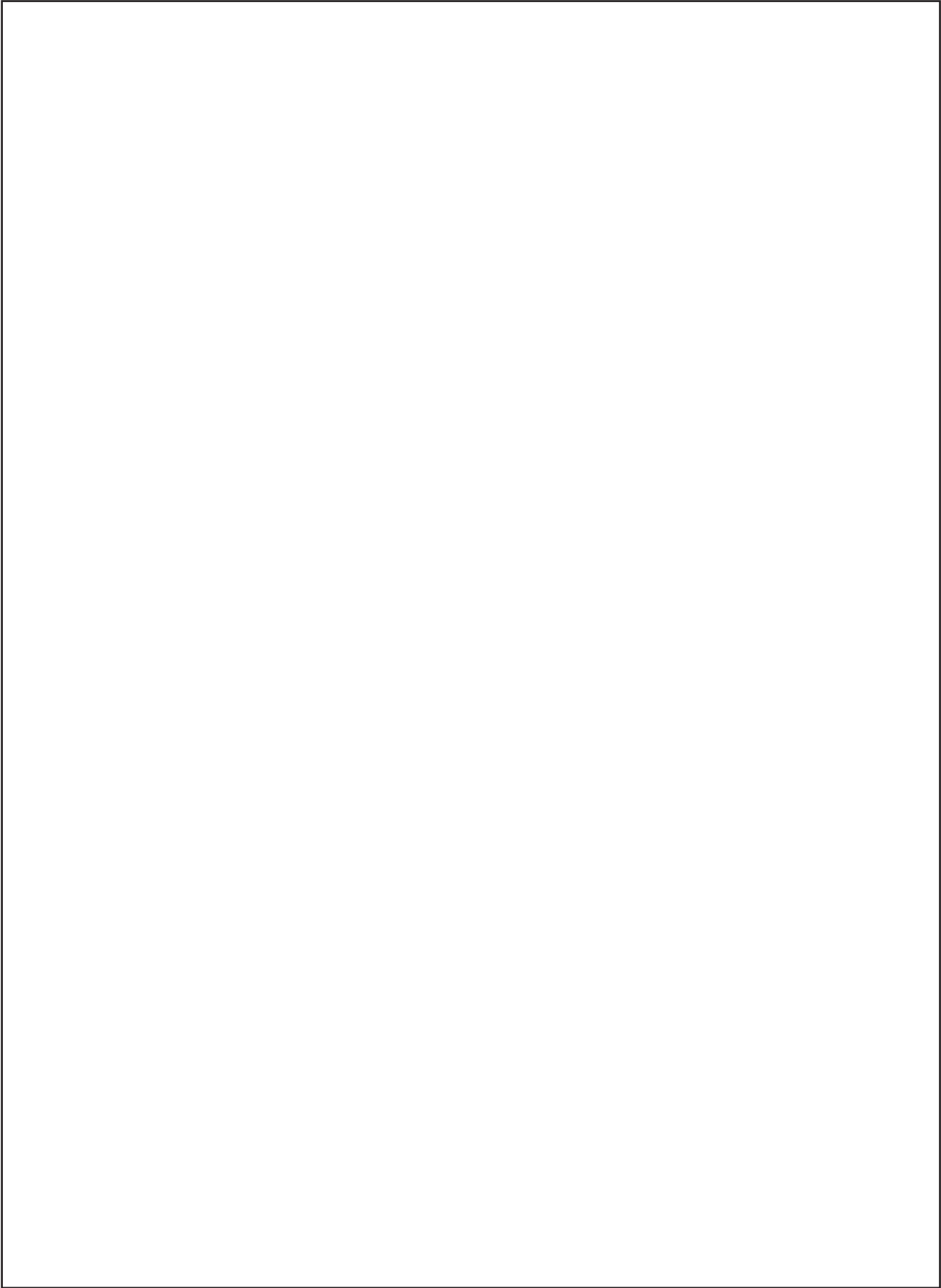



# Parts List



## 'Renovator Classic Air' Seed Drill

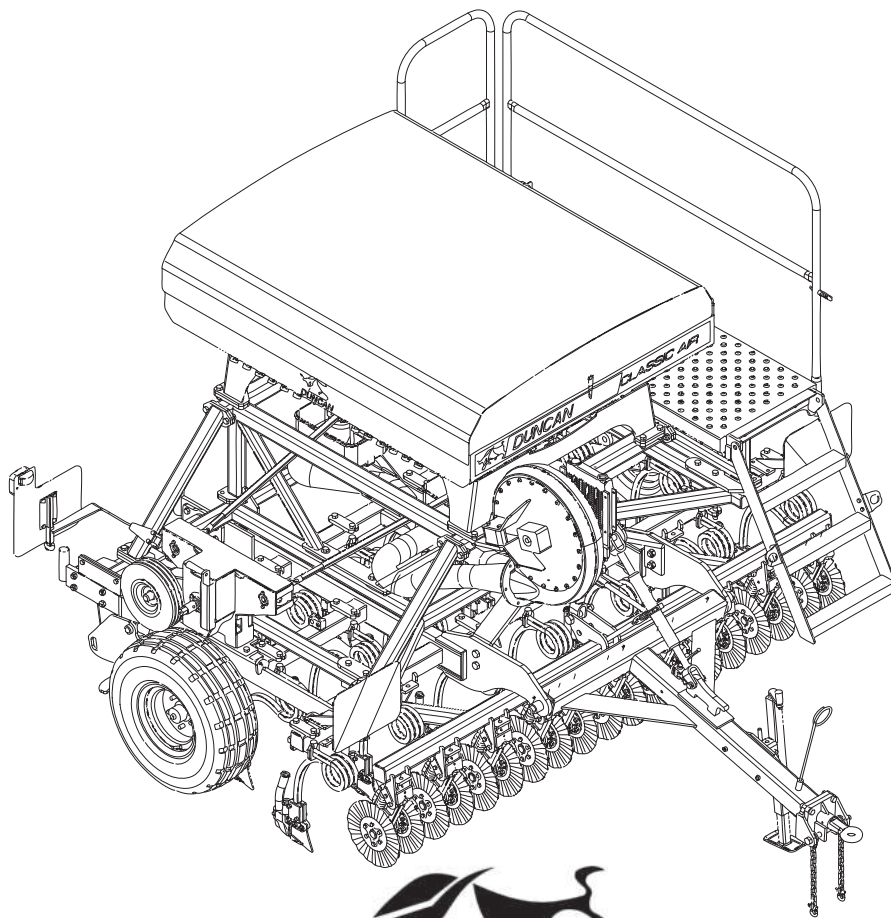

*Built to work.*

**Timaru Branch:**  
100 Hilton Highway, Washdyke,  
Timaru, New Zealand  
Tel: +64 3 688 2029  
Email: [timadmin@giltrapag.co.nz](mailto:timadmin@giltrapag.co.nz)  
Web: [www.giltrapag.co.nz](http://www.giltrapag.co.nz)

**Australian Branch:**  
105-117 Boundary Road,  
Laverton North, Melbourne,  
VIC 3026, Australia  
Tel: +61 3 9369 6548  
Email: [admin@giltrapag.com.au](mailto:admin@giltrapag.com.au)  
Web: [www.giltrapag.com.au](http://www.giltrapag.com.au)

**Pt. No. 67398**  
**Rev 0824**

# 'Renovator Classic Air' Complete Assembly

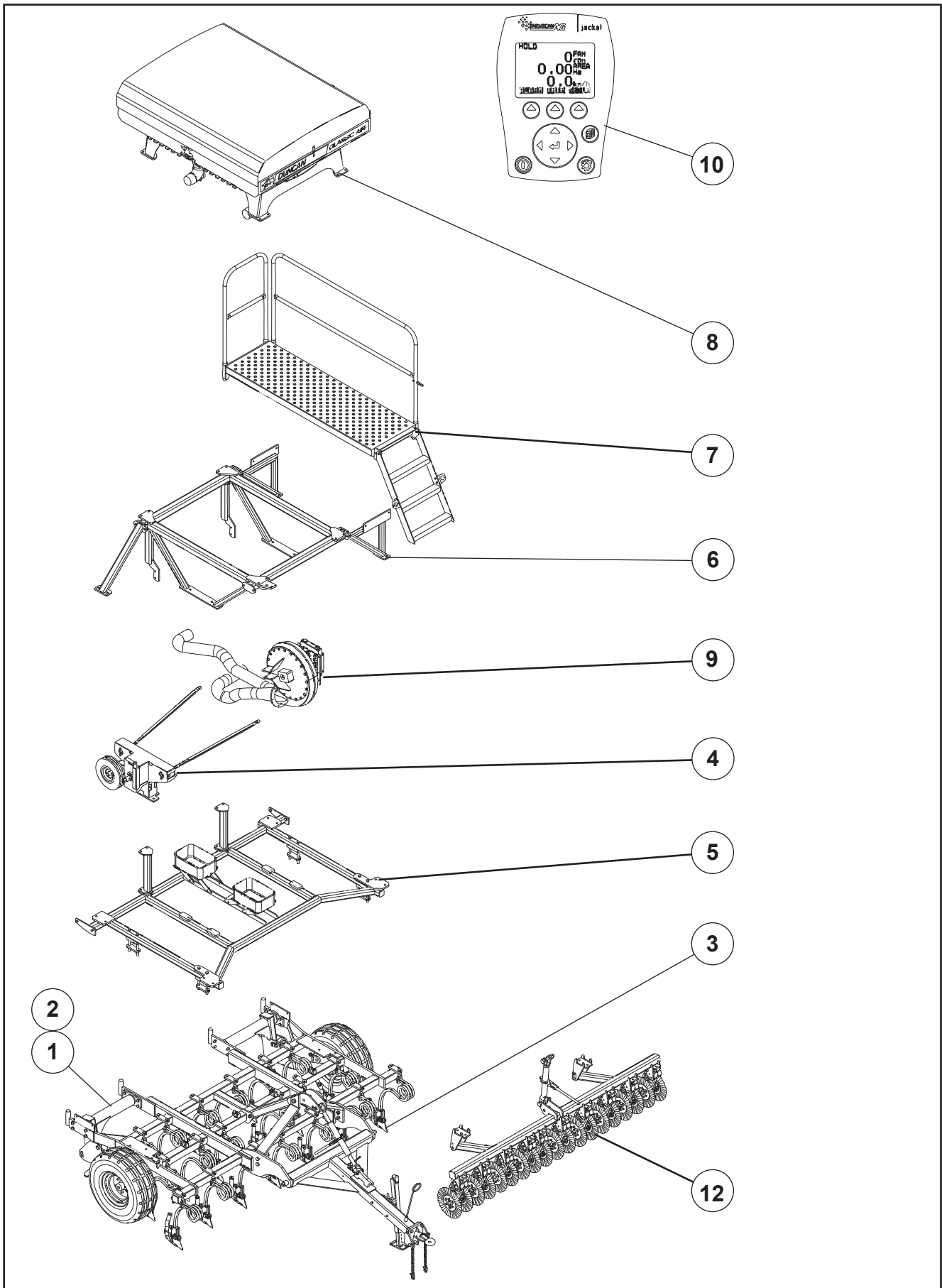

# ‘Renovator Classic Air’ Complete Assembly

ITEM	PART No.	DESCRIPTION	QTY
1	Refer Page 42	Main Frame & Drawbar Assembly	-
2	Refer Page 46	Wheel Leg	2
3	Refer Page 50	Tine Assemblies	-
4	Refer Page 52	Seed Metering Drive Pedestal	1
5	Refer Page 58	Adapter Frame	1
6	Refer Page 60	Box Mounting Frame	1
7	Refer Page 62	Footboard & Ladder	1
8	Refer Page 64	Seed Box & Metering Units	1
9	Refer Page 68	Fan & Air Hoses	1
10	Refer Page 71	Farmscan Jackal	1
11	Refer Page 74	Lighting Kit (Optional)	-
12	Refer Page 76	Disc Openers (Optional)	-
13	Refer Page 80	Row Markers (Optional)	-



# 'Renovator Classic Air' Mainframe & Drawbar

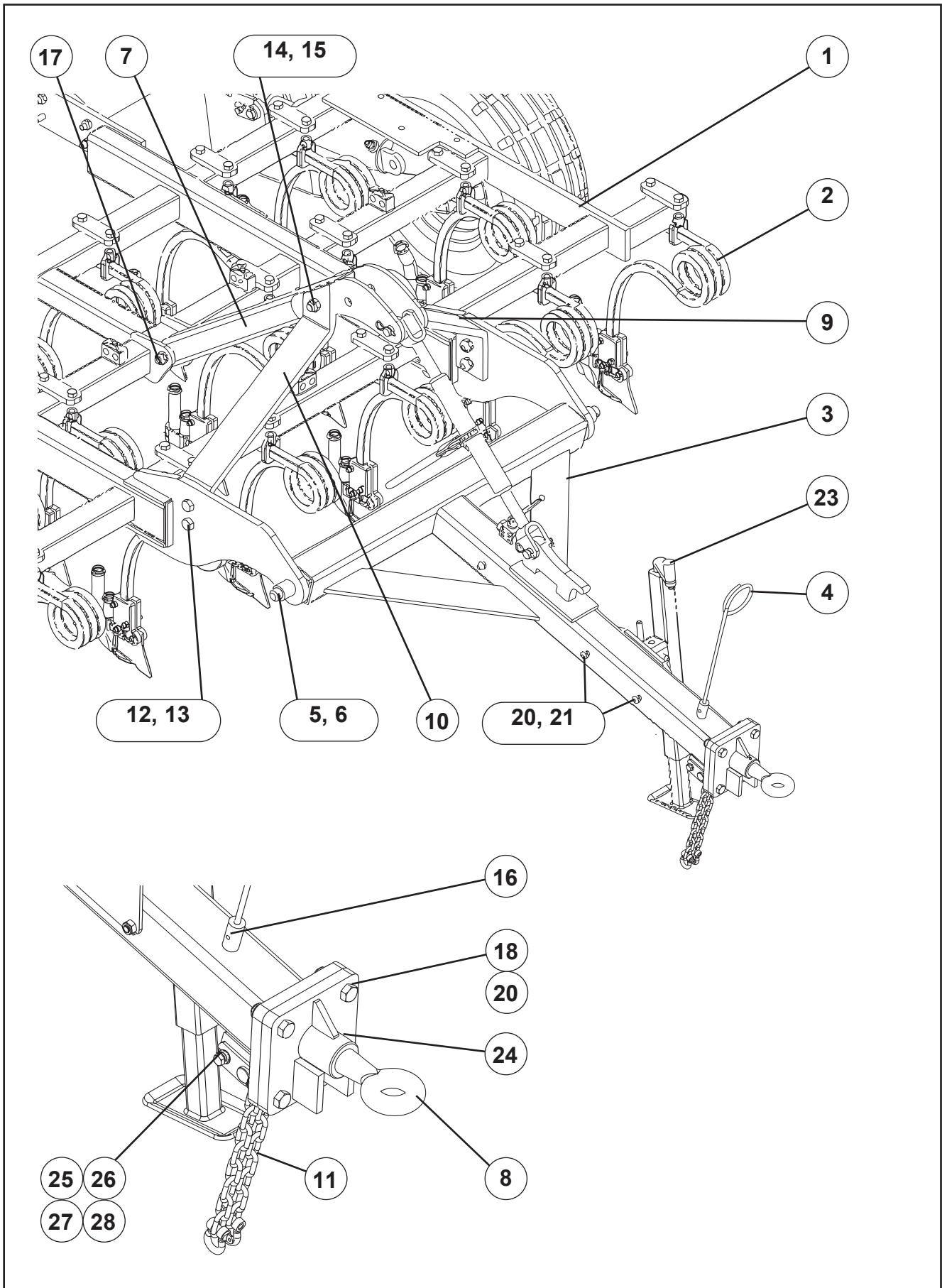

# 'Renovator Classic Air' Mainframe & Drawbar

ITEM	PART No.	DESCRIPTION	QTY
1	26512	19R Mainframe	1
2	Refer page 50	Coil Tines & Boots	-
3	26550	Drawbar Assembly	1
4	4800315	Hose Support	1
5	60094	Drawbar Axle	1
6	45285	Roll Pin Ø10	2
7	60192	Centre Hitch Welded Assembly	1
8	26580	Towing Eye Assembly	1
9	26577	LH Support Stay	1
10	26578	RH Support Stay	1
11	43830	Safety Chain Assembly	2
12	45066	M20 x 70 Grade 8.8 Bolt	4
13	45141	M20 Nyloc Nut	6
14	47244	7/8" UNF Bolt x 6.5"	1
15	47548	7/8" UNF Nut	1
16	45181	M8 x 12 S/H Grub Screw	1
17	45075	M20 x 150 Grade 8.8 Bolt	1
18	45042	M16 x 60 Grade 8.8 Bolt	4
19	45140	M16 Nyloc Nut	4
20	45033	M12 x 120 Grade 8.8 Bolt	2
21	45139	M12 Nyloc Nut	3
23	-	Jack Stand Kit – Optional	1
24	43007	Grease Nipple	1
25	22262	Clevis Pin Tabbed	1
26	45001s	M10 x 20 S/Screw Grade 8.8 Z/P	1
27	45152	M10 Light Flat Washer	1
28	45166	M10 Spring Washer	1

# 'Renovator Classic Air' Mainframe and Drawbar

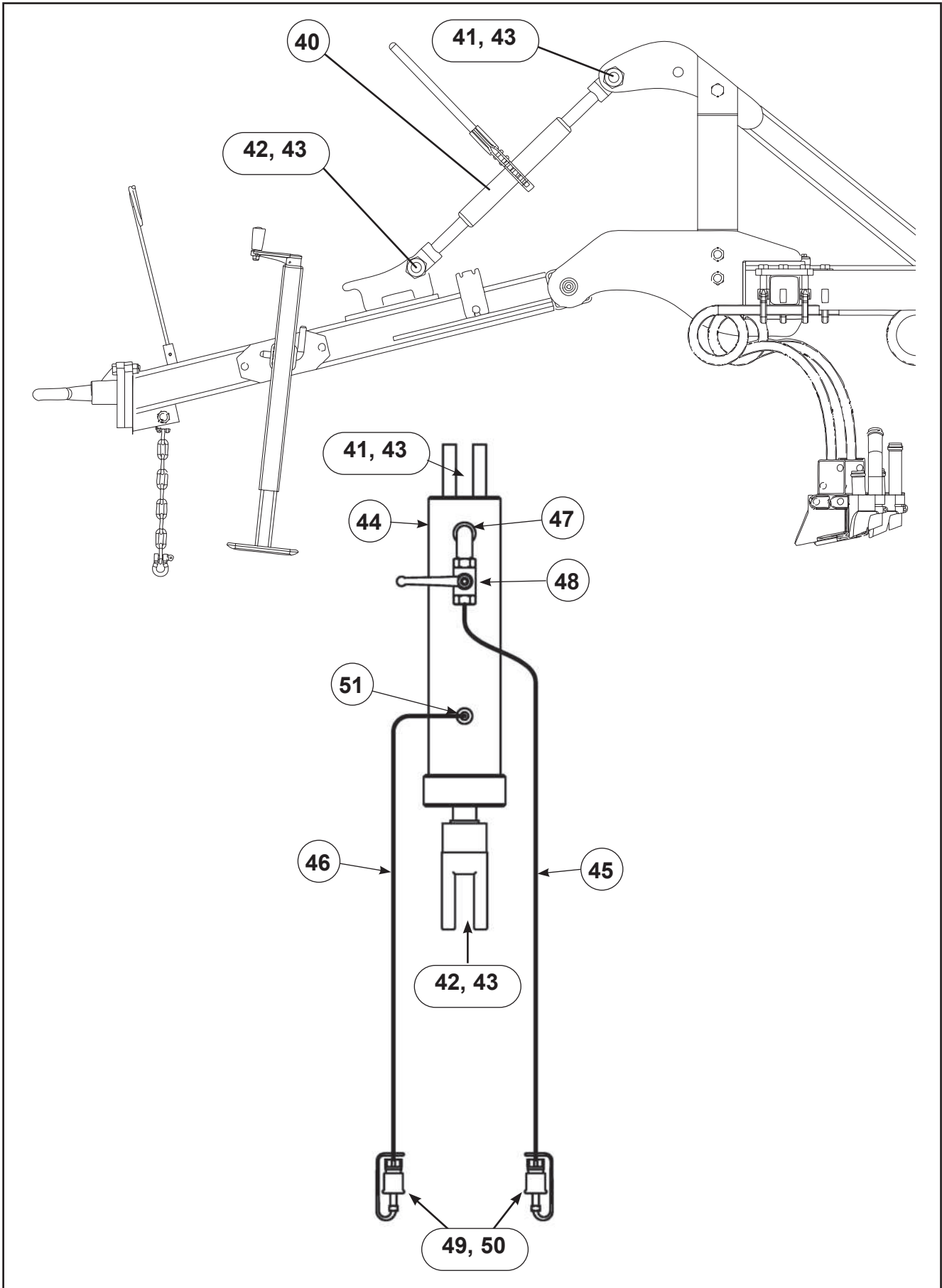

# 'Renovator Classic Air' Mainframe and Drawbar

ITEM	PART No.	DESCRIPTION	QTY
40	43395	H/D Ratchet Turnbuckle	1
41	47254	Bolt 1" UNF x 5" HT	1
42	47251	Bolt 1" UNF x 3.5" HT	1
43	47552	1" UNF Nyloc Nut	2
44	43852	Hydraulic Cylinder	1
45	26723	Hydraulic Hose 2.80m	1
46	26724	Hydraulic Hose 2.50m	1
47	43496	3/4" UNO to 3/8"BSPT Elbow	1
48	43393	3/8" BSP S/S Ball Valve	1
49	43147	1/2" BSP Quick Release Coupling	2
50	43617	Dust Cover	2
51	43280	3/4" UNO to 3/8" BSPM Nipple	1

*Note: Drawbar hydraulic parts (41-51) can be purchased as a kit, part number 26720K.*

# 'Renovator Classic Air' Wheel Rocker System

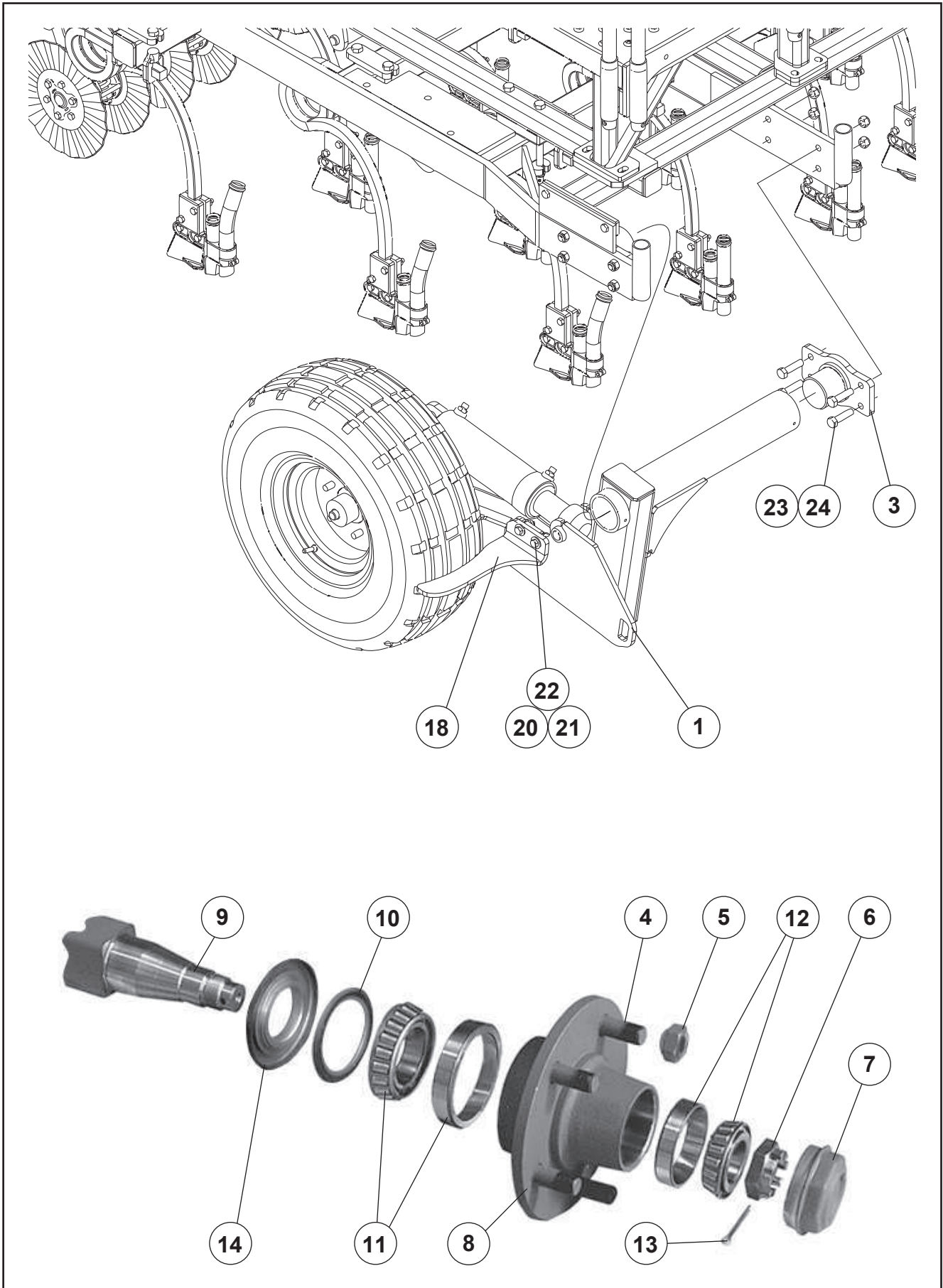



# 'Renovator Classic Air' Wheel Rocker System

ITEM	PART No.	DESCRIPTION	QTY
1	62013	LH Wheel Rocker Welded Assy	1
2	62014	RH Wheel Rocker Welded Assy (not shown)	1
3	26585	Rocker Pivot Assy	4
4	43596	ADR M16-1.5P x45 Hub Stud	10
5	43597	ADR M16-1.5P Wheel Nut	10
6	43598	ADR M27-1.5P Castle Nut	2
7	43599	ADR 62mm Hub Cap	2
8	43600	ADR Hub MkII	2
9	26620	ADR MkII Stub Axle (Welded to Wheel Rockers)	2
10	43976	Seal Kit	2
11	43421	30209 J2 Inner Bearing	2
12	10282	30206 J2 Outer Bearing	2
13	45303	3.5 Diameter x 40 Long Cotter Pin	2
14		Trash Shield (part of item 10)	2
15	43836	Mk 2 ADR Hub and Stub Assembly Complete (Items 4-14)	2
16	43833	Wheel 10/80-12	2
17	26592	Rocker Shaft Plug (Not Shown)	4
18	62028	LH Wheel Scraper Assy	1
19	62029	RH Wheel Scraper Assy (not shown)	1
20	45437	M12x 50 Bolt	4
21	45139	M12 Nyloc Nut	4
22	45153	M12 Light Flat Washer	4
23	45042	M16 x 60Grade 8.8 Bolt	16
24	45140	M16 Nyloc Nut	16
25	43120	M8 x 1.25 Pitch Grease Nipple x 90 degree (Not Shown)	4

# 'Renovator Classic Air' Wheel Rocker Hydraulics

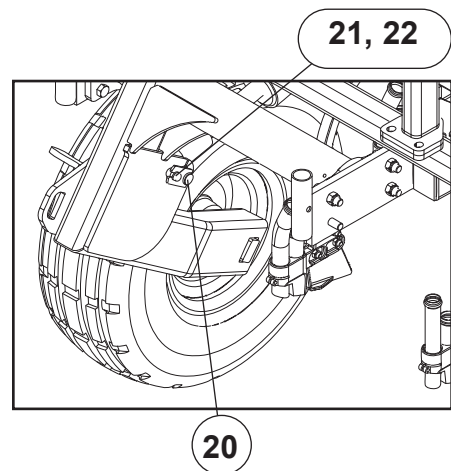
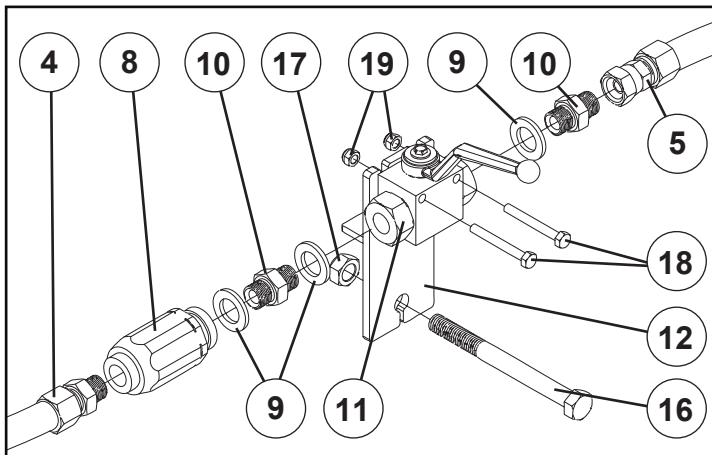
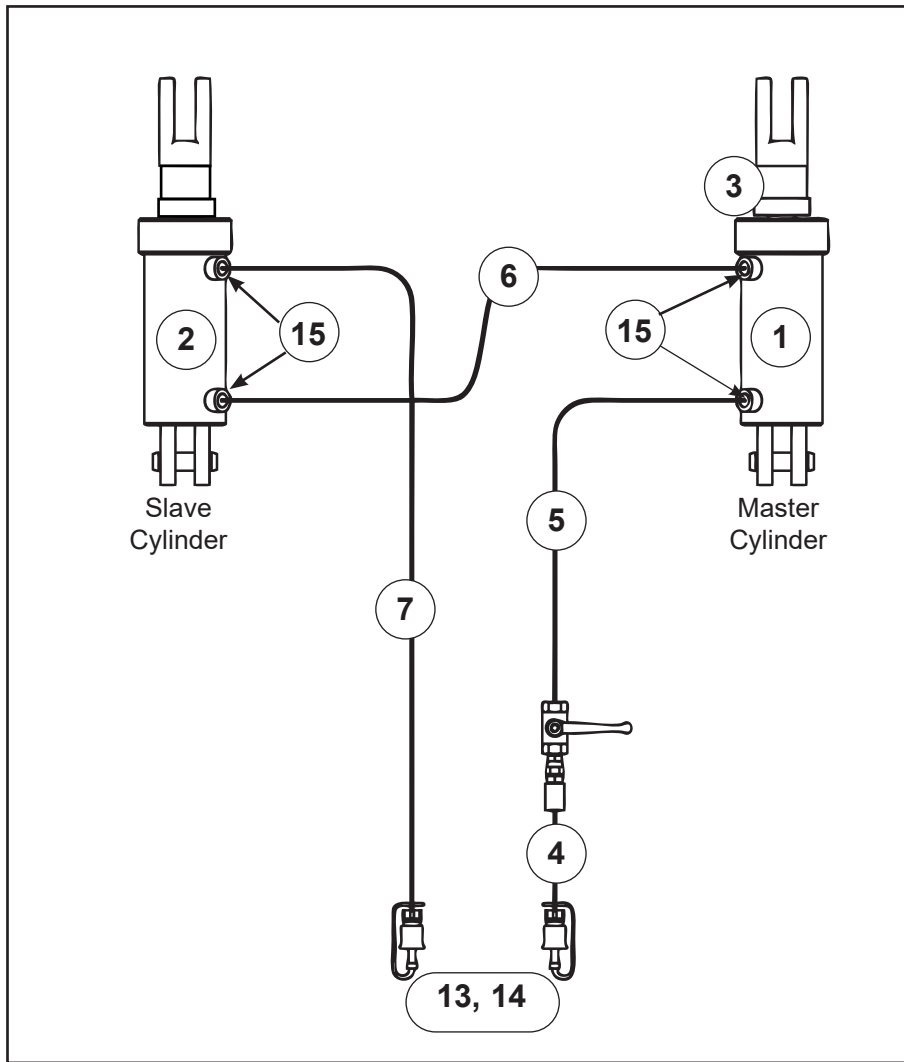

# 'Renovator Classic Air' Wheel Rocker Hydraulics

ITEM	PART No.	DESCRIPTION	QTY
1	26702	3.5" x 6.5" Master Rephasing Cylinder (Includes pin)	1
2	26703	3.25" x 6.5" Slave Rephasing Cylinder (Includes pin)	1
3	43848	Stroke Limiting Collar 7/8" (where fitted)	1
4	60866	Hydraulic Hose, 2.70m	1
5	26713	Hydraulic Hose, 2.33m	1
6	26714	Hydraulic Hose, 2.80m	1
7	26715	Hydraulic Hose, 5.30m	1
8	43028	3/8" Flow Control	1
9	43391	3/8" Dowty Washer	3
10	43392	3/8" BSPP Male Nipple	2
11	43393	3/8" BSP S/S Ball Valve	1
12	60856	Hydraulic Valve Support Assy	1
13	43147	1/2" BSP Quick Release Coupling	2
14	43617	Dust Cover	2
15	43280	3/4" UNO to 3/8" BSP Nipple	4
16	45033	M12 x 120 Bolt	1
17	45139	M12 Nyloc Nut	1
18	44957	M6 X 50 Bolt	2
19	45136	M6 Nyloc Nut	2
20	22262	Clevis Pin Assembly	2
21	45418s	M10 x 25 Set Screw	2
22	45166	M10 Spring Washer	2

# 'Renovator Classic Air' Tine & Boot Assembly

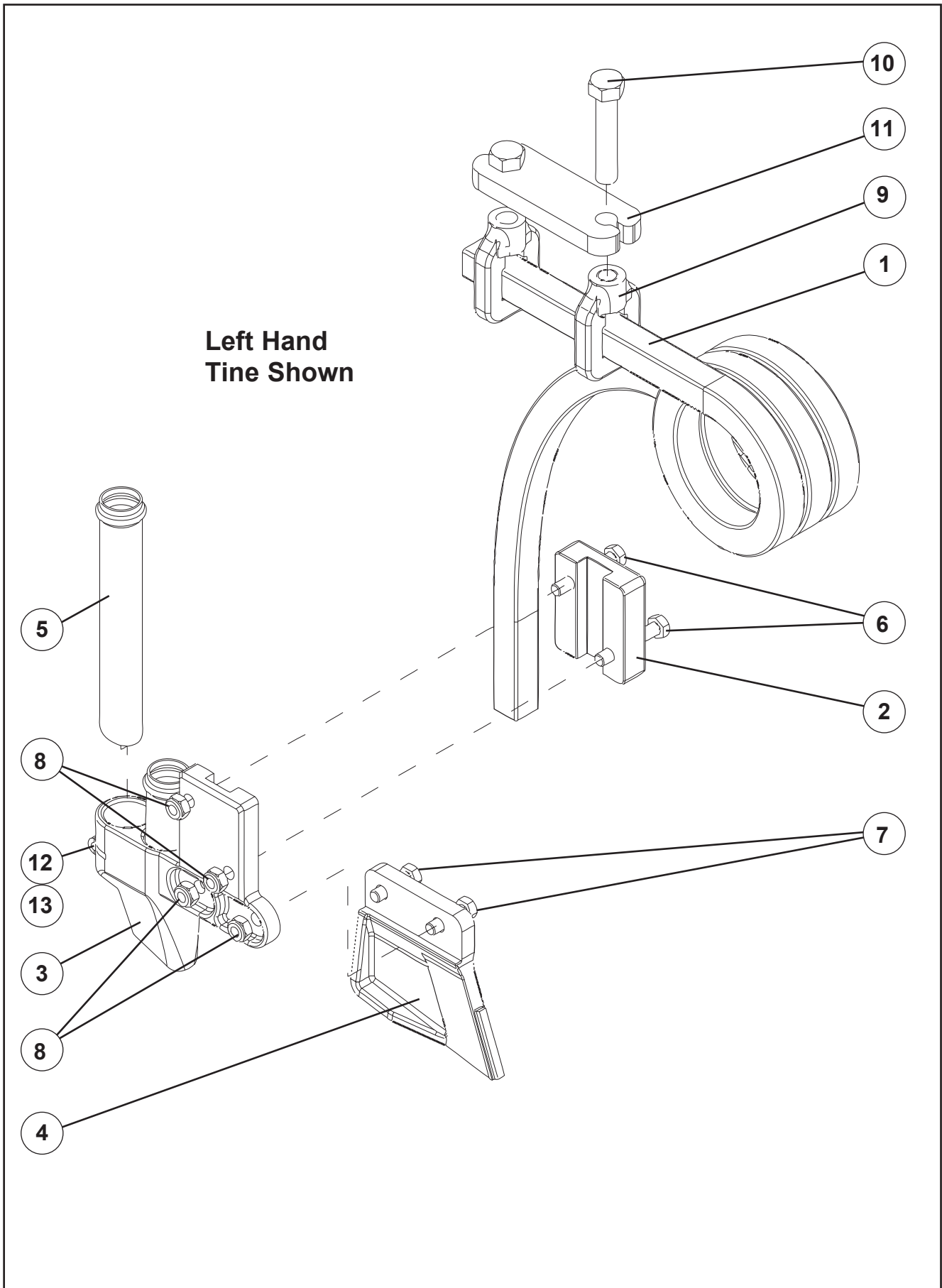

# 'Renovator Classic Air' Tine & Boot Assembly

ITEM	PART No.	DESCRIPTION	QTY
1	21413	LH Coil Tine	10
1	21414	RH Coil Tine	9
2	26848	LH Inverted Tee Clamp	19
3	25615	RH Inverted Tee Clamp	19
4	26849	Cast Inverted Tee Point	19
5	25608	Fertilizer Tube, Standard (dual box)	19
6	45010	M10 x 65 Bolt, Class 8.8	38
7	45003	M10 x 30 Bolt, Class 8.8	38
8	45138	M10 Nyloc Nut	76
9	21691	Tine Clamp Casting	38
10	45466	M16 x 80 (4.6) Zinc Plated Bolt	38
11	21690	75 x 75 RHS Clamp Plate	19
12	45413	M8 x 35 Bolt (dual box)	19
13	45137	M8 Nyloc Nut (dual box)	19
14	43691	Feed Hose 38mm	per mtr
15	43500	Cray Clip 47-49mm (fitted to top of hose not shown)	19

# 'Renovator Classic Air' Jockey Drive

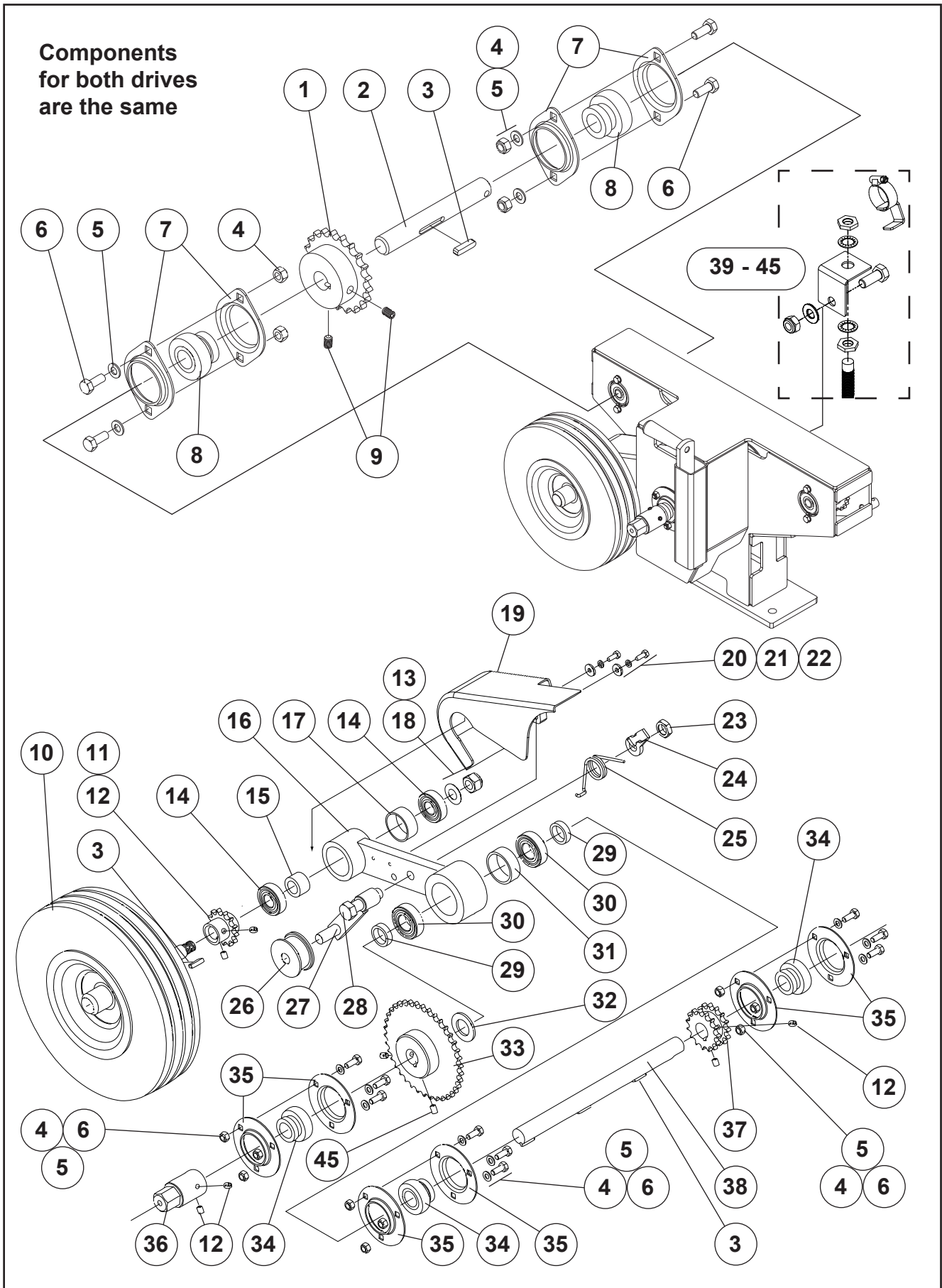

# 'Renovator Classic Air' Jockey Drive

ITEM	PART No.	DESCRIPTION	QTY
1	63128	21T Sprocket 1/2"P 20mm Bore	2
2	25758	Box Drive Shaft	2
3	22294	Sprocket Key (6 x 6 x 25)	6
4	45137	M8 Nyloc Nut	17
5	45151	M8 Light Flat Washer Z/P	17
6	44992s	M8 x 20 Grade 8.8 Z/P S/Screw ...	17
7	43387	Bearing Housing PF47 (1 housing = 2 flanges)	4
8	43385	Bearing YET204 20mm	4
9	45181	M8 x 12 Socket/HD Grub Screw (knurled point)	6
10	25744	Jockey Wheel and Axle W/Assy	1
11	25724	13T Sprocket 1/2"x 20mm Bore	1
12	45180	M8 x 10 Socket/HD Grub Screw (knurled point)	6
13	47625	M16 Bellville Washer S/S304	1
14	17127	Bearing 6204	2
15	25739	Jockey Axle Inner Spacer	1
16	25735	Jockey Wheel Arm W/Assembly	1
17	25727	Jockey Axle Outer Spacer	1
18	45140	M16 Nyloc Nut	1
19	25746	Jockey Drive Swing Guard	1
20	45156	M6 H/D Flat Washer Z/P	2
21	45164	M6 Spring Washer	2
22	44951s	M6 x 16 Grade 8.8 Z/P S/Screw	2
23	45119	M16 Grade 8.8 Hex Half-Nut Z/P	1
24	23376	Chain Tensioner Anchor 30 Ext	1
25	22523	Torsion Spring Right Hand	1
26	22535	Chain Tension Roller	1
27	23373	Chain Tensioner Short L/H Assy	1
28	45043	M16 x 65 Grade 8.8 Z/P Bolt	1
29	25725	Jockey Arm Pivot Spacer	2
30	43939	Bearing 6205	2
31	25729	Jockey Arm Pivot Outer Spacer	1
32	45163	M24 H/D Flat Washer Z/P	1
33	25742	38T Sprocket 1/2" x 25mm Bore	1
34	43386	Bearing YET205 25mm	3
35	30359	Bearing Housing PF52 (1 housing = 2 flanges)	3
36	22050	Crank Adapter Assembly	1
37	63127	15T Double Sprocket 1/2"P 25mm	1
38	63126	Drive Pedestal Main Shaft	1
39	72913	Sensor Mounting bracket	1
40	48036	Dia.14-27mm Hose Clip Stainless Steel	1
41	72951	Prox Trigger	1
42	-	Proximity Sensor M12 (AA-487)	1
43	45002s	M10 x 25 Grade 8.8 Z/P S/Screw	1
44	45152	M10 Light Flat Washer Z/P	1
45	45138	M10 Nyloc Nut	1

# 'Renovator Classic Air' Chains & Tensioners

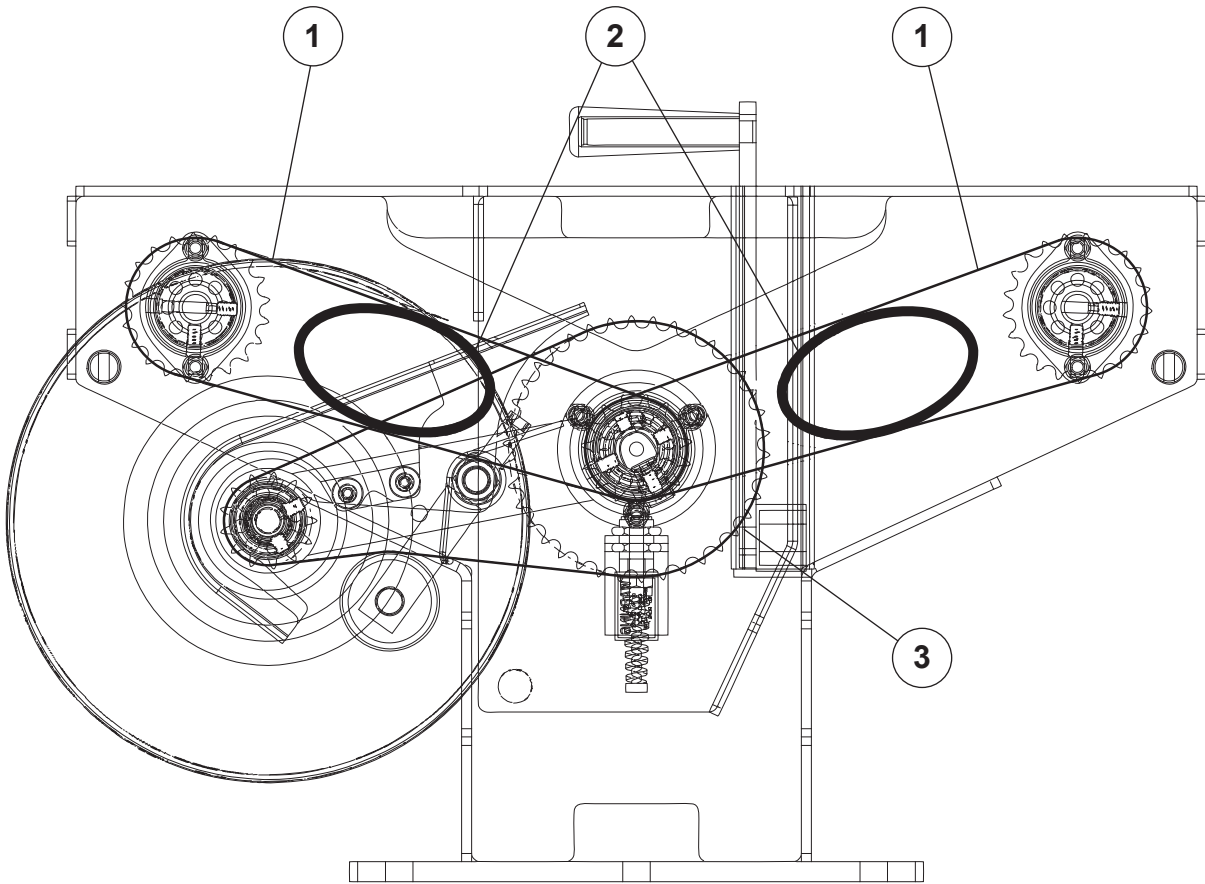

For Jockey Chain Tensioner see  
items 23 to 28 on previous page



# 'Renovator Classic Air' Chains & Tensioners

ITEM	PART No.	DESCRIPTION	QTY
1	63125	1/2" BS Chain x 63 Links	2
2	44014	Plastic Chain Tensioner	2
3	24103	1/2" BS Chain x 61 Links	1
4	43388	1/2" P Joiner Link	3

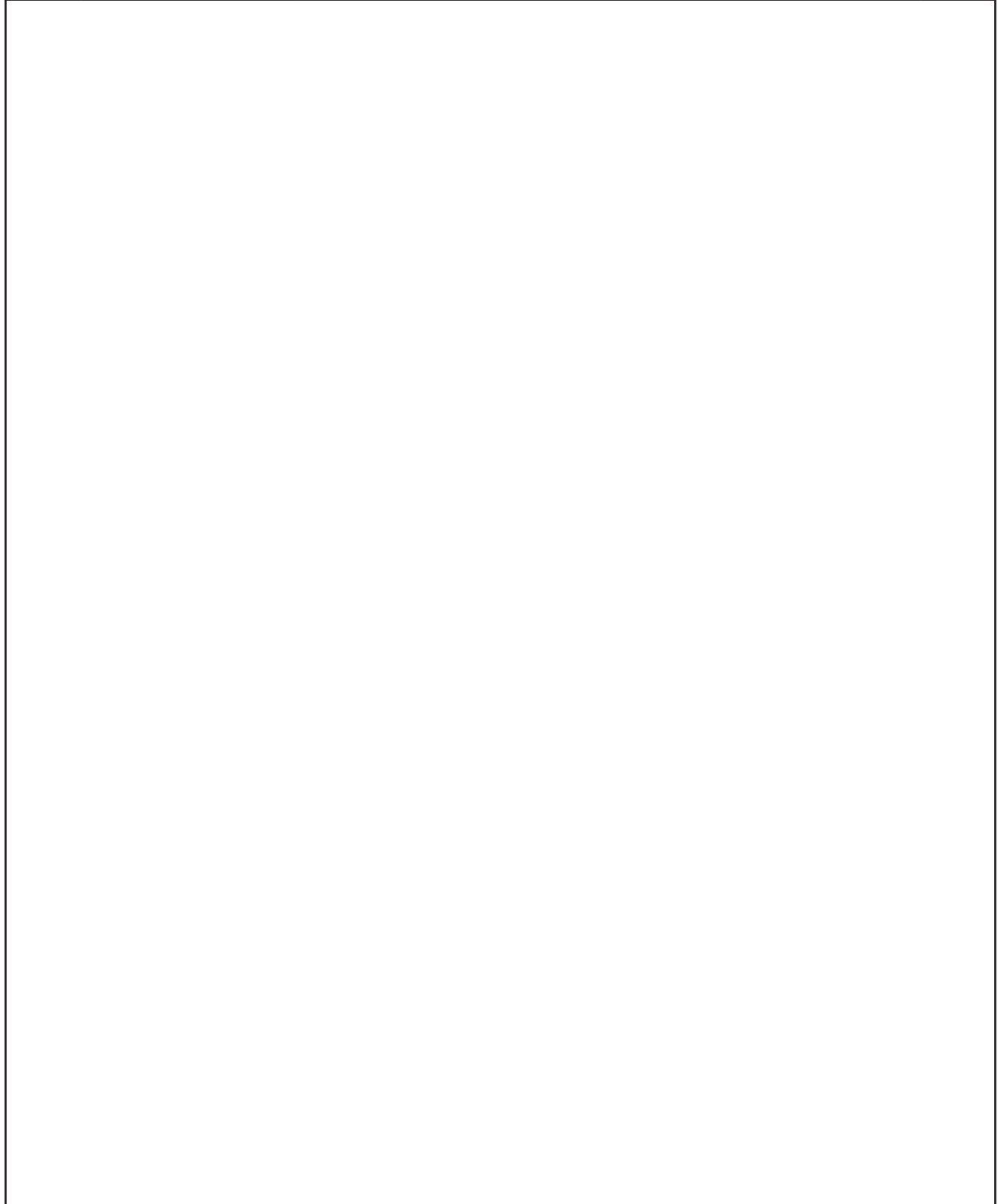

# 'Renovator Classic Air' Driveshafts (Metering)

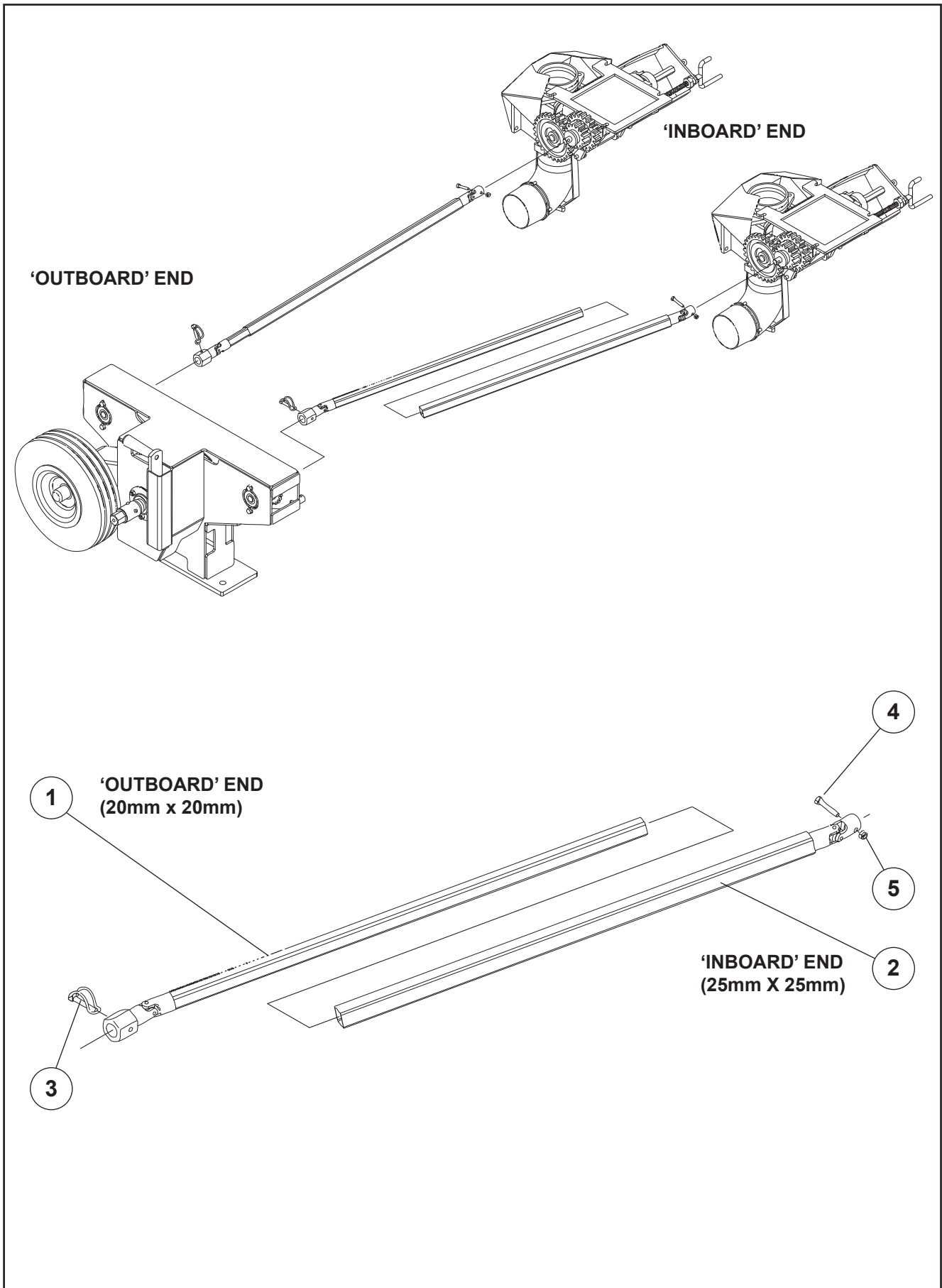

# 'Renovator Classic Air' Driveshafts (Metering)

ITEM	PART No.	DESCRIPTION	QTY
1	63230	O/Board Universal Shaft W/Assy	2
2	63231	InBoard Universal Shaft W/Assy	2
3	47615	6 x 40 Pipe Lynch Pin	2
4	44957SS	M6 x 35 304 S/Steel Bolt	2
5	45136SS	M6 Nyloc Nut Grade 316 S/S	2
6	44039	UJ Coupling Rubber Boot (not shown)	4

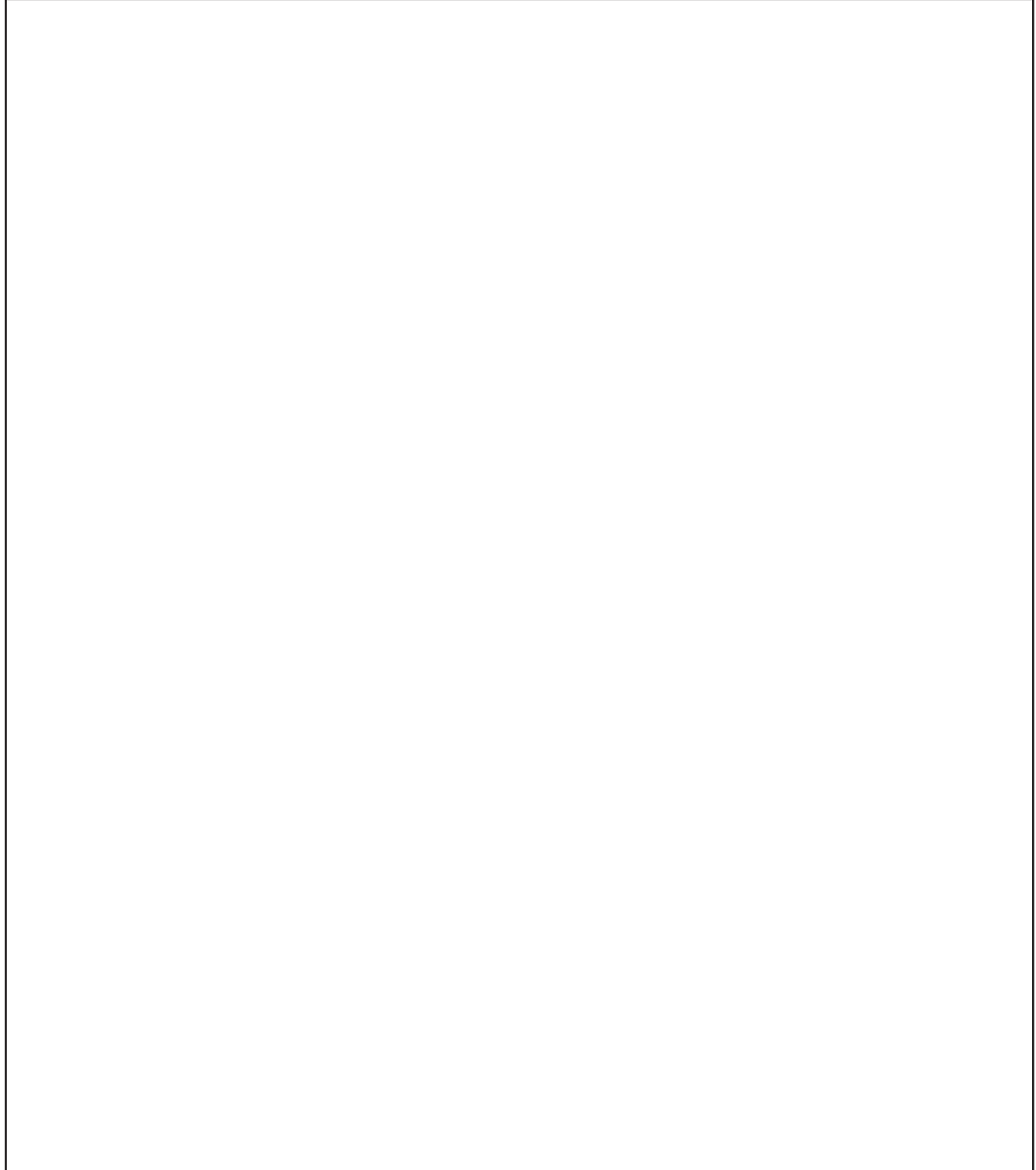

# 'Renovator Classic Air' Adapter Frame

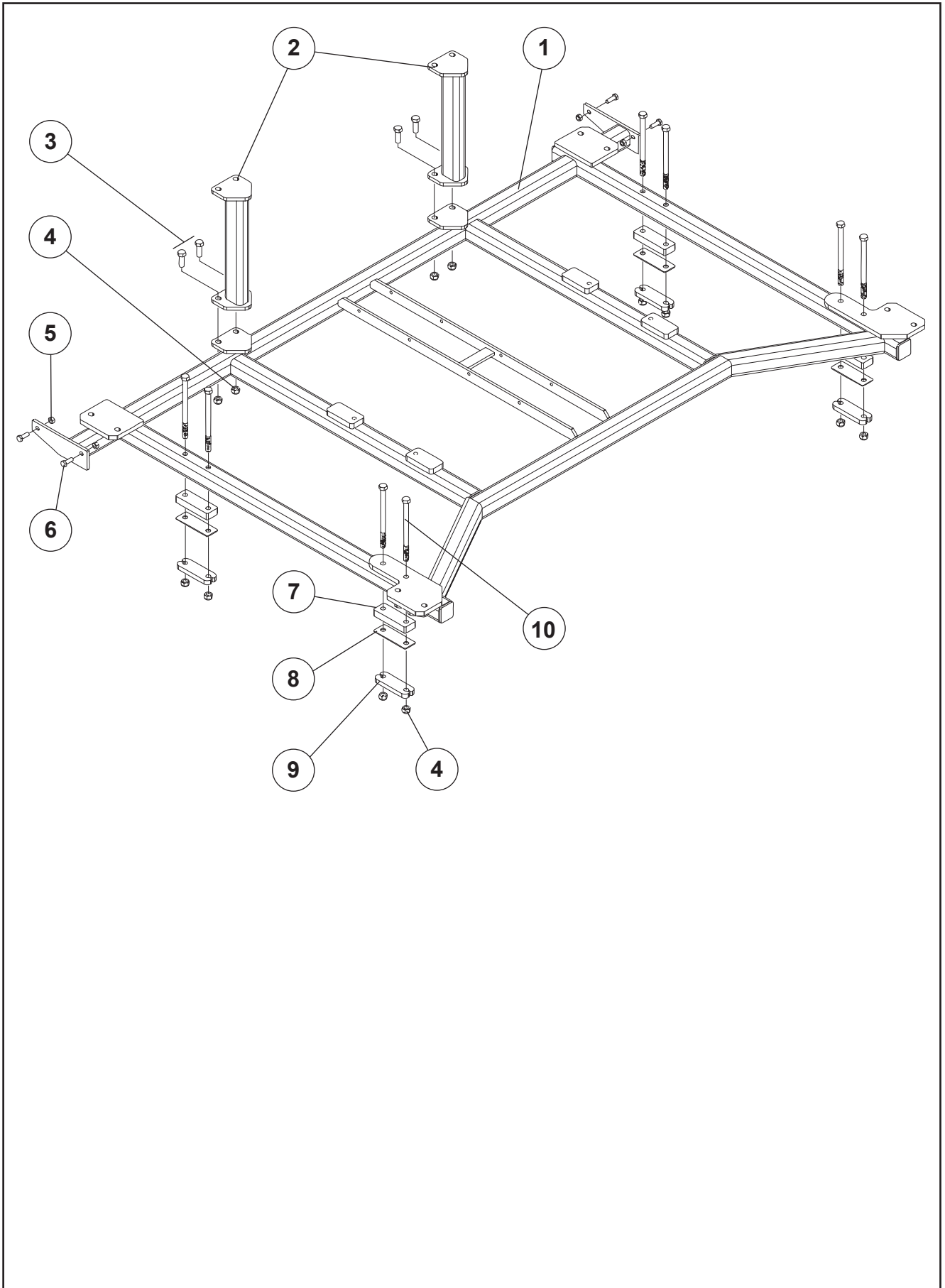

# ‘Renovator Classic Air’ Adapter Frame

ITEM	PART No.	DESCRIPTION	QTY
1	64401	Adapter Frame	1
2	64417	Foot Stand W/Assy	2
3	45039	M16 x 45 Grade 8.8 Z/P Bolt	4
4	45140	M16 Nyloc Nut	12
5	45139	M12 Nyloc Nut	4
6	45020s	M12 x 35 Grade 8.8 Z/P S/Screw	4
7	63835	Clamp 50 x 25	4
8	64407P	Shim Profile	4
9	21690	Clamp Plate (75 x 75 RHS)	4
10	45057	M16 x 230 Grade 8.8 Z/P Bolt	8

# 'Renovator Classic Air' Seedbox Frame

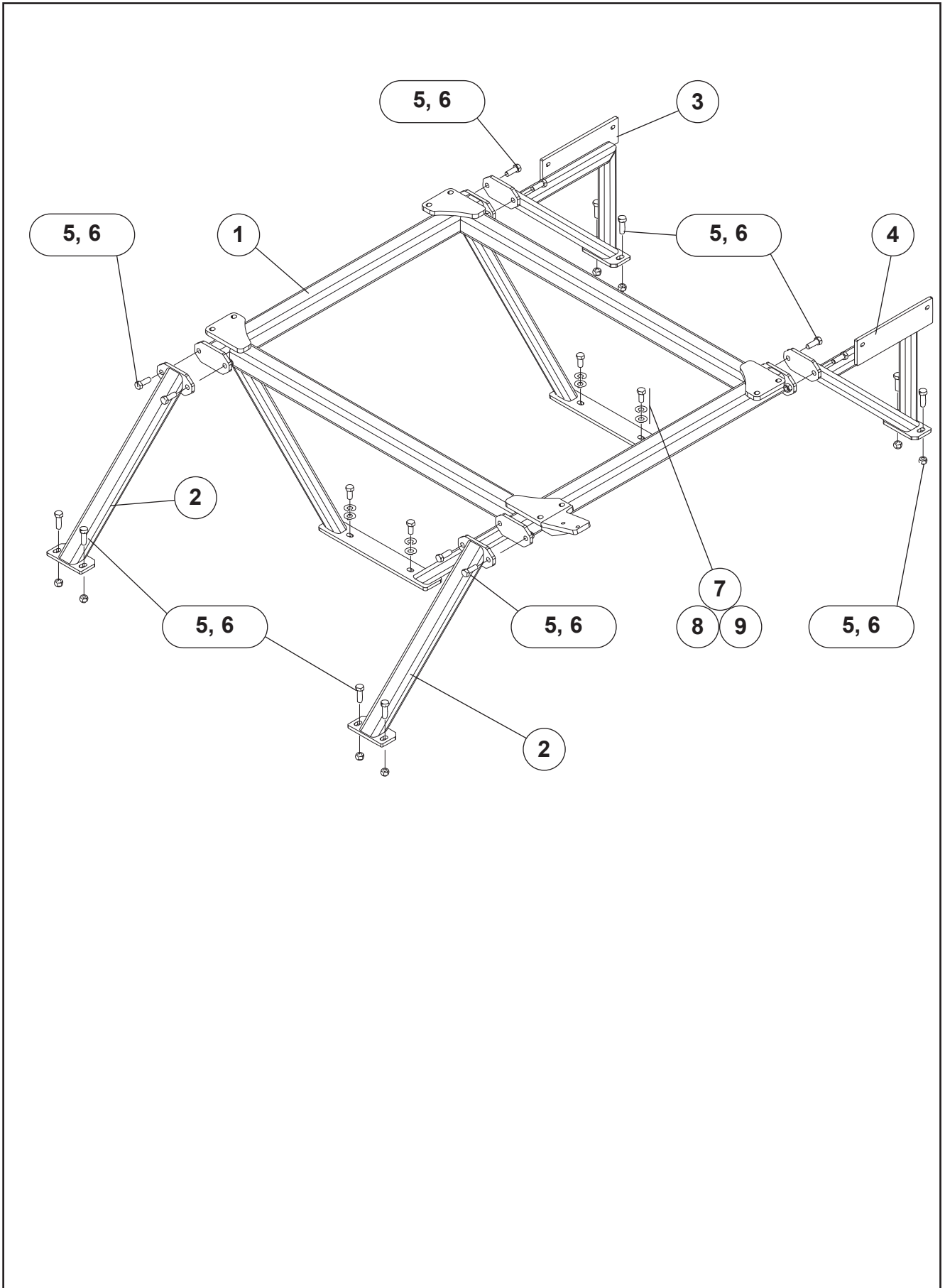

# ‘Renovator Classic Air’ Seedbox Frame

ITEM	PART No.	DESCRIPTION	QTY
1	64116	Hopper Mount Frame W/Assy	1
2	63195	Side Support W/Assy	2
3	63199	RH Frame Brace Front	1
4	63205	RH Frame Brace Rear	1
5	45039	M16 x 45 Grade 8.8 Z/P Bolt	8
6	45140	M16 Nyloc Nut	22
7	45037	M16 x 35 Grade 8.8 Z/P Bolt	4
8	45168	M16 Spring Washer Z/P	4
9	45160	M16 HD Flat Washer Z/P	4

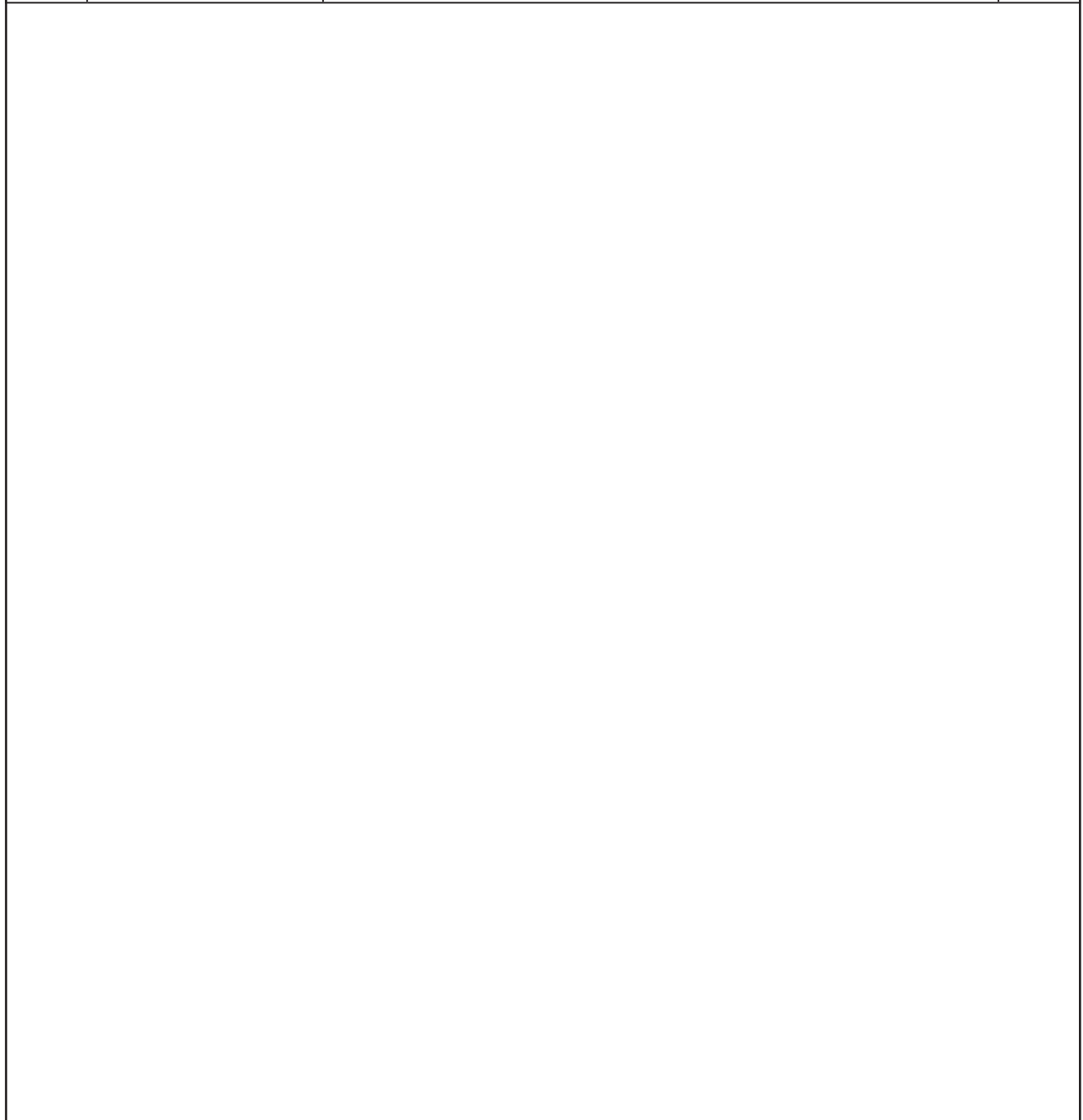

# 'Renovator Classic Air' Footboard & Ladder

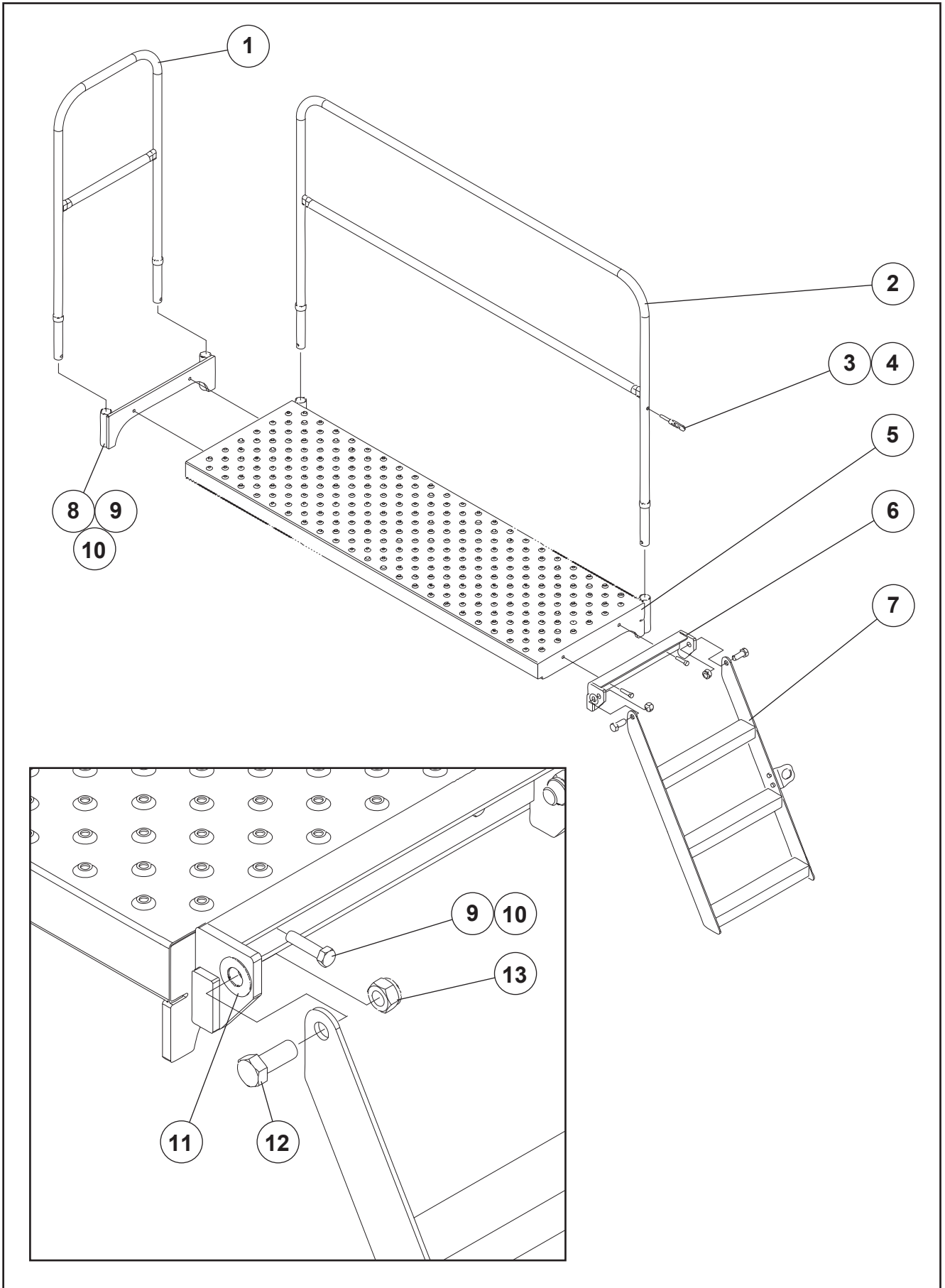



# 'Renovator Classic Air' Footboard & Ladder

ITEM	PART No.	DESCRIPTION	QTY
1	60163	End Guard Rail W/Assy	1
2	61705	Side Guard Rail W/Assy	1
3	43757	Drop Lock	1
4	45138	M10 Nyloc Nut	1
5	61700	RH Footboard Assembly	1
6	60170	Footboard Step Bracket W/Assy	1
7	63219	Ladder Assembly	1
8	64122	Guard Rail Multi-Purpose Frame	1
9	45023	M12 x 50 Grade 8.8 Z/P Bolt	8
10	45139	M12 Nyloc Nut	8
11	45155	M20 Light Flat Washer Z/P	2
12	45062	M20 x 50 Grade 8.8 Z/P Bolt	2
13	45141	M20 Nyloc Nut	2

# 'Renovator Classic Air' Seed/Fert Box

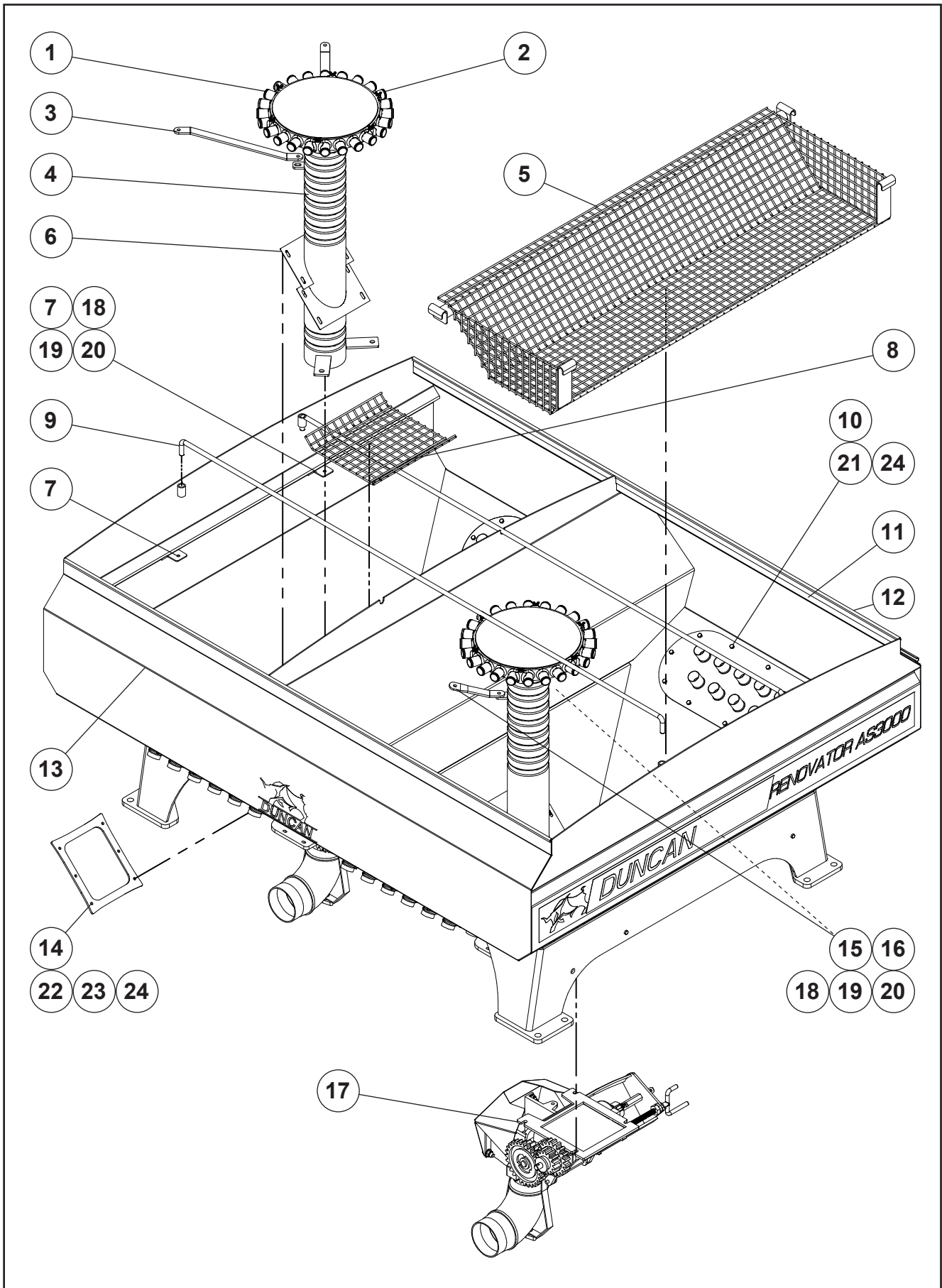

# ‘Renovator Classic Air’ Seed/Fert Box

ITEM	PART No.	DESCRIPTION	QTY
1	44064	Air Distributor Head 24 Outlet	2
2	44059	Blanking Plug Seed Distr Head	10
3	72787	Radial Brace Tube Top Support	2
4	44071	Tube	2
5	64427	Mesh Frame W/Assy	1
6	63166P	Outlet Half Moon Flange Profile	4
7	72786	Radial Wall Bracket	2
8	63167	Mesh Grid Filter Hopper Bottom	1
9	63182	Hopper Cover Support Rod	2
10	63194	9 Hole Tube Inset Panel W/Assy	2
10	63175	10 Hole Tube Inset Panel W/Assy	2
11	63150	MS Hopper W/Assy	1
12	43373	Edgetrim Black (per metre)	-
13	63173	Cover Holding Extrusion	-
14	63260P	Hopper Gasket Support Profile	2
15	72789	Rh Radial Brace Short	1
16	72788	Lh Radial Brace Short	1
17	Refer Page 66	Metering Unit	2
18	45412sss	M8 X 25 S/Screw St. Stl.	-
19	45151ss	M8 Light Flat Washer 304 S/S	-
20	45137ss	M8 Nylock Nut Grade 304 S/S	-
21	44951sss	M6 x 16 316 S/S S/Screw	-
22	45402sss	M6 X 20 Grade 304 Ss S/Screw	-
23	45150SS	M6 Light Flat Washer 304 S/S	-
24	45136SS	M6 Nylock Nut Grade 304 S/S	-
25	43430	Plastic lashing Hooks (not shown)	11
26	63174	Ripstop Hopper Cover (not shown)	1
27	63251	Air Delivery Hose Long (not shown)	1
28	63252	Air Delivery Hose Short (not shown)	1
29	44167	32mm Nylaflow Air Seeder Hose	-
30	43691	38mm Nylaflow Air Seeder Hose	-

# 'Renovator Classic Air' Metering Unit

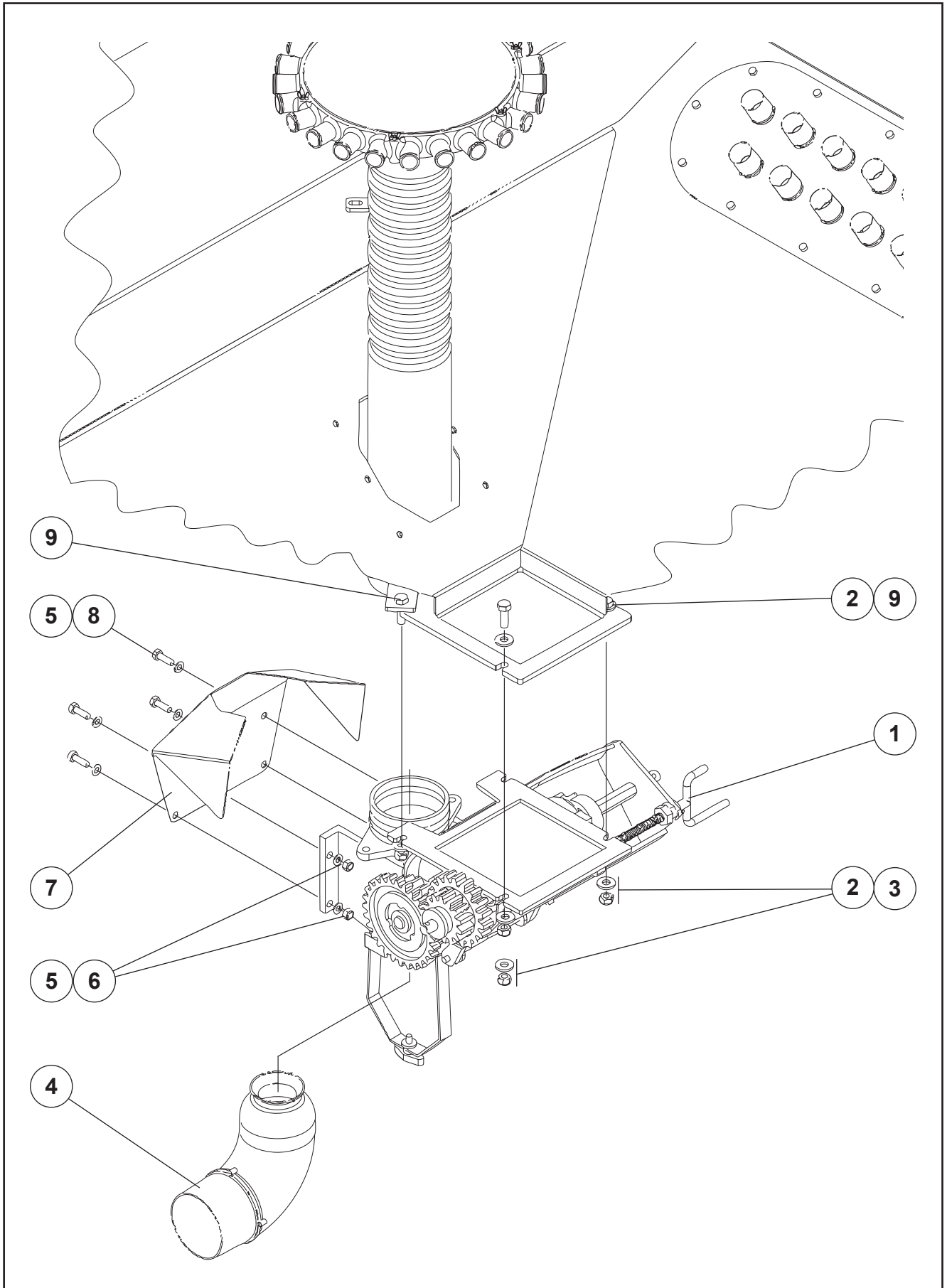

# 'Renovator Classic Air' Metering Unit

ITEM	PART No.	DESCRIPTION	QTY
1	44063	Metering Device	1
2	45152	M10 Light Flat Washer Z/P	6
3	45138	M10 Nyloc Nut	4
4	44068	Elbow	1
5	45151	M8 Light Flat Washer Z/P	8
6	45137	M8 Nyloc Nut	4
7	63259	Cover	1
8	44993s	M8 x 25 Grade 8.8 Z/P S/Screw	4
9	45004	M10 x 35 Grade 8.8 Z/P Bolt	4
10	44101	Bracket (spare)	-
11	44099	Toggle (spare)	-

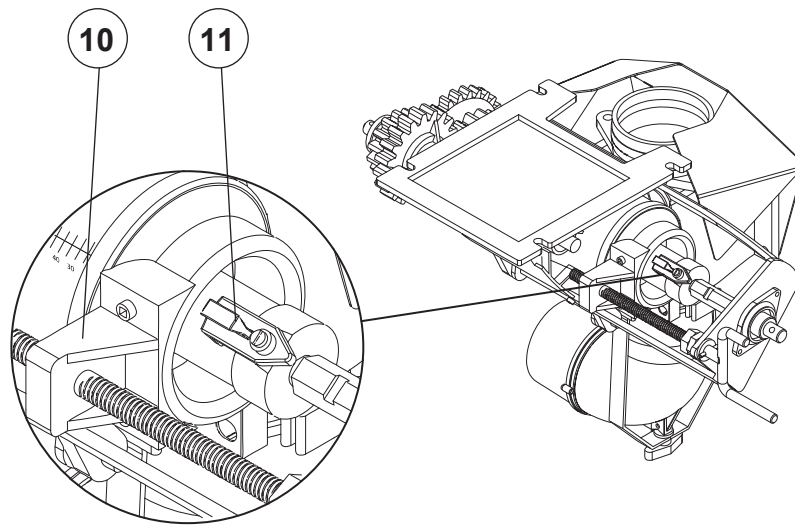

# 'Renovator Classic Air' Fan & Air Hoses

ITEM	PART No.	DESCRIPTION	QTY
1	44017	Blower 15 Series	1
2	44992s	M8 x 20 Grade 8.8 Z/P S/Screw	6
3	44018	Flanged Blower Manifold Splitter	1
4	45137	M8 Nyloc Nut	6
5	45139	M12 Nyloc Nut	2
6	45032	M12 x 110 Grade 8.8 Z/P Bolt	2
7	63237	Fan Support Block	1
8	44144	Bearing Block Opspr2 (between motor and fan)	1
9	44019	Galtech 11cc Hydraulic Motor	1
10	63251	Air Delivery Hose Long (not shown)	1
11	63252	Air Delivery Hose Short (not shown)	1

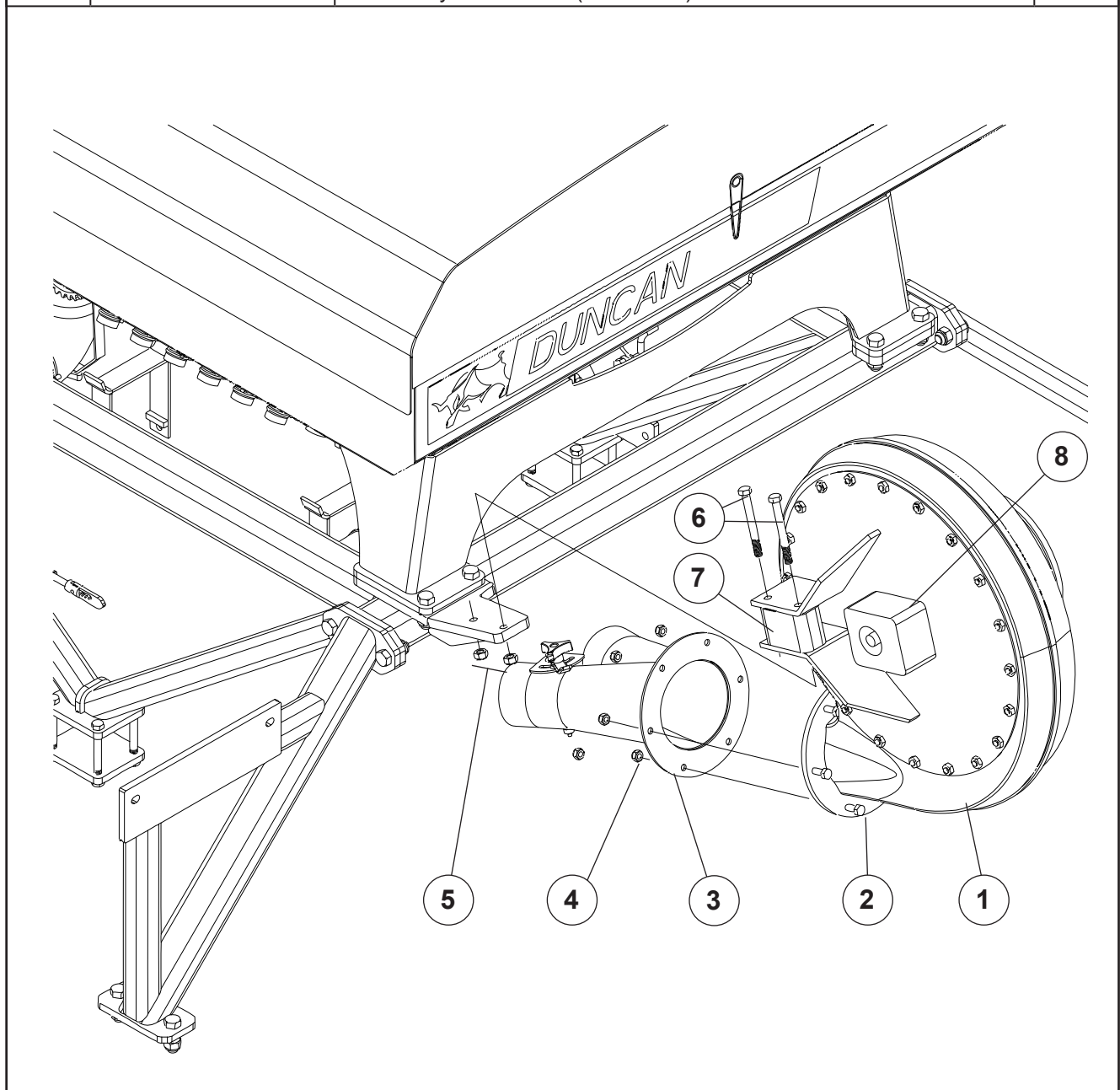

# 'Renovator Classic Air' Fan & Air Hoses

ITEM	PART No.	DESCRIPTION	QTY
-	<b>44060k</b>	<b>FAN MOTOR HOSE KIT contains items 1 to 13:-</b>	
1	44072	Hydraulic Hose (4.0m)	1
2	44073	Hydraulic Hose (3.38m)	1
3	44074	Hydraulic Hose (4.15m)	1
4	44075	7/8" UN'O x 1/2" BSPPM Nipple	1
5	48094	7/8" UN'O'x 3/4" BSP Nipple	1
6	44078	9/16" JICF x 1/4" BSPM 90°	1
7	44080	3/4" BSP Female Q.R. Coupling	1
8	44081	3/4" BSP Male Q.R. Coupling	1
9	43147	1/2" BSP Male Q.R Coupling	1
10	43617	1/2" Female Dust Cover	1
11	44128	3/4" Male Dust Cover	1
12	43148	1/2" BSP Female Q.R. Coupling	1
13	43618	1/2" Male Probe Dust Cover	1
14	44019	Galtech 11cc Hydraulic Motor (Spare parts listed below)	1
15	44144	Bearing Block Opspr2 (between motor and fan)	1
16	44529	Splined Coupling (Blowr Motor)	1
17	44149	Shaft Seal 18 X 30 X 7 - 2 Sp	1
18	44145	Hyd Motor Seal Kit For 44016K	1
19	44351	Flow/Chk Valve For Blowr Motor	1

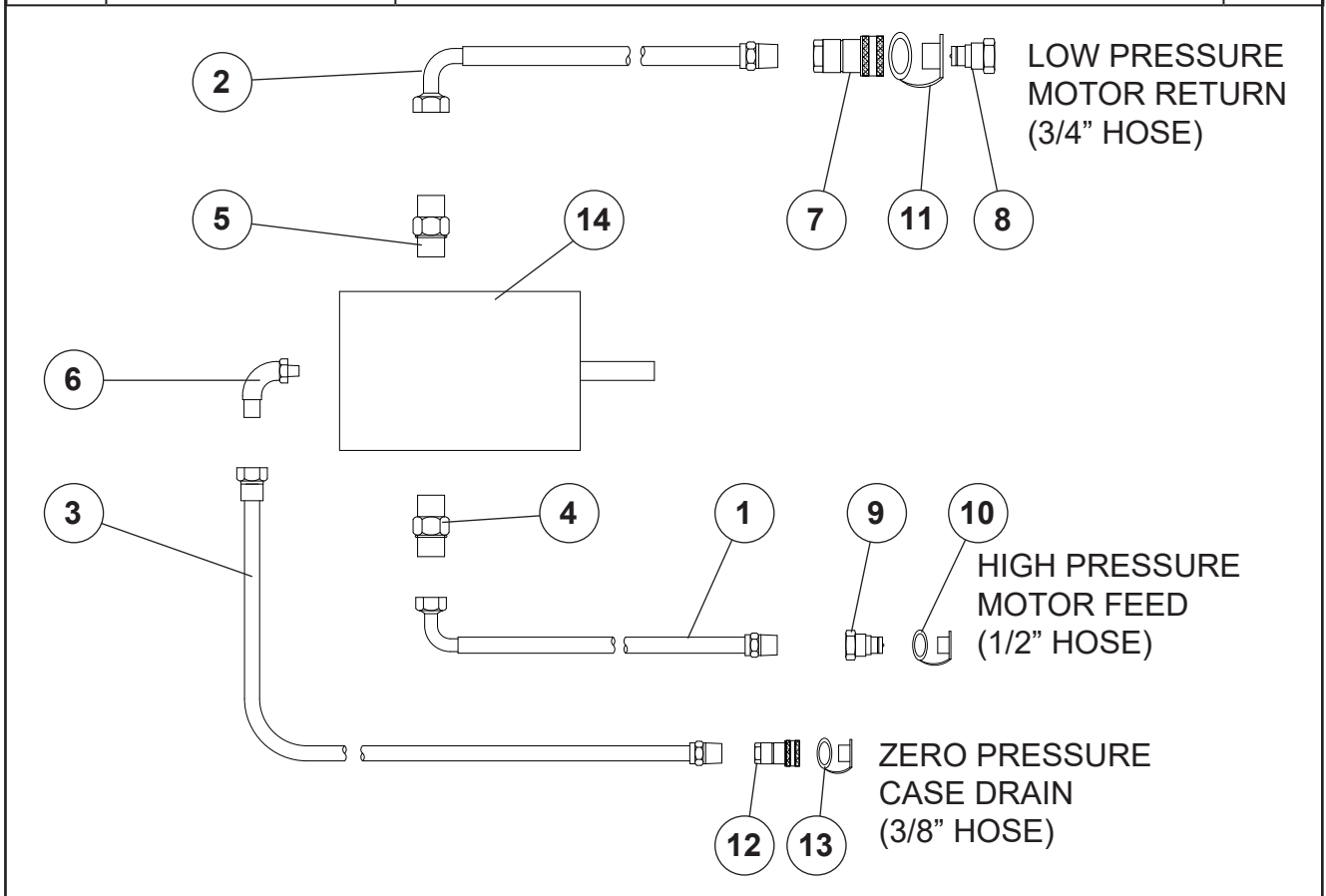

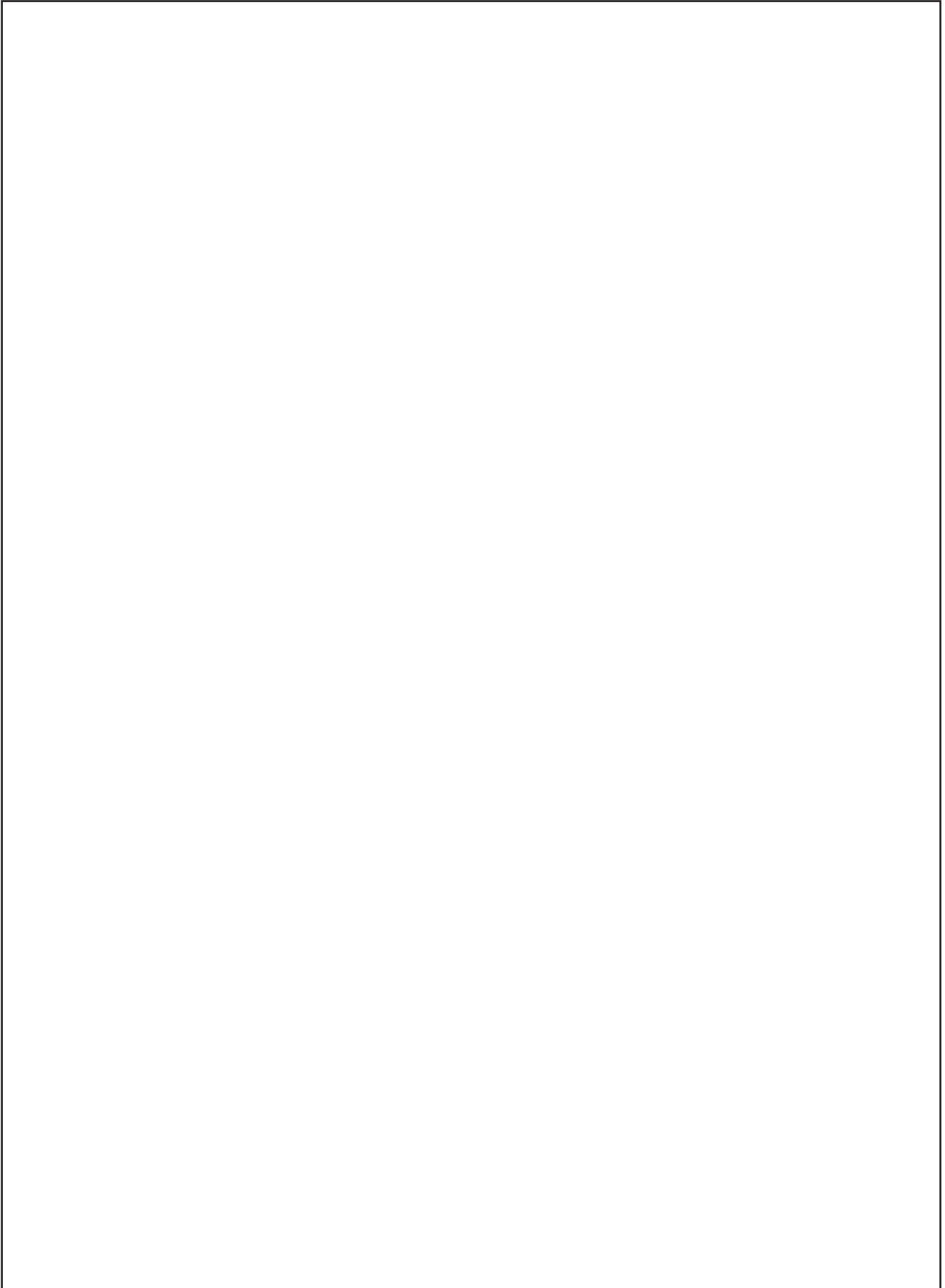

# 'Renovator Classic Air'



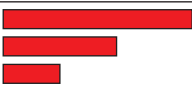

# 'Renovator Classic Air' Hose Connection Colours

Used On...	Hose Function	Wrap Colour	Length/Diameter (mm)	Material Part No.	Description
AS3000/3500/4000, DD30/35/45/50/55, AS53/61	Blower Pressure	RED	350 long Ø25	48089	25mm Coiled Hose Armour/M (RED)
	Blower Return	RED	250 long Ø32	48091	32mm Coiled Hose Armour/M (RED)
	Blower Case Drain	RED	150 long Ø20	48086	20mm Coiled Hose Armour/M (RED)
AS3000/3500/4000, DD30/35, AS53/61	Wheels Lift	BLUE	250 long Ø20	48085	20mm Coiled Hose Armour/M (BLUE)
	Wheels Lower	BLUE	150 long Ø20	48085	20mm Coiled Hose Armour/M (BLUE)
DD45/50/55	Wheels Lift	BLUE	250 long Ø25	48088	25mm Coiled Hose Armour/M (BLUE)
	Wheels Lower	BLUE	150 long Ø25	48088	25mm Coiled Hose Armour/M (BLUE)
AS53/61	Wings Fold Up	YELLOW	250 long Ø20	48087	20mm Coiled Hose Armour/M (YELLOW)
	Wings Fold Down	YELLOW	150 long Ø20	48087	20mm Coiled Hose Armour/M (YELLOW)
DD45/50/55	Wings Fold Up	YELLOW	250 long Ø25	48090	25mm Coiled Hose Armour/M (YELLOW)
	Wings Fold Down	YELLOW	150 long Ø25	48090	25mm Coiled Hose Armour/M (YELLOW)

	Blower <b>RED</b>	Pressure Return Case Drain		Hose Connection Colours
	Wheels <b>BLUE</b>	Lift Lower		
	Wings <b>YELLOW</b>	Fold Up Fold Down		

# 'Renovator Classic Air' Weighing Kit

ITEM	PART No.	DESCRIPTION	QTY
1	43455	Electronic Scales Model Nwth10	1
2	43456	Desktop Calculator 86632994	1
3	43457	Sistema Klip It Plastic Container	2
4	43975	HD Cardboard Box 380X275x140	1
5	67398	Owners Manual Renovator Classic Air	1

# 'Renovator Classic Air' Jackal

ITEM	PART No.	DESCRIPTION	QTY
KIT	44026K	Contains the following:	
1	44027	Jackal v3.5 Monitor and Control Speed, Area Meter and Fan	1
2	44037	Owner's Manual Jackal v3.5 Monitor and Control Speed	1
3	44028	Window Mount AH-407	1
4	44576	11 way Terminal Block P322 Grey	1
5	44146	11 way Terminal Block P321 Green	1
6	-	Cable S/Assy Jackal v3.5 (2 x 3way)	1
7	44029	Power Cable AC-105	1
8	48027	7.5m Cable (3 way) (AC-487-7,5m)	2
9	-	Proximity Sensor M12 (AA-487)	2

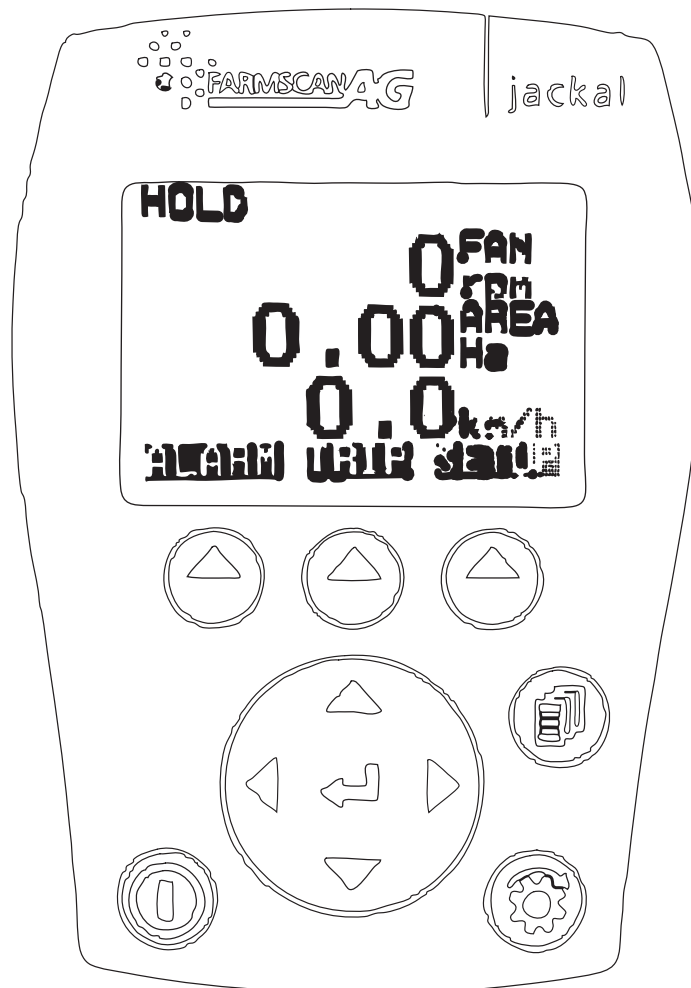

# 'Renovator Classic Air' Lighting (Optional)

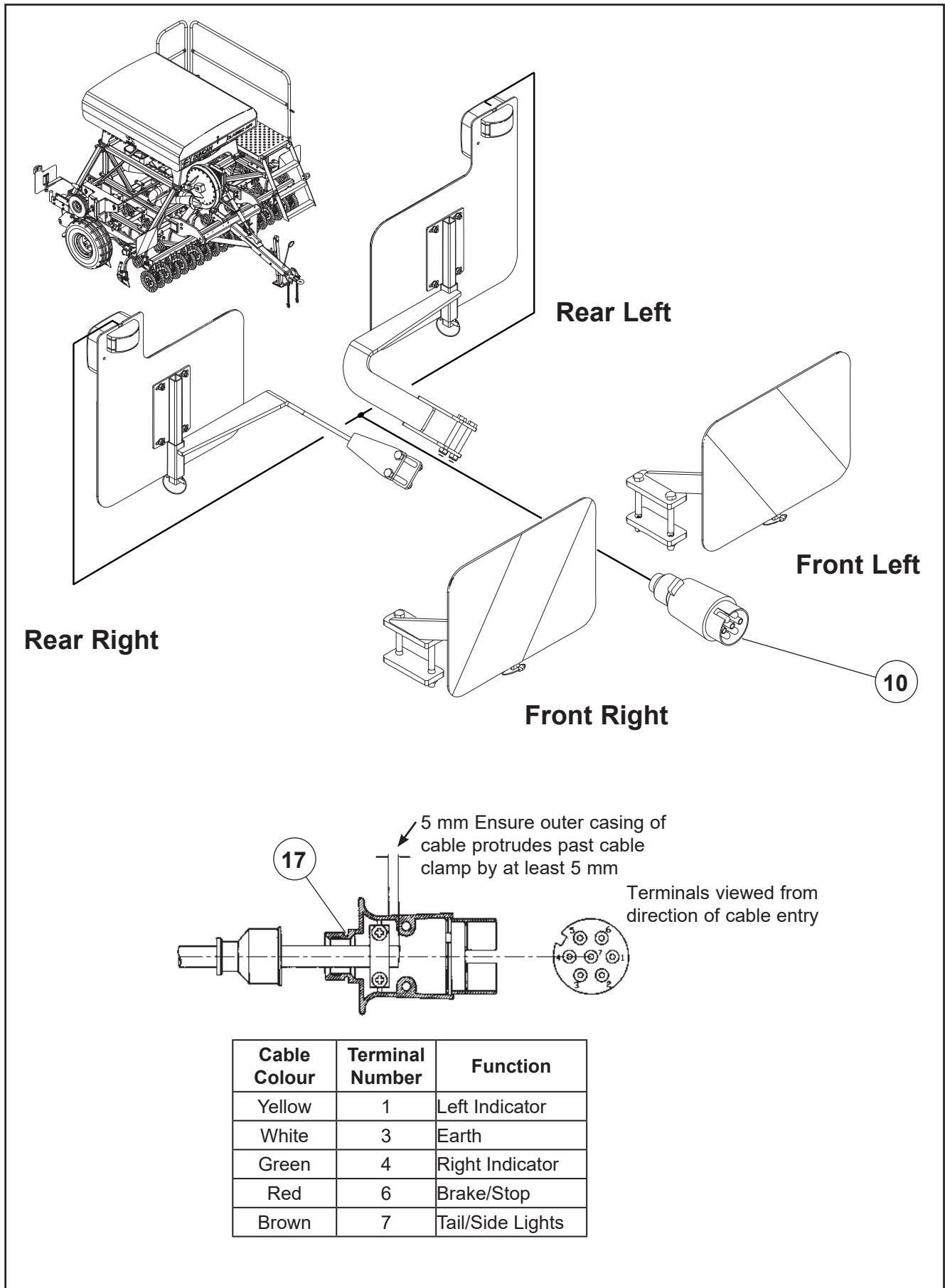

# 'Renovator Classic Air' Lighting (Optional)

ITEM	PART No.	DESCRIPTION	QTY
KIT	TBC	Contains items 1 to 20:	
1	45664	Hazard Decal Full Set	2
2	61718P#	Hazard Panel Front Profile	2
3	61719P#	Hazard Panel Rear Profile	2
4	61715	Viz Plate Holding Bracket	4
5	64128	FR-RH Viz Frame (Front right)	1
6	64127	FR-LH Viz Frame (Front left)	1
7	61709	RR-RH Viz Frame	1
8	61710	RR-LH Viz Frame	1
9	64125P#	Viz Frame Clamp Plate	2
10	60881	Loom (includes Plug and LED lights prewired)	1
11	45033	M12 x 120 Grade 8.8 Z/P Bolt	8
12	45139	M12 Nyloc Nut	8
13	45013	M10 x 80 Grade 8.8 Z/P Bolt	4
14	45138	M10 Nyloc Nut	4
15	44951s	M6 x 16 Grade 8.8 Z/P Set Screw	16
16	45150	M6 Light Flat Washer	16
17	45136	M6 Nyloc Nut	16
18	43675	1/4" X 1 1/2" Linch Pin	4
19	43333	Plastic Tie Strap	12
20	47620	"P" Clip	4
21	43437	Trailer Round Connector Plug (spares)	1

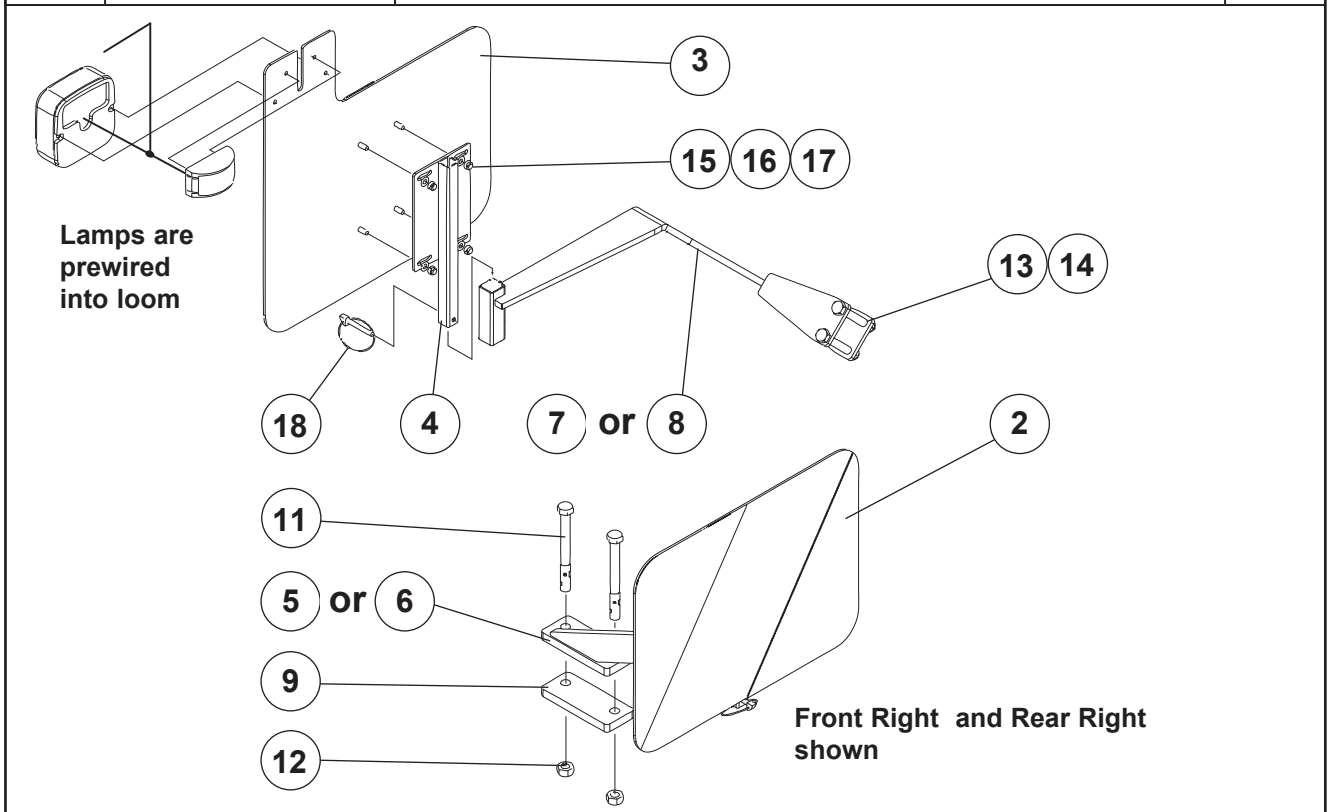

# 'Renovator Classic Air' (Optional) Disc Opener

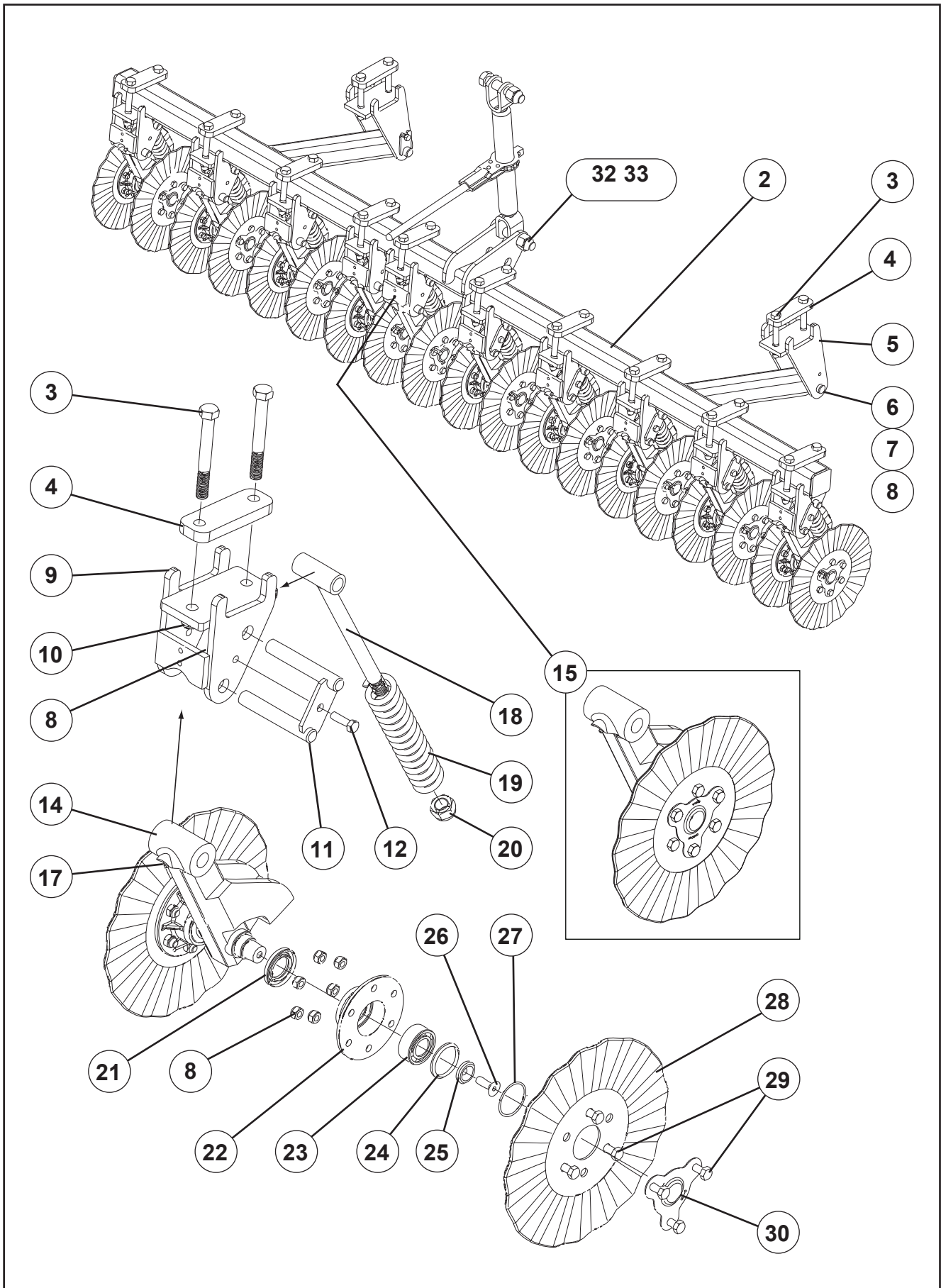

# 'Renovator Classic Air' (Optional) Disc Opener

ITEM	PART No.	DESCRIPTION	QTY
1	C/RCDO	Disc Opener Complete	1
2	62040	Disc Opener Frame	1
3	45051	M16 X 130 Class 8.8 Bolt	24
4	21690	Clamp Plate	12
5	25562	Disc Opener Frame Support Welded Assy	2
6	21245	Pivot Pin Assy	2
7	45001s	M10 x 20 Class 8.8 Set Screw	2
8	45138	M10 Nyloc Nut	108
9	60460	Mounting Bracket	10
10	45140	M16 Nyloc Nut	24
11	21244	Double Pivot Pin Assembly	10
12	45004	M10 x 35 Class 8.8 Bolt	10
13	60455	Double Disc Assembly	9
14	60459	Double Axle Arm Welded Assy	9
15	60452	Single Disc Assembly LH	1
16	60456	Single Axle Arm Welded Assy	1
17	43118	Grease Nipple Straight	10
18	26310	T Bolt Spring Rod	10
19	60294	Disc Opener Spring	10
20	45141	M20 Nyloc Nut	10
21	45650	Seal	19
22	60466	Housing	19
23	45652	Bearing	19
24	60469	Bearing Retainer (Outer Race)	19
25	60444	Bearing Retainer (Inner Race)	19
26	45662	M10 x 30 CSK Screw	19
27	45653	O Ring Seal	19
28	22035	Fluted Disc 318mm Dia.	19
29	45002s	M10 x 25 Class 8.8 Set Screw	114
30	60468	Cover Plate Stainless Steel	19
31	43395	H/D Ratchet Turnbuckle	1
32	47254	Bolt 1" UNF x 5" HT	2
33	47552	1" UNF Nyloc Nut	4

# 'Renovator Classic Air' (Optional) Disc Opener

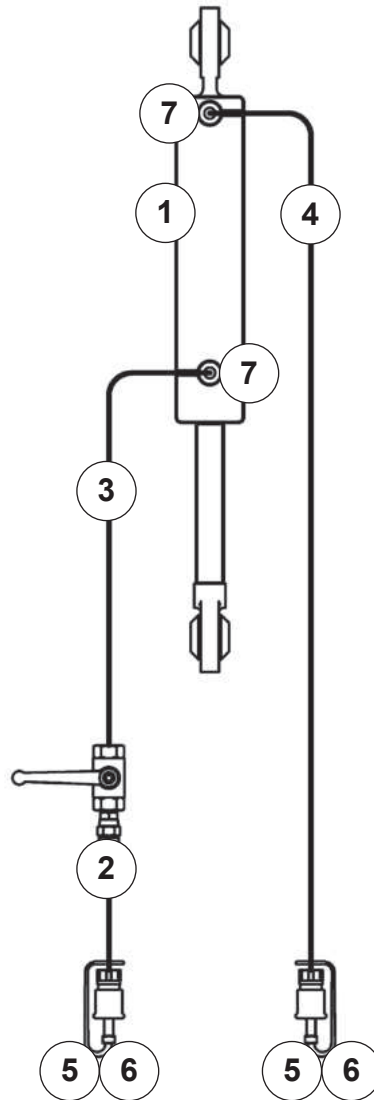
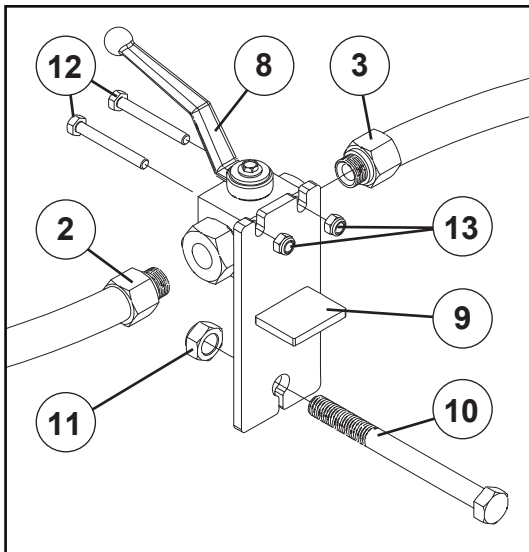



# 'Renovator Classic Air' (Optional) Disc Opener

ITEM	PART No.	DESCRIPTION	QTY
1	45655	Hydraulic Cylinder	1
2	60874	Hydraulic Hose 2.70m	1
3	26695	Hydraulic Hose 0.60m	1
4	26696	Hydraulic Hose 3.5m	1
5	43147	1/2" BSP Quick Release Coupling	2
6	43617	Dust Cover	2
7	43280	3/4" UNO to 3/8" BPSM Nipple	2
8	43393	3/8" BSP S/S Ball Valve	1
9	60856	Hydraulic Valve Support Assembly	1
10	45035	M12 x 140 Grade 8.8 Bolt	1
11	45139	M12 Nyloc Nut	1
12	44957	M6 x 50 Bolt	2
13	45136	M6 Nyloc Nut	2
14	47254	1.0 UNF X 5.0" HT Bolt	2
15	47552	1.0"UNF Nyloc Nut	2

NOTE: Items 1 to 13 may be ordered as a kit. Part number 60076K

# 'Renovator Classic Air' Row Marker (Optional)

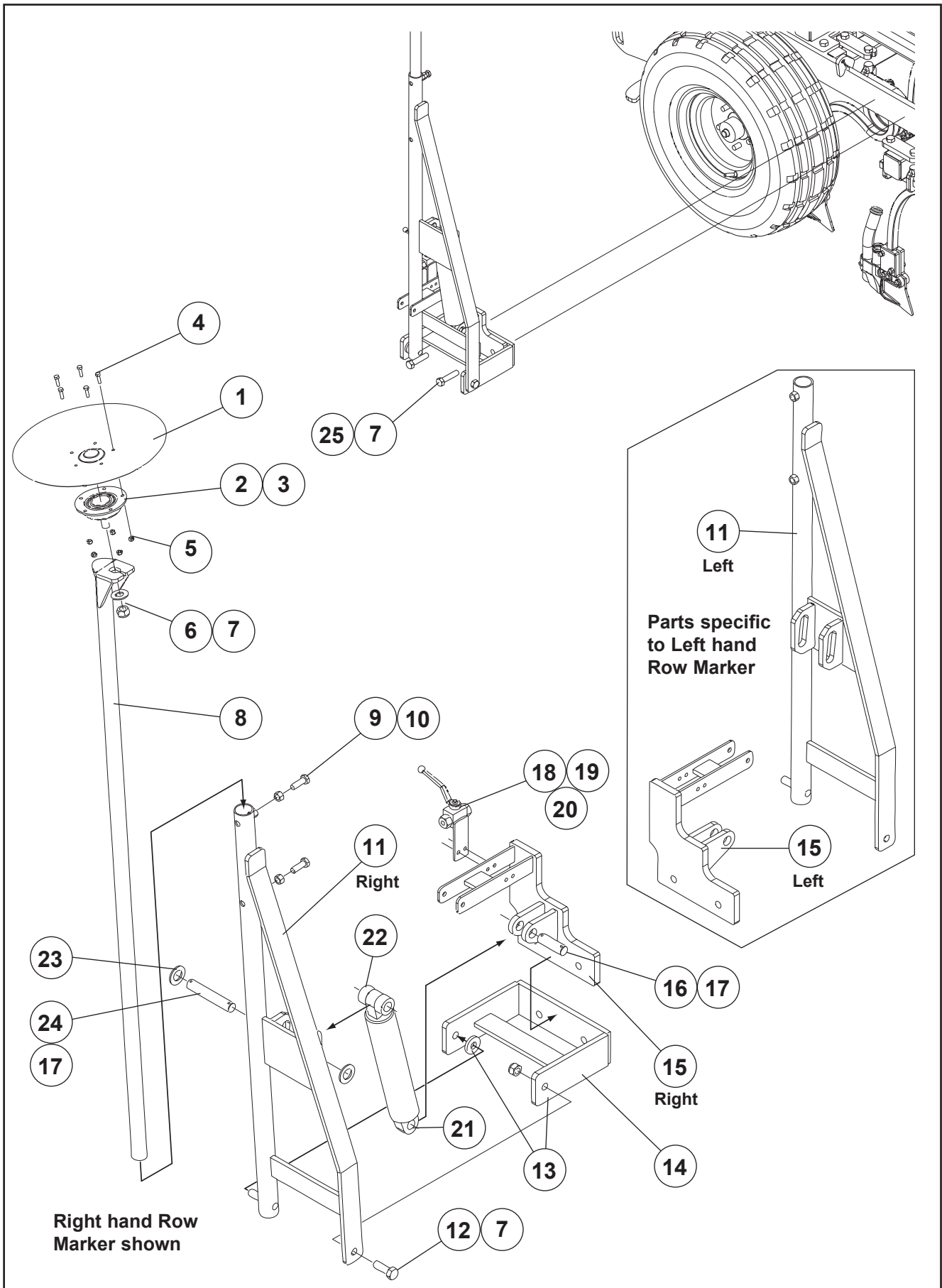

# 'Renovator Classic Air' Row Marker (Optional)

ITEM	PART No.	DESCRIPTION	QTY
KIT	61725K	Row Marker Kit:-	
1	10192	Disc	1
2	23535	Bearing Stud	1
3	14443	Bearing Housing	1
4	44952s	M6 x 20 Grade 8.8 Z/P S/Screw	6
5	45136	M6 Nyloc Nut	6
6	45160	M16 H/D Flat Washer Z/P	1
7	45140	M16 Nyloc Nut	2
8	23542	Disc Arm Assembly	1
9	45131	M12 Grade 8.8 Hex Nut Z/P	2
10	45020s	M12 x 35 Grade 8.8 Z/P S/Screw	2
11	61735	LH Frame W/Assembly	1
11	61736	RH Frame W/Assembly	1
12	45039	M16 x 45 Grade 8.8 Z/P Bolt	1
13	22416	Spacer	4
14	61726	Hinge Frame W/Assembly	2
15	61730	L/H Ram Mount W/Assembly	1
15	61731	R/H Ram Mount W/Assembly	1
16	23589	Ram Pivot Pin	2
17	45272	R Clip (S12) OR (AG7)	8
18	61749	Ball Valve Mount W/Assy	1
19	44962	M8 x 30 Grade 8.8 Z/P Bolt	2
20	45137	M8 Nyloc Nut	2
21	61751	D/A Ram 2" x 1" x 8" Compact S	2
22	61740	Frame Ram Spacer	4
23	45163	M24 H/D Flat Washer Z/P	4
24	61742	Ram Pivot Pin 126 Long	2
25	45044	M16 x 70 Grade 8.8 Z/P Bolt	4

*Hydraulic hoses and component detail are shown on the next page.*

# 'Renovator Classic Air' Row Marker (Optional)

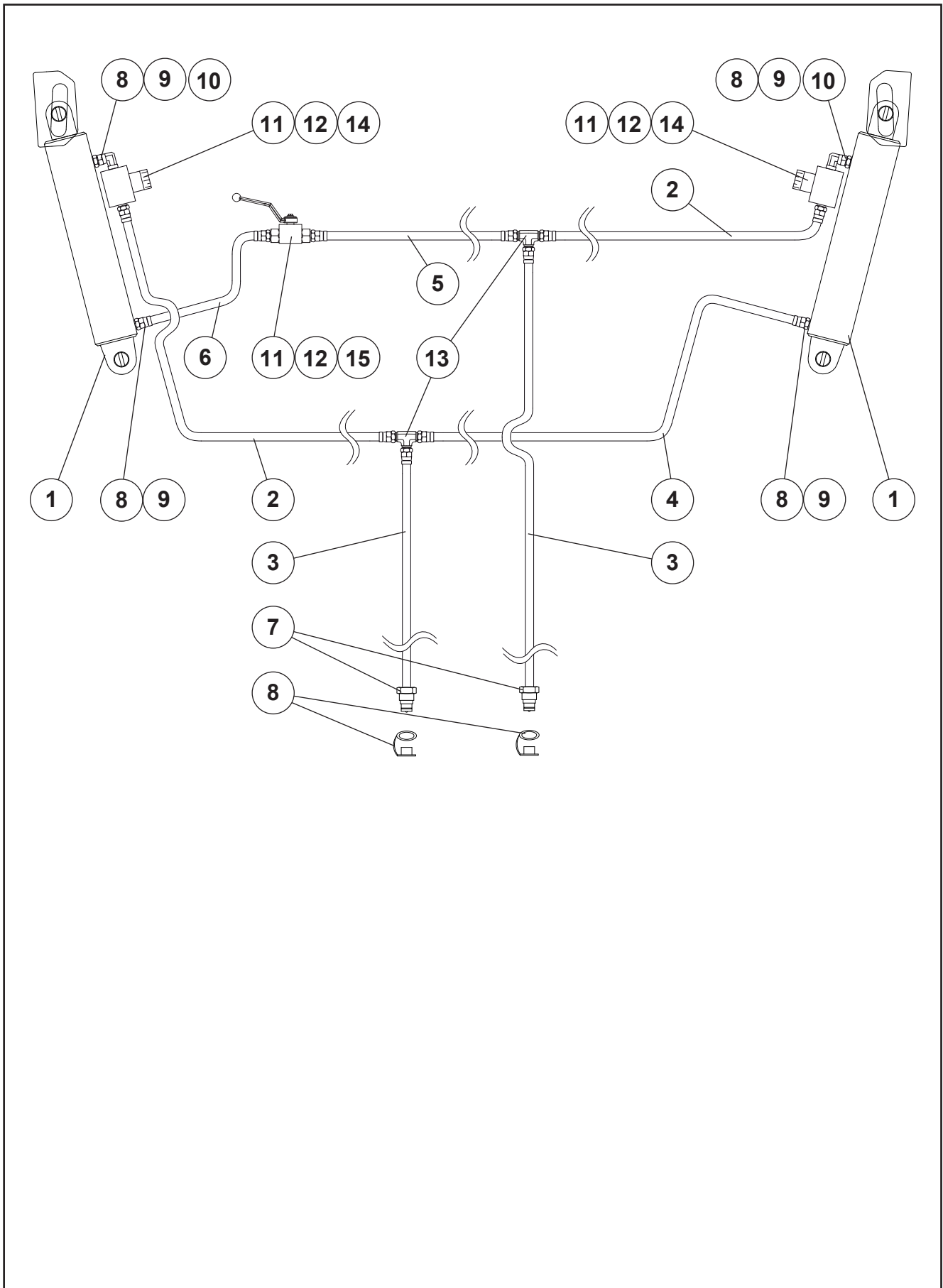

# ‘Renovator Classic Air’ Row Marker (Optional)

ITEM	PART No.	DESCRIPTION	QTY
KIT	61743K	Hydraulic hose & Fittings Kit:-	
1	61751	D/A RAM 2" x 1" x 8" Compact S (3/8" Ports)	2
2	61745	Hose 1.65m (Tee to Outer Cylinder via Needle Valve)	2
3	61744	Hose 3.80m (Tractor to Tee)	2
4	61746	Hose 1.60m (Tee to Inner Cylinder)	1
5	61747	Hose 1.15m (Tee to Ball Valve)	1
6	61748	Hose 0.70m (Ball Valve to Inner Cylinder)	1
7	43147	1/2" BSP Male Q.R. Coupling	2
8	44103	1/4" BSPM x 3/8" BSPPM Nipple	4
9	43391	3/8" Dowty Washer/Seal	4
10	44108	1/4" BSPPM x 1/4" BSPPF Swiv 90°	2
11	44104	1/4" BSPPM MM Nipple	4
12	44105	1/4" Dowty Washer/Seal	4
13	44106	1/4" BSP Tee MMM	2
14	44107	1/4" BSP Needle Valve	2
15	61749	1/4" Ball Valve with bracket mount	1
16	44962	M8 x 30 Grade 8.8 Z/P Bolt	2
17	45137	M8 Nyloc Nut	2
18	43617	1/2" Female Carrier Dust Plug	2