

The quick guide to installing and using the
Giltrap Fertiliser Spreader

*Models 2501, 3601, 5001, 6601 & 8301
with DICKEY-john Land Manager SE Controller*



Initial Setup

Component Layout

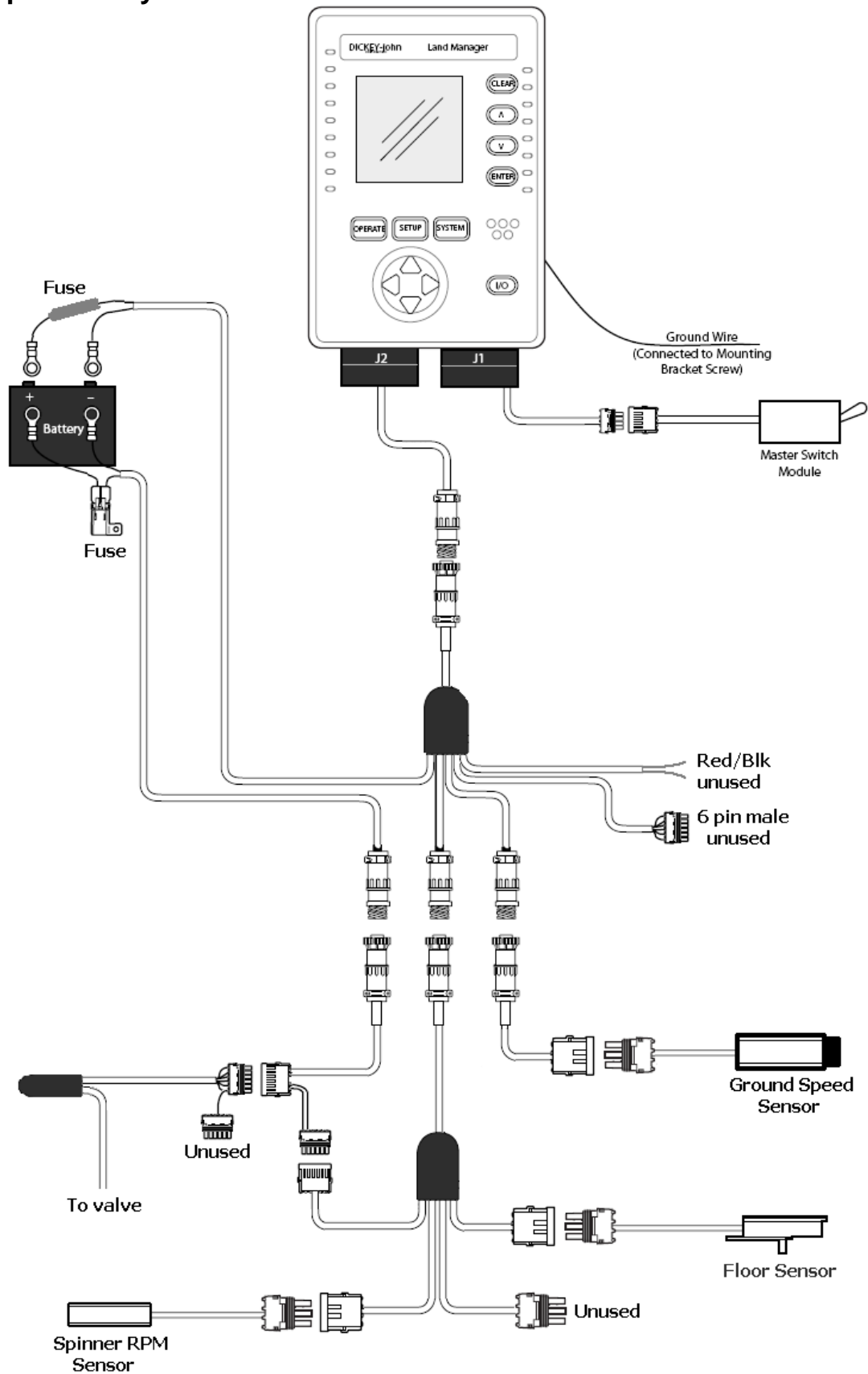

Power Supply

Two cables need to be connected together to a 12VDC power supply capable of supplying up to 2A.

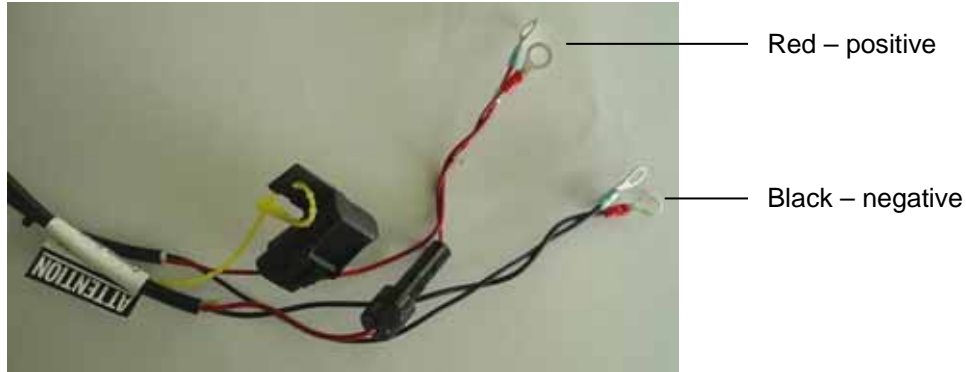

Installing the Controller

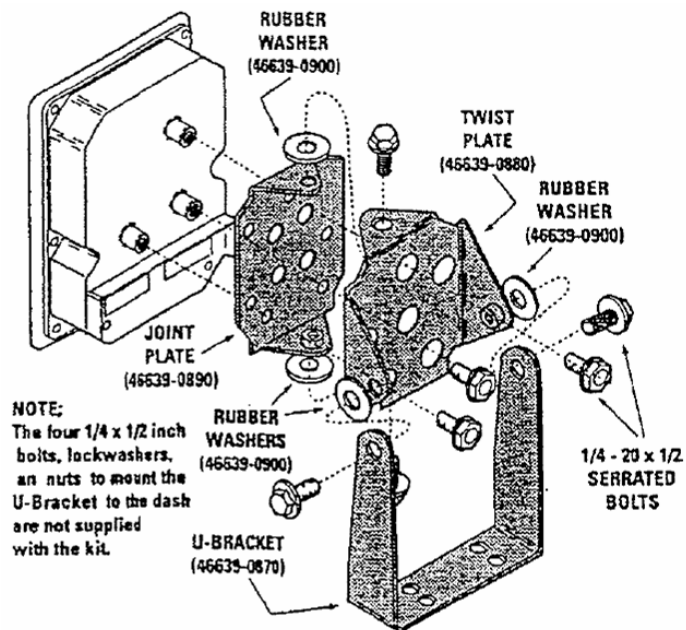

Select a suitable position for mounting the bracket assembly.
The braided ground wire (if supplied) should be screwed to the vehicle frame.

Hydraulic Requirements

The machine can be plugged into the quick release couplings of most tractors. It will require 60* litres per minute flow @ 2500 psi pressure.

* This flow rate is dependant on circuit type (parallel or series) and spinner motor size.

System Gain

This is required when a spreader is first setup on a tractor. It 'tunes' the computer to the tractors hydraulic flow.

Note:

- *Before running the Automatic Gain, ensure all the controlling parameters are correctly preset including decimal point being in the correct place. See page 9 for default settings and how to set them.*
- *It does not need product in the machine.*
- *The machine does not need to be moving.*

Press **SYSTEM** AUTOMATIC GAIN **ENTER**. You may need to enter a password (this is factory set to 664).

Do you need to limit the max channel output during cal? NO **ENTER**

Operate the tractor at normal operating revs before pressing **ENTER**. Material will be dispensed during calibration if the machine is loaded.

System Gain Failure

If the Automatic Gain fails during calibration, reduce the door height setting by one third. If it still fails, lower the default value by approx 0.02 (See page 10 for default settings and how to set #15) and retry.

Ground Speed Calibration

This is done by driving over a measured 100m straight distance.

It will have been factory preset and will only need to be redone if the wheels have been changed or there are operating inaccuracies.

Press **SYSTEM** and select GROUND SPEED **ENTER**.

Enter password (factory preset to 664) if required. Follow onscreen instructions and drive a pre-measured 100m at approx 5km/h without stopping. Repeat this twice to check accuracy.

Operating the Machine

Prior to operating the machine, read through and adjust the following settings;

Spinner Speed Adjustment

For most applications, adjust the spinners to 950 rpm using the spinner valve hand knob. Decrease the RPM for narrow width applications.

The RPM speed can be viewed on the controller by pressing the OPERATE button.

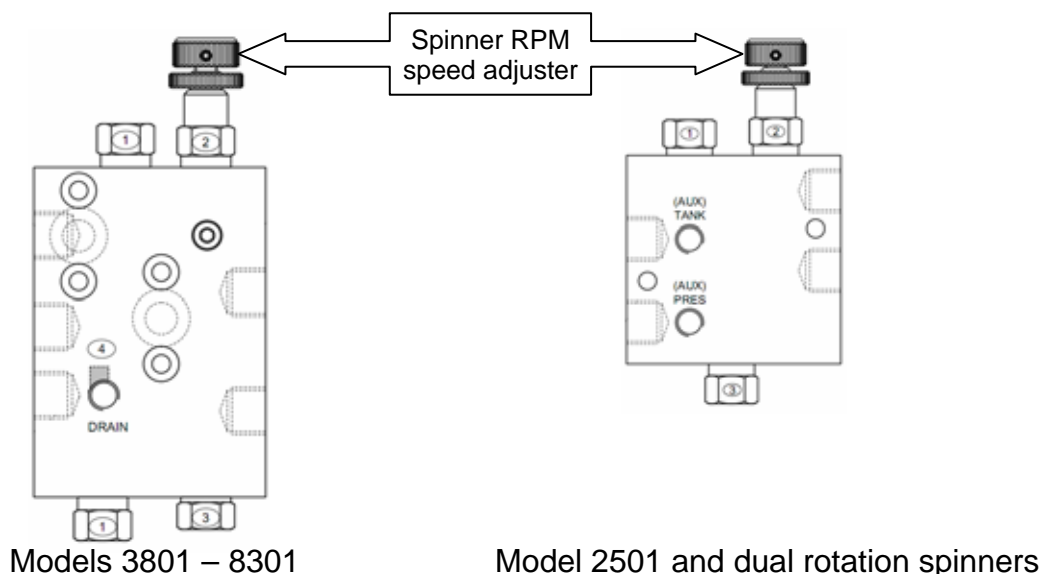

Setting Discharge Door Height

The 2501 model has 5 setting positions, and the 3801 – 8301 have 4 positions including fully closed.

Preset the opening to as per the table on page 12 and 13 depending on the product being spread.



Measure the door opening (from top of belt not cleats to bottom of door) and find the matching parameter in the table.

Note: If the application rate is very high and the controller displays the error message 'VALVE FULL OPEN', increase the opening size. Remember to also adjust the parameter to reflect this.

If the application rate is very fine, you may need to reduce the opening size and adjust the parameter to reflect this.

Reducing Hydraulic Oil Heat Buildup

To reduce heat on tractors with adjustable flow hydraulics, follow the method below.

1. Set the tractor hydraulic flow adjustment setting to maximum.
2. Adjust the tractor engine revs to normal operating speed.
3. Adjust the spinners to the correct speed.
4. Lower the hydraulic flow until the spinners begin to lose speed then increase slightly.

Note: The hydraulic flow may need to be increased if the machine is unable to discharge enough product for high application rates. (Discharge door is fully open and controller error reads 'VALVE FULL OPEN'.)

Fine Tuning the System Gain

The system gain may be fine tuned through the Channel Setup screen in SETUP Mode. Sometimes nonlinear components in the control channel causes oscillation or sluggishness at certain application rates. To fine tune, decrease the SYSTEM GAIN value slightly if the channel oscillates. Increase the SYSTEM GAIN value if the channel is sluggish.

Fine Tuning the Application Rate

If a small application rate error is consistently over or under, fine tuning the Constant number may be required. Typically, small errors result from overall spreader variations. Small consistent errors may be compensated for by adjusting the value of the spreader constant the same percentage as the error. For example, your application rate is set at 1000 kg per ha and over a period of time you discover you are actually spreading 1050 kg per ha (5% too high).

This means the spreader constant must be reduced by 5% or lowered to 95% of the original value. If the Spreader Constant is now 1000, the new value is calculated as follows;

$$\begin{aligned} \text{Present Spreader Constant} \times \text{Percent of original target} &= \\ \text{New Spreader Constant} & \\ \text{Therefore: a 5\% decrease is } 1000 \times .95 &= 950 \end{aligned}$$

If the product application is 5% under applied, the spreader constant requires raising from 100% to 105%. In this case, the number is calculated as follows:

$$\text{A 5\% increase is } 1000 \times 1.05 = 1050$$

Using the Land Manager SE controller

Controller Display

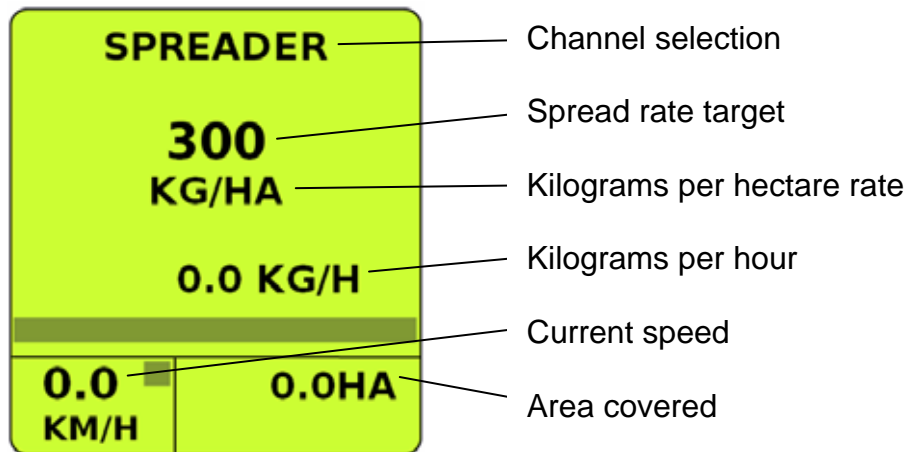

OPERATE BUTTON

There are four operating screens which are: SPREADER, ACCESSORY, ACCUMULATORS and ALARM HISTORY. Press the OPERATE button to rotate through the screens. Also press the OPERATE button to return to operation after making any setting changes.

SETUP BUTTON

Use the SETUP button to enter CHANNEL 1 SETUP. This is where spreading parameters are adjusted. The table on page 10 lists parameters.

SYSTEM BUTTON

Press the SYSTEM button to enter the SYSTEM MENU.

Master Switch Module

The Master Switch Module allows the user to start and stop product application through a single switch. The three switch positions include:

- Auto
- Off
- Manual (momentary position)

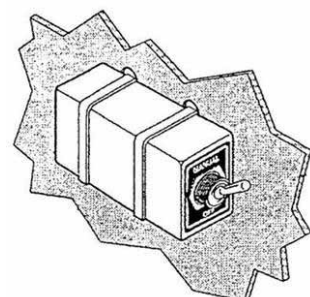



The typical operating position for field application is AUTO. In this position, ground speed controls the dispersal rate. When ground speed is reduced to zero, all application ceases. The OFF position of the switch inhibits all product flow. Generally, the MANUAL (momentary) position is for applications at very slow speeds (i.e., startup from rest). The ground speed startup value for the MANUAL position is programmable under the ground speed configuration.

The controller can be locked into MANUAL by holding the master switch in the MANUAL position and pressing the RIGHT arrow key. The MANUAL position forces the controller to use the manual ground speed, which minimizes system lags when starting up from slow speeds. To exit this condition and return to AUTO mode, the master switch must be turned OFF then back to AUTO.

Clearing Operating Statistics

Press OPERATE twice to enter ACCUMULATORS. Press CLEAR to clear SPREADER or SYSTEM depending which figure has been highlighted.

Channel Selection

Press OPERATE to get into the main operating screen
While in the main operating screen, press  to highlight SPREADER and press  button to toggle the channel on. The screen should now show the spreading rate. Then press the setup button.

Parameter Descriptions

1. APPLICATION RATE. Target rate for applying the product.
2. DENSITY. Relative density of the material being applied. It represents the weight of 1 litre of product.
3. INC/DEC STEP. The desired increment/decrement value to allow the operator to change the application rate by a specified amount during application (on-the-go) through the field.
4. MINIMUM RATE. Minimum acceptable product application rate the system allows.
5. MAXIMUM RATE. Maximum acceptable product application rate the system allows.
6. SPREADER CONSTANT. This value represents the pulse count produced by the sensor over a given distance (refer to GROUND SPEED CALIBRATION to calculate the constant).
7. MANUAL SPEED. This is an internally generated ground speed rate whenever the Master Switch module switch is held into the MANUAL position. This value may be set to any speed within the delivery capabilities of the system. This speed is also used when GROUND SPEED OVERRIDE is selected from the Manual Overrides screen.
8. MIN OVERRIDE. A minimum ground speed that automatically takes over system control between its set point and the SHUT OFF SPEED set point during slow down conditions.
9. SHUT OFF SPEED. The minimum ground speed allowed before the system ceases operation.
10. NUM OF SECTIONS. The total amount of boom sections used. Maximum of 6 sections.
11. 12V ON. YES indicates that 12V activates the solenoid. NO indicates that grounding activates the solenoid.
12. WIDTH SECTION 1. Spreading width (bout width).
13. DRAG BELT. Type of drag belt delivery system. Dual or Single belt/chain.
14. PRODUCT LEVEL. When ENABLED, the amount of product remaining is displayed on the PRODUCT LEVEL operate screen. The product level decreases as material is applied. When this is ENABLED the reset level and alarm level values are added to the SETUP menu structure and needs to be set.
15. SYSTEM GAIN. Affects the response of the control valve created by changes in ground speed. The larger the number the faster the response time. In field application, if the valve seems to be moving too rapidly and tends to be oscillating, this number should be lowered. The number may be as low as 1 or smaller but cannot be 0.0. If the valve seems to be moving too slowly, this value should be increased. The starting value is automatically set during Automatic Gain Calibration.

Parameter Defaults

Set the parameters as in the table below. These are only default setting and should be set to your requirements.

You should only need to adjust the parameters highlighted in bold in the table below.

Press SETUP to enter the parameters.

1.	APPLICATION RATE	<i>Set desired spread rate in kg per ha</i>
2.	DENSITY	<i>Set material density in kg per liter</i>
3.	INC/DEC STEP	<i>0.0 kg/ha</i>
4.	MINIMUM RATE	<i>0.0 kg/ha</i>
5.	MAXIMUM RATE	<i>15000 kg/ha</i>
6.	SPREADER CONST	<i>See Door Opening Table (page 12-13)</i>
7.	MANUAL SPEED	<i>15.0 km/h</i>
8.	MIN OVERRIDE	<i>0.0 km/h</i>
9.	SHUT OFF SPEED	<i>0.01 km/h</i>
10.	NUM OF SECTIONS	<i>1</i>
11.	12V ON	<i>NO</i>
12.	WIDTH SECTION 1	<i>Set driving width in metres</i>
13.	DRAG BELT	<i>SINGLE</i>
14.	PRODUCT LEVEL	<i>DISABLED</i>
15.	SYSTEM GAIN	<i>0.257</i>

Bulk Densities Guide

Please note these densities are a guide only and for accurate spreading each batch of product should be measured.

PRODUCT	kg / liter
CAN	1.1
DAP	1.1
Dolomite	1.4
Durasul Sulphur	1.35
Granmag	1.1
Lime	1.55
MAP	1.1
Meat and Bone Meal	0.8
Muriate of Potash	1.2
Nitrophoska 12-10-10	1.1
Nitrophoska Blue	1.1
Reactive Rock - Sechura	1.5
Salt	1.2
Serpentine Super	1.25
Sulphate of Ammonia	1.0
Sulphate of Potash	1.1
Sulphur (raw)	1.35
Superphosphate (granular)	1.2
Superphosphate (powder)	1.1
Triple Super	1.15
Urea	0.85

Door Opening Constants Table

Measure from the belt surface (not the ribs) to the bottom of the door.

3801-8301			2501 Mini	
Door opening (mm)	Constant		Door opening (mm)	Constant
13	65.15		13	78.92
14	60.50		14	73.29
15	56.47		15	68.40
16	52.94		16	64.13
17	49.82		17	60.35
18	47.06		18	57.00
19	44.58		19	54.00
20	42.35		20	51.30
21	40.33		21	48.86
22	38.50		22	46.64
23	36.83		23	44.61
24	35.29		24	42.75
25	33.88		25	41.04
26	32.58		26	39.46
27	31.37		27	38.00
28	30.25		28	36.64
29	29.21		29	35.38
30	28.23		30	34.20
31	27.32		31	33.10
32	26.47		32	32.06
33	25.67		33	31.09
34	24.91	34	30.18	
35	24.20	35	29.31	
36	23.53	36	28.50	
37	22.89	37	27.73	
38	22.29	38	27.00	
39	21.72	39	26.31	
40	21.18	40	25.65	
41	20.66	41	25.02	
42	20.17	42	24.43	
43	19.70	43	23.86	
44	19.25	44	23.32	
45	18.82	45	22.80	
46	18.41	46	22.30	
47	18.02	47	21.83	
48	17.65	48	21.38	
49	17.29	49	20.94	
50	16.94	50	20.52	
51	16.61	51	20.12	
52	16.29	52	19.73	
53	15.98	53	19.36	
54	15.69	54	19.00	
55	15.40	55	18.65	
56	15.13	56	18.32	
57	14.86	57	18.00	
58	14.60	58	17.69	
59	14.36	59	17.39	
60	14.12	60	17.10	
61	13.89	61	16.82	
62	13.66	62	16.55	

3801-8301		2501 Mini	
Door opening (mm)	Constant	Door opening (mm)	Constant
140	6.05	140	7.33
141	6.01	141	7.28
142	5.96	142	7.23
143	5.92	143	7.17
144	5.88	144	7.13
145	5.84	145	7.08
146	5.80	146	7.03
147	5.76	147	6.98
148	5.72	148	6.93
149	5.68	149	6.89
150	5.65	150	6.84
151	5.61	151	6.79
152	5.57	152	6.75
153	5.54	153	6.71
154	5.50	154	6.66
155	5.46	155	6.62
156	5.43	156	6.58
157	5.39	157	6.54
158	5.36	158	6.49
159	5.33	159	6.45
160	5.29	160	6.41

↑
LIME
↓

190	4.46	190	5.40
191	4.43	191	5.37
192	4.41	192	5.34
193	4.39	193	5.32
194	4.37	194	5.29
195	4.34	195	5.26
196	4.32	196	5.23
197	4.30	197	5.21
198	4.28	198	5.18
199	4.26	199	5.16
200	4.24	200	5.13
201	4.21	201	5.10
202	4.19	202	5.08
203	4.17	203	5.05
204	4.15	204	5.03
205	4.13	205	5.00
206	4.11	206	4.98
207	4.09	207	4.96
208	4.07	208	4.93
209	4.05	209	4.91
210	4.03	210	4.89

↑
COMPOST/
MULCH
↓

Note: Spinner rotation should be reversed for compost or mulch so it discharges out the rear rather than the side. This gives a better spread pattern.

Troubleshooting

SELF-TEST ERROR MESSAGES

All self-tests must successfully pass at start-up before the system becomes operational. A self-test failure appears on the display with an error message. Other types of errors show error messages as listed below.

Two types of self-test errors may occur during start-up. The more serious type causes the alarm to sound continually and cannot be cleared. The proper action for this type of error is to shut the system down and secure technical assistance.

A second type of error causing an alarm can be cleared. Operation may be able to continue but with unpredictable results. Try powering down and starting again. If the problem persists, secure technical assistance.

Error Messages

Displaying error messages makes problem isolation much easier for the operator. When one occurs, generally follow the instructions on the screen and continue operation.

Operational Errors (Correctable)

Correctable errors are caused by incorrect settings or a component on the applicator system has failed.

The following lists the error messages encountered with the cause of each.

Type 1 Error - 100 thru 199 series - System Critical

Shutdown all systems.

- Alarm 110 - CONTROL NOT RESPONDING CHANNEL
- Alarm 170 - MASTER SWITCH ERROR
- Alarm 181 - LOW VOLTAGE ALARM
- Alarm 182 - HIGH VOLTAGE ALARM

Type 2 Error - 200 thru 299 series - Error has occurred.

Corrective action should be taken by operator.

- Alarm 230 - VALVE IS FULL OPEN CHANNEL
- Alarm 240 - MAX SHAFT SPEED CHANNEL
- Alarm 250 - CHECK HYDRAULIC DRIVE CHANNEL
- Alarm 260 - MAX VALVE LIMIT CHANNEL
- Alarm 270 - MAX FLOW CAPACITY

Type 3 Error - 300 thru 399 series - Reminder.

- Alarm 340 - COMMUNICATIONS LOST WITH REMOTE CONTROL
- Alarm 360 - ACCESSORY: (Label for accessory) OUT OF RANGE ALARM
- Alarm 365 - ACCESSORY: (Label for accessory) LOGIC ALARM STATE

Type 4 Error - 400 - Alternate Function Active.

- Alarm 410 - MINIMUM GROUND SPEED OVERRIDE IS ACTIVE

Type 5 Error - 500 thru 599 series - System disabled.

- Alarm 500 - MASTER IN AUTO. TURN OFF
- Alarm 510 - SYSTEM TIMEOUT. CYCLE MASTER SWITCH

Type 6 Error - 600 thru 699 series - System failure.

Restart system to see if error failure clears. If it cannot be cleared after several attempts, record all the information on the screen and then call DICKEY-john Service for assistance.

- Alarm 635 - MEMORY READ ERROR
- Alarm 640 - MEMORY WRITE VERIFY ERROR
- Alarm 650 - UNEXPECTED INTERRUPT NUMBER
- Alarm 660 - WATCHDOG TIMEOUT BY TASK
- Alarm 670 - STACK OVER FLOW
- Alarm 680 - ALARM LOG CORRUPT
- Alarm 690 - VIDEO MEMORY ERROR

Troubleshooting Tips

Clearing Minor Problems

Until you become familiar with the basic functions of Land Manager® SE, small problems may arise. If a problem does occur, follow the approach outlined below:

- Carefully define the problem.
- Make sure you have not overlooked something simple.
- Scan through the list below to find the problem or something similar.

If the problem can not be resolved, call for assistance and have the following information available.

1. System Configuration and constants.
2. List of errors logged in the Alarm History.
3. Model number (Located on decal on rear of console)
4. List of events leading up to the problem.

Console won't turn on.

- Bad fuse or no battery voltage. Check the fuses first and then the battery voltage to the Display Console.
- Battery terminal corrosion can result in poor battery connection. Clean the battery connections.

Alarm sounds but display is dark.

- Try adjusting the contrast on the display.

Alarm sounds continuously but does not sound normal.

- Vehicle battery voltage is low (Below 10V).

Application continues even after power is turned off.

- Display Console has lost communications with the system control devices. Problem could be a broken wire or even a bad actuator valve. Manually shut everything down and check all connections. The problem may be in the cabling or electronics – suspect faulty cabling or a bad sensor/actuator.

Alarm sounds (Beeps).

- Normal alarm condition for application error (Valve wide open). Reduce ground speed. If it persists, check valve for missing or faulty components.
- Master Switch Module is in the AUTO or MANUAL position and control valve is wide open. Check the feedback sensor or reduce speed.
- The Master Switch Module was left in the AUTO position after the vehicle has come to a stop and the shutdown time has elapsed. Turn the master switch off.

Alarm sounds and the display indicates an application error while driving through the field.

- Console doesn't see the correct application rate for the speed you are driving. Lower the driving speed; check the application rate entered into the Setup mode.

System won't run in AUTO.

- Vehicle must be moving for the system to run in AUTO. Check to see if Land Manager® SE operates in Manual.
- Check for adequate hydraulic oil flow.
- Check for a blown fuse to the actuator power input.

Alarm beeps and display indicates an application error.

- Control valve may be wide open.
- Blockage is caused by something other than the system or control valve.
- Manual or electric valves closed.

Ground speed is incorrect.

- No or very low ground speed appears on the display. Check for either an incorrect constant or a faulty ground speed sensor. Check sensor is positioned correctly.